

RMS20

MANUAL SETTING TYPE MAGNETIC ENCODERS

FEATURES

- High resolution of 256 P/R and fine setting
- Lower consumption of electric power (15 mA maximum) due to magnetic method
- Long life for 10⁵ times continuous run due to contactless & magnetic method
- Square wave output (with Amp.)
- Smooth rotation for setting

RoHS compliant



PART NUMBER DESIGNATION

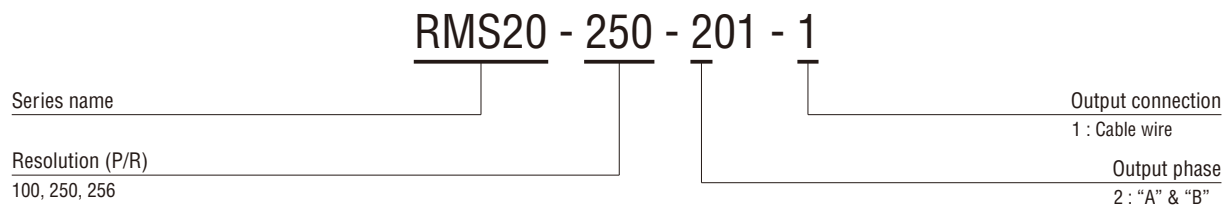

LIST OF PART NUMBERS

Resolution	Item	Input voltage	Part number
100 (P/R)		5 V	RMS20-100-201-1
250 (P/R)			RMS20-250-201-1
256 (P/R)			RMS20-256-201-1

※ : Verify the above part numbers when placing orders.

STANDARD SPECIFICATIONS

Electrical characteristics

Input voltage	DC5 V ± 5 %		
Input current	15 mA maximum (No load)		
Output wave form	Square wave		
Output phases	A, B		
Resolution (P/R)	100	250	256
Phase difference of outputs A & B	90° ± 45°		
Maximum frequency response	5 kHz		
Output signal	"1 (High)"	+ 4.5 V minimum	
	"0 (Low)"	+ 0.5 V maximum	
Sensor	Magnetoresistive element		

Mechanical characteristics

Rotational torque	4.90 mN·m (50 gf·cm) maximum	
Inertia	3 g·cm ² maximum	
Shaft loading (When mounting)	Radial	9.81 N (1 kgf) maximum
	Axial	9.81 N (1 kgf) maximum
Rotational life	10 ⁵ revolution	
Net weight	Approx. 20 g	
Strength of tighten screw	0.49 N·m (5 kgf·cm) maximum	

Environmental characteristics

Operating temp. range	- 10 ~ 60 °C
Storage temp. range	- 40 ~ 70 °C

OUTPUT

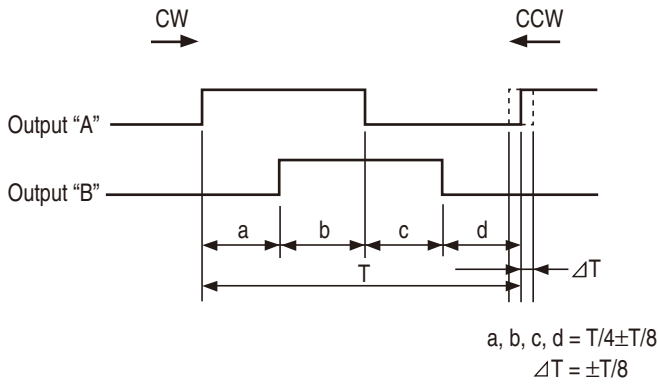

ELECTRICAL WIRING

Red	Power ⊕
Brown	Output "B"
White	Output "A"
Black	Power 0 (V)

OUTPUT CIRCUIT

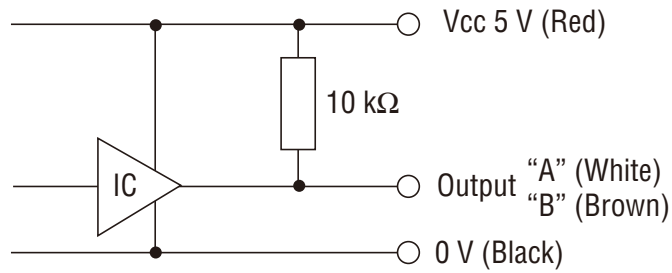

Sink current 1 mA maximum (at 25 °C)