

AVX

A KYOCERA GROUP COMPANY

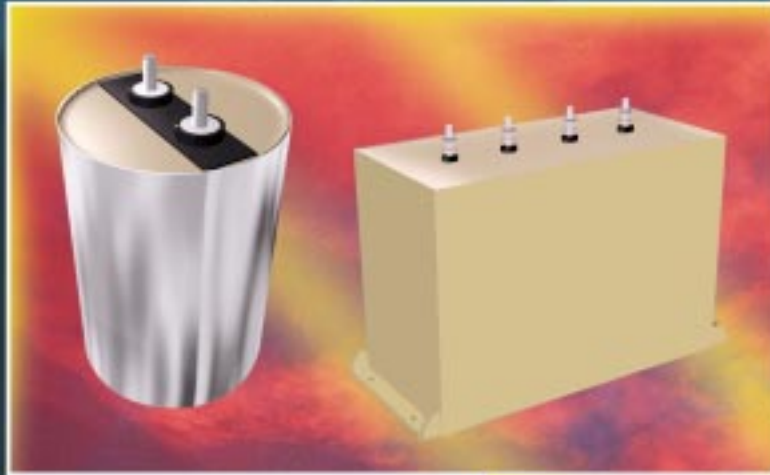

TPC Capacitors For Power Electronics Medium Power Capacitors

MEDIUM POWER FILM CAPACITORS

DC FILTERING

FFB	4-9
FFV3	10-12
FFVE/FFVI	13-15
FFLI/FFLT	16-17
FFLC/FFLP	18-19
FSG	20-21
FSM	22-23

DC PROTECTION

FSB	24-26
FPX	27-30
FPG	31-34

TUNING

FAV	35-36
FAI	37-44

In 1979, TPC (formerly LCC, then THOMSON-CSF PASSIVE COMPONENTS) developed the **CONTROLLED SELF-HEALING technology** for medium power capacitors.

In 1988, TPC further evolved the **CONTROLLED SELF-HEALING technology** for use in impregnated and non-impregnated DC filtering capacitor (**TFM or TRAFIM, IFM, FFL, FFV and other** series).

These capacitors made great advances over previous technologies by combining the benefits of the Controlled Self-Healing process and superior energy densities, making it one of the most compact capacitors on the market for 1/2 CV².

TPC produces both dry-wound and impregnated capacitors for medium voltage filtering, covering the whole spectrum from 75Vdc to 3kVdc.

With CONTROLLED SELF-HEALING, the capacitance is divided into several million elementary capacitor elements protected by “fuse gates”. Weak points of the dielectric are insulated and the capacitor continues functioning normally without any short circuit or explosion.

The capacitor acts like a battery. It “consumes” a certain amount of the capacitance through the gradual breakdown of the individual capacitance cells. Over the operating life of the capacitor, the capacitance gradually decreases. At the end of the capacitor’s life, the nominal capacitance will decrease down to either 2%, 5% or can be determined per customer requirements.

NOTICE: Specifications are subject to change without notice. Contact your nearest AVX Sales Office for the latest specifications. All statements, information and data given herein are believed to be accurate and reliable, but are presented without guarantee, warranty, or responsibility of any kind, expressed or implied. Statements or suggestions concerning possible use of our products are made without representation or warranty that any such use is free of patent infringement and are not recommendations to infringe any patent. The user should not assume that all safety measures are indicated or that other measures may not be required. Specifications are typical and may not apply to all applications.

Medium Power Film Capacitors



General Description

DC FILTERING

DC FILTERING

The series uses a dry-wound (non-oil-filled) segmented metallized polypropylene or polyester dielectric, which features the controlled self-healing process, specially treated to have a very high dielectric strength in operating conditions up to 85°C, and up to 100°C for the FFB series.

For more information on how segmented metallized films and controlled self-healing works see a complete presentation.

AN ALTERNATIVE TO ELECTROLYTICS

FF series capacitors can be a very interesting alternative to electrolytic capacitors, because they can withstand much higher levels of surge voltage, very high rms currents and offer longer lifetimes (see section on lifetime as well as determination tables).

APPLICATIONS

The FF series capacitors are specifically designed for DC filtering and low reactive power. Main applications are: power supplies, motors, drives, electric utilities, induction heating, people movers, tramways, metro systems, unit supported power supplies, etc.

STANDARDS

- IEC 1071-1, IEC 1071-2: Power electronic capacitors
- IEC 384-1: PET Electronic Capacitor
- IEC 68-1: Environmental testing
- IEC 77: Rules for electric traction equipment
- UL 94: Fire requirements
- NF F 16-101
- NF F 16-102: Fire and smoke requirements

WORKING TEMPERATURE

-40°C to +85°C (up to +100°C for FFB series)

LIFETIME EXPECTANCY

One unique feature of the segmented metallized technology is how the capacitor acts at the end of its lifetime. While electrolytic capacitors present a strong risk of short-circuit and consequently explosion, this film capacitor simply experiences a loss of capacitance of about 5%, with no risk of explosion. The capacitor gradually loses capacitance over its lifetime (like a battery), and eventually becomes an open circuit.

Lifetime, therefore, as it is defined here, is a function of several elements:

- Decrease in capacitance limit (-5% in the example above)
- Average applied voltage (expressed as a ratio vs nominal rated voltage)
- Average hot spot temperature

By changing any of these parameters we can change the defined "lifetime" of the capacitor. This lifetime is theoretical, however as the capacitor continues to function even beyond the preestablished limit on capacitance decrease. See lifetime expectancy tables as part of this catalog to help in this determination.

General Description

CAPACITANCE FOR POLYESTER DIELECTRIC

Capacitance of polyester capacitors is a function of temperature and frequency (see the curves).

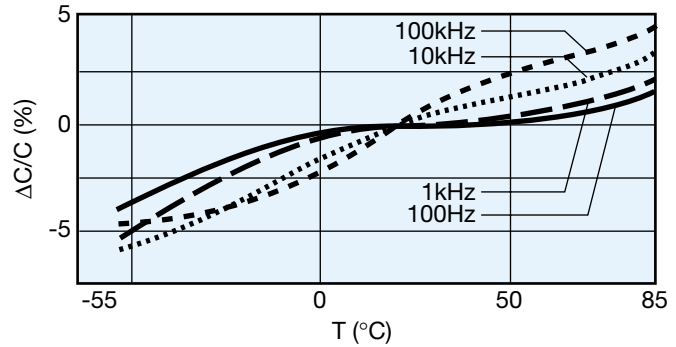
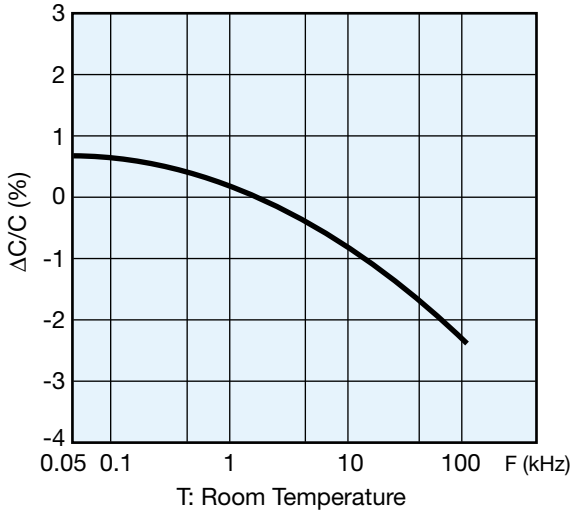

TANGENT OF LOSS ANGLE (TANδ₀) FOR POLYESTER DIELECTRIC

Dielectric loss factor of polyester is a function of temperature and frequency (see the curves).

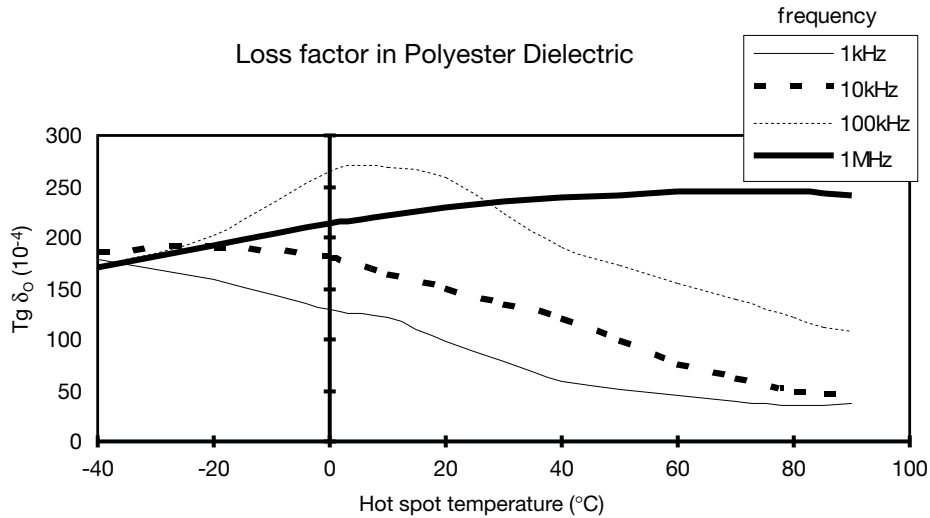

TANGENT OF LOSS ANGLE (TANδ₀) FOR POLYPROPYLENE DIELECTRIC

Polypropylene has a constant dielectric loss factor of 2×10^{-4} irrespective of temperature and frequency (up to 1 MHz).

HOT SPOT CALCULATION

Calculate the maximum operating (hot spot) temperature in the following manner:

The loss factor of the capacitor is made up of the sum of two components. The first represents electrical losses (see the curve polyester losses) and the second represents Joule effect in the connections and foil. For detail formulas refer to industrial products.

Medium Power Film Capacitors



FFB

DC FILTERING

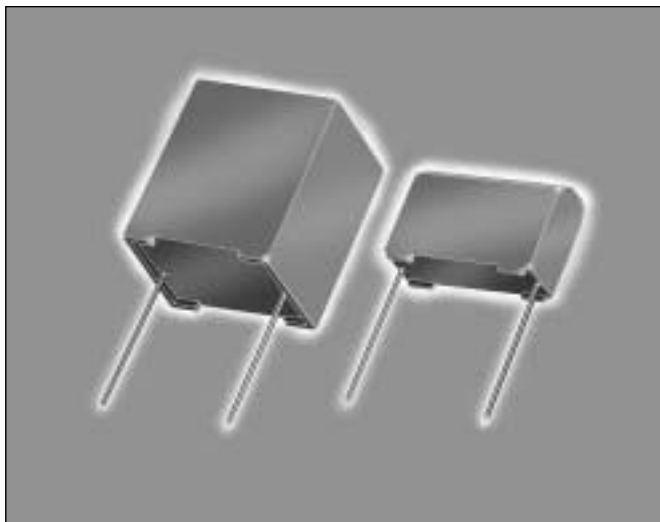

The FFB series uses a non-impregnated metallized polypropylene or polyester dielectric with the controlled self-healing process, specially treated to have a very high dielectric strength in operating conditions up to 100°C.

The FFB has been designed for printed circuit board mounting. Furthermore, their performances allow to be a very interesting alternative to electrolytic technology because they can withstand much higher levels of surge voltage.

APPLICATIONS

The FFB capacitor is particularly designed for DC filtering, low reactive power.

GENERAL CHARACTERISTICS

Climatic category 55/100/56 (IEC 68)

Test voltage between terminals @ 25°C
 $1.5 \times V_{n,dc}$

STANDARDS

- IEC 1071-1, IEC 1071-2: Power electronic capacitors
- IEC 60 384-16: Fixed metallized polypropylene film dielectric DC capacitors
- IEC 60 384-16-1: Fixed metallized polypropylene film dielectric DC capacitors Assessment level E
- IEC 60 384-17: Fixed metallized polypropylene film dielectric AC and pulse capacitors
- IEC 60 384-17-1: Fixed metallized polypropylene film dielectric AC and pulse capacitors Assessment level E

WORKING TEMPERATURE

(according to the power to be dissipated) -55°C to +100°C

LIFETIME EXPECTANCY

One unique feature of this technology (as opposed to electrolytics) is how the capacitor reacts at the end of its lifetime. Whereas, with an electrolytic, there is a strong risk of explosion of the case. However, with our line of film capacitors, the capacitor will simply experience at the end of life a loss of capacitance of about 5%, with no risk of explosion.

Please note that this is theoretical, however, as the capacitor continues to be functional even after this 5% decrease.

HOT SPOT TEMPERATURE CALCULATION

You can calculate the maximum operating (hot spot) temperature of this capacitor in the following manner:

The loss factor of the capacitor is made up of the sum of two components. The first represents electrical losses in the dielectric and the second component represents Joule effect in the connection and foils ($R_s \cdot C \cdot 2 \pi f$).

For all applications, the temperature in the hot spot capacitor must be lower than 100°C.

$$\theta_{\text{hot spot}} = \theta_{\text{ambient}} + [\text{tg} \delta_0 \cdot Q + R_s \cdot (I_{\text{rms}})^2] \cdot R_{\text{th}}$$

With:

Q : Reactive power in Var

R_s in Ohm

I_{rms} in Ampere

R_{th} : Rth ambient / hot spot in °C/W

$\text{tg} \delta_0 \cdot (10^{-4})$ is the tangent of loss angle (see $\tan \delta_0$ page 3)

PACKAGING

Self-extinguishing plastic case (V0 = in accordance with UL 94) filled thermosetting resin.

Self-extinguishing thermosetting resin (V0 = in accordance with UL 94; M2F1 = in accordance with NF F 16-101).

Medium Power Film Capacitors



FFB

GENERAL DESCRIPTION

DC FILTERING

BOX KIND: P0; 18; 19; 26; R68

2 TERMINALS SOLUTION

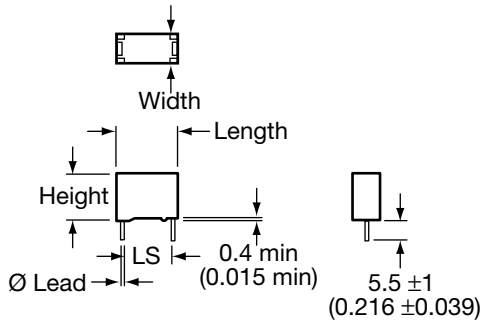

General Tolerance: $\pm 0.5\text{mm}$ (0.020)

BOX KIND: R68

4 TERMINALS SOLUTION

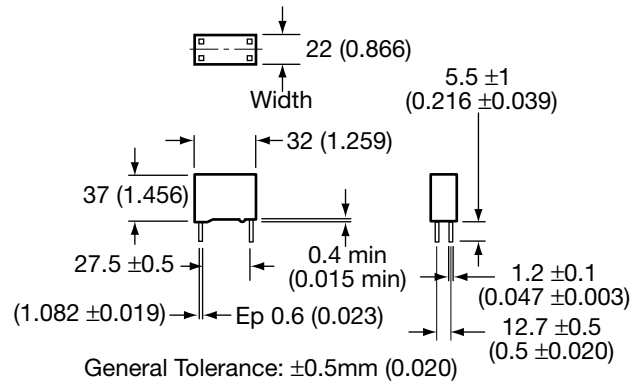

General Tolerance: $\pm 0.5\text{mm}$ (0.020)

DIMENSIONS: millimeters (inches)

Box Kind	Length mm ± 0.40 (inches)	Width mm ± 0.40 (inches)	Height mm ± 0.30 (inches)	Dimensions lead mm (inches)	LS mm ± 0.40 (inches)
P0	31.1 (1.230)	13.0 (0.051)	22.4 (0.880)	\varnothing 0.80 (0.031)	27.5 (1.083)
18	31.1 (1.230)	14.6 (0.580)	25.7 (1.010)	\varnothing 0.80 (0.031)	27.5 (1.083)
19	31.1 (1.230)	17.3 (0.068)	29.8 (1.170)	\varnothing 0.80 (0.031)	27.5 (1.083)
26	31.1 (1.230)	20.8 (0.820)	31.3 (1.230)	\varnothing 1.00 (0.039)	27.5 (1.083)
R68 2 Terminals Solution	32.0 (1.260)	22.0 (0.870)	37.0 (1.460)	\varnothing 1.00 (0.039)	27.5 (1.083)
R68 4 Terminals Solution	32.0 (1.260)	22.0 (0.870)	37.0 (1.460)	1.20 x 0.60 (0.047 x 0.023)	27.5 (1.083)

DC FILTERING FOR LOW VOLTAGE

ELECTRICAL CHARACTERISTICS

Capacitance range C_n	6.2 μ F to 110 μ F
Tolerance on C_n	$\pm 10\%$
Rated DC voltage $V_{n,dc}$	75 to 400 V
Dielectric	polyester

HOT SPOT CALCULATION

$$\theta_{\text{hot spot}} = \theta_{\text{ambient}} + (P_d + P_t) \times R_{th}$$

with P_d (Dielectric losses) = $Q \times \text{tg}\delta_0$
 $Q \times \text{tg}\delta_0 \Rightarrow [\frac{1}{2} \times C_n \times (V_{\text{peak to peak}})^2 \times f] \times \text{tg}\delta_0$
(see $\text{tg}\delta_0$ for polyester dielectric page 3)

$$P_t \text{ (Thermal losses)} = R_s \times (I_{rms})^2$$

where C_n in Farad I_{rms} in Ampere f in Hertz
 V in Volt R_s in Ohm θ in $^{\circ}\text{C}$
 R_{th} in $^{\circ}\text{C/W}$

Medium Power Film Capacitors



FFB

DC FILTERING FOR LOW VOLTAGE

POLYESTER DIELECTRIC

TABLE OF VALUES

Capacitance (μF)	Box Kind	I _{rms} max. (A)	R _s (mΩ)	R _{th} (°C/W)	Part Number
V_{ndc} 75V Vrms max.: 45 volts					
33	PO	3	3	40.7	FFB14D0336K--
47	18	4.3	2	33.3	FFB24D0476K--
68	19	6.2	1.7	29.9	FFB34D0686K--
82	26	7.4	1.6	26.7	FFB44D0826K--
110	R68 (2 terminals)	10	1.4	22.9	FFB54D0117K--
110	R68 (4 terminals)	10	1.4	22.9	FFB54D0117KJC
V_{ndc} 100V Vrms max.: 60 volts					
20	PO	2.6	3	40.5	FFB14E0206K--
27	18	3.5	2.5	33.3	FFB24E0276K--
39	19	5	2	29.8	FFB34E0396K--
47	26	6	1.7	26.6	FFB44E0476K--
68	R68 (2 terminals)	9	1.4	22.8	FFB54E0686K--
68	R68 (4 terminals)	9	1.4	22.8	FFB54E0686KJC
V_{ndc} 300V Vrms max.: 90 volts					
7.5	PO	2.4	16	40.7	FFB14H0755K--
11	18	3.6	11	33.5	FFB24H0116K--
16	19	5.2	8	29.9	FFB34H0166K--
18	26	6	7	27.1	FFB44H0186K--
27	R68 (2 terminals)	9	5	22.9	FFB54H0276K--
27	R68 (4 terminals)	9	5	22.9	FFB54H0276KJC
V_{ndc} 400V Vrms max.: 105 volts					
6.2	PO	2.5	17	40.5	FFB14I0625K--
7.5	18	3.1	14	33.5	FFB24I0755K--
12	19	5	9	29.9	FFB34I0126K--
15	26	6.2	7	26.4	FFB44I0156K--
20	R68 (2 terminals)	8.2	5.5	22.8	FFB54I0206K--
20	R68 (4 terminals)	8.2	5.5	22.8	FFB54I0206KJC

DC FILTERING

LIFETIME EXPECTANCY vs V_w/V_n AND HOT SPOT TEMPERATURE

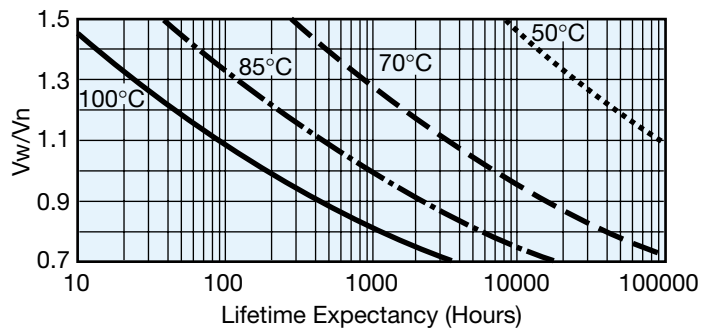

V_w = Working DC Voltage

V_n = Rated DC Voltage

DC FILTERING FOR INDUSTRIAL APPLICATION

These capacitors have been designed principally for high and medium power DC filtering applications.

ELECTRICAL CHARACTERISTICS

Capacitance range C_n	1.5 μ F to 13 μ F
Tolerance on C_n	$\pm 10\%$
Rated DC voltage $V_{n,dc}$	525 to 1100 V
Dielectric	polypropylene

TANGENT OF LOSS ANGLE ($TAN\delta_0$) FOR POLYPROPYLENE DIELECTRIC

Polypropylene has a constant dielectric loss factor of 2×10^{-4} irrespective of temperature and frequency (up to 1 MHz).

HOT SPOT TEMPERATURE CALCULATION

You can calculate the maximum operating (hot spot) temperature of this capacitor in the following manner:

The loss factor of the capacitor is made up of the sum of two components. The first represents electrical losses ($tg \delta_0 = 2 \times 10^{-4}$) and the second component represents Joule effect in the connection and foils, ($R_s.C.2 \pi f$).

For all applications, the temperature in the hot spot capacitor must be lower than 100°C. Heating calculation of hot spot capacitor:

$$\theta_{hot\ spot} = \theta_{ambient} + [tg\delta_0 \cdot Q + R_s \cdot (I_{rms})^2] \cdot R_{th}$$

With:

Q : Reactive power in Var

R_s in Ohm

I_{rms} in Ampere

R_{th} : Rth ambient / hot spot in °C/W

$tg \delta_0 \cdot (10^{-4})$ is the tangent of loss angle for polypropylene dielectric. Polypropylene has a constant dielectric losses factor of 2×10^{-4} irrespective of temperature and frequency (up to 1 MHz).

Medium Power Film Capacitors



FFB

DC FILTERING FOR INDUSTRIAL APPLICATION

POLYPROPYLENE DIELECTRIC

TABLE OF VALUES

Capacitance (μF)	Box Kind	I _{rms} max. (A)	R _s (mΩ)	R _h (°C/W)	Part Number
V_ndc 525V Vrms max.: 105 volts					
3.9	PO	5.1	30	45.7	FFB16J0395K--
5.6	18	7.4	21	36.4	FFB26J0565K--
8.2	19	10.9	15	32.6	FFB36J0825K--
10	26	13.3	12	29.8	FFB46J0106K--
13	R68 (2 terminals)	16.7	9	24.3	FFB56J0136K--
13	R68 (4 terminals)	16.7	9	24.3	FFB56J0136KJC
V_ndc 720V Vrms max.: 120 volts					
3.3	PO	5.0	31	45.0	FFB16A0335K--
4.3	18	6.5	24	36.2	FFB26A0435K--
6.2	19	9.4	17	32.7	FFB36A0625K--
7.5	26	11.4	14	29.9	FFB46A0755K--
10	R68 (2 terminals)	15.2	11	24.2	FFB56A0106K--
10	R68 (4 terminals)	15.2	11	24.2	FFB56A0106KJC
V_ndc 900V Vrms max.: 150 volts					
2	PO	3.6	41	45.7	FFB16C0205K--
2.7	18	4.9	30	36.6	FFB26C0275K--
3.9	19	7.2	21	32.9	FFB36C0395K--
5.1	26	9.3	16	29.7	FFB46C0515K--
6.8	R68 (2 terminals)	12.5	12	24.1	FFB56C0685K--
6.8	R68 (4 terminals)	12.5	12	24.1	FFB56C0685KJC
V_ndc 1100V Vrms max.: 180 volts					
1.5	PO	3.3	45	45.2	FFB16L0155K--
1.8	18	3.9	40	36.5	FFB26L0185K--
2.4	19	5.3	28	33.4	FFB36L0245K--
3	26	6.6	23	30.2	FFB46L0305K--
4.7	R68 (2 terminals)	10.3	15	24.1	FFB56L0475K--
4.7	R68 (4 terminals)	10.3	15	24.1	FFB56L0475KJC

DC FILTERING

LIFETIME EXPECTANCY vs V_w/V_n AND HOT SPOT TEMPERATURE

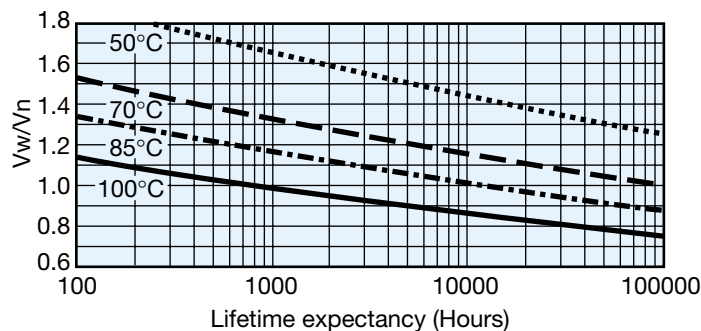

V_w = Working DC Voltage

V_n = Rated DC Voltage

Medium Power Film Capacitors



FFV3 General Description

DC FILTERING

DC FILTERING

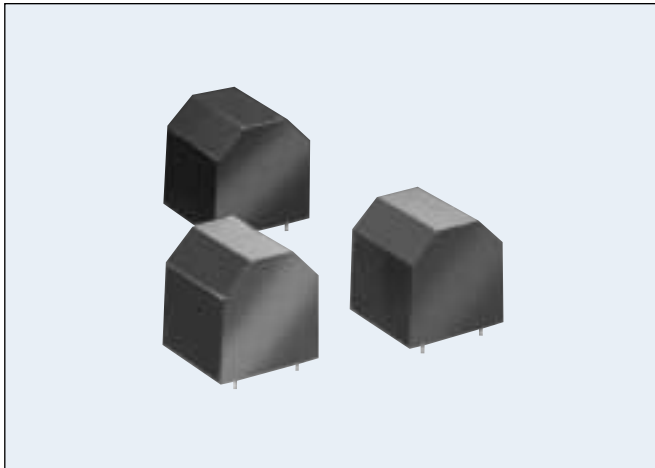

The series uses a non-impregnated metallized polypropylene or polyester dielectric, with the controlled self-healing process, specially treated to have a very high dielectric strength in operating conditions up to 85°C.

The FFV3 has been designed for printed circuit board mounting.

APPLICATIONS

The FFV3 capacitors are particularly designed for DC filtering, low reactive power.

PACKAGING

Self-extinguishing plastic case (V0 = in accordance with UL 94) filled thermosetting resin.

Self-extinguishing thermosetting resin (V0 = in accordance with UL 94; M2F1 = in accordance with NF F 16-101).

LIFETIME EXPECTANCY

One unique feature of this technology (as opposed to electrolytics) is how the capacitor reacts at the end of its lifetime. Whereas, with an electrolytic, there is a strong risk of explosion of the case. However, with our line of film capacitors, the capacitor will simply experience at the end of life a loss of capacitance of about 5%, with no risk of explosion.

Please note that this is theoretical, however, as the capacitor continues to be functional even after this 5% decrease.

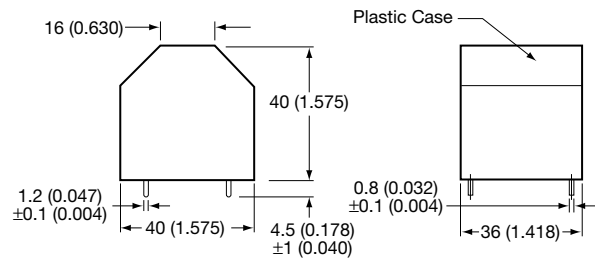
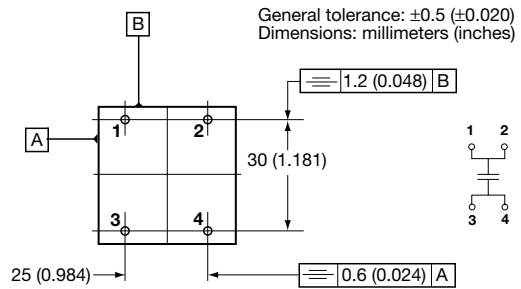

STANDARDS

- IEC 1071-1, IEC 1071-2: Power electronic capacitors
- IEC 60 384-16: Fixed metallized polypropylene film dielectric DC capacitors
- IEC 60 384-16-1: Fixed metallized polypropylene film dielectric DC capacitors Assessment level E
- IEC 60 384-17: Fixed metallized polypropylene film dielectric AC and pulse capacitors
- IEC 60 384-17-1: Fixed metallized polypropylene film dielectric AC and pulse capacitors Assessment level E
- IEC 384-2: Fixed metallized polyester capacitors

GENERAL CHARACTERISTICS

Climatic category	40/85/56 (IEC 68)
Test voltage between terminals @ 25°C	1.5 x $V_{r,dc}$ during 10s
Test voltage between terminals and case @ 25°C	@ 4 kVrms @ 50 Hz during 1 min.

Medium Power Film Capacitors



FFV3 for Low Voltage Applications

DC FILTERING

POLYESTER DIELECTRIC

ELECTRICAL CHARACTERISTICS

Capacitance range C_n	30 μ F to 160 μ F
Tolerance on C_n	$\pm 10\%$
Rated DC voltage V_{ndc}	75 to 400 V
Dielectric	polyester

Capacitance (μ F)	$I_{rms\ max.}$ (A)	$(I^2t)_{10\ shots}$ (A^2s)	$(I^2t)_{1000\ shots}$ (A^2s)	R_s (m Ω)	R_{th} ($^{\circ}C/W$)	Part Number
$V_{ndc} = 75\ V$ $V_{rms} = 45\ v\ max$						
130	23	370	37	0.56	5.60	FFV34D0137K--
160	28	560	56	0.47	5.00	FFV34D0167K--
$V_{ndc} = 100\ V$ $V_{rms} = 60\ v\ max$						
80	19	250	25	0.67	6.16	FFV34E0806K--
100	24	390	39	0.55	5.42	FFV34E0107K--
$V_{ndc} = 160\ V$ $V_{rms} = 75\ v\ max$						
55	17	180	18	0.77	6.56	FFV34F0556K--
65	20	260	26	0.66	5.97	FFV34F0656K--
$V_{ndc} = 300\ V$ $V_{rms} = 90\ v\ max$						
40	20	150	15	2.80	9.58	FFV34H0406K--
50	26	230	23	2.25	8.46	FFV34H0506K--
$V_{ndc} = 400\ V$ $V_{rms} = 105\ v\ max$						
30	17	110	11	2.93	9.92	FFV34I0306K--
40	23	200	20	2.21	8.41	FFV34I0406K--

LIFETIME EXPECTANCY

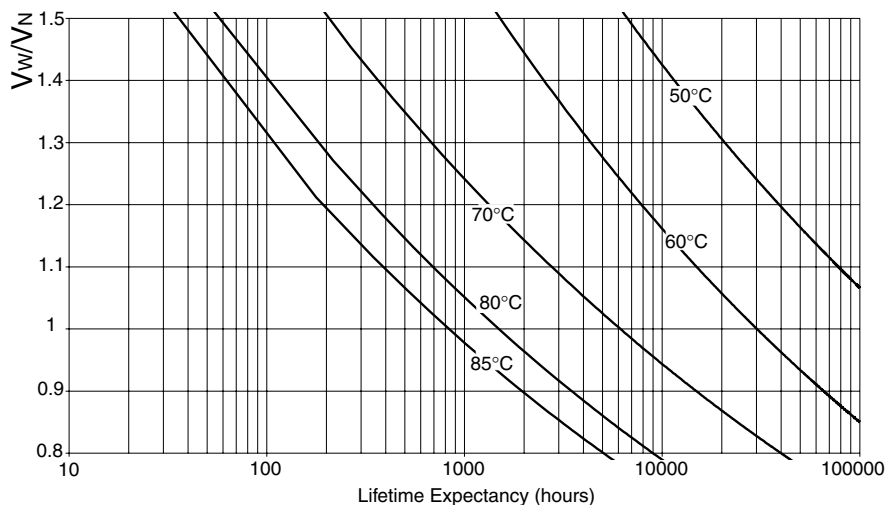

HOT SPOT CALCULATION

$$\theta_{hot\ spot} = \theta_{ambient} + (P_d + P_t) \times (R_{th} + 7.4)$$

$$\theta_{hot\ spot} = \theta_{case} + (P_d + P_t) \times R_{th}$$

with P_d (Dielectric losses) = $Q \times tg\delta_0$
 $\Rightarrow [\frac{1}{2} \times C_n \times (V_{peak\ to\ peak})^2 \times f] \times tg\delta_0$
 (see $tg\delta_0$ curves page 3)

$$P_t \text{ (Thermal losses)} = R_s \times (I_{rms})^2$$

where C_n in Farad I_{rms} in Ampere f in Hertz
 V in Volt R_s in Ohm θ in $^{\circ}C$
 R_{th} in $^{\circ}C/W$ R_{th} : R_{th} case/hot spot in $^{\circ}C/W$



Medium Power Film Capacitors



FFV3 DC for Medium and High Voltage Applications

DC FILTERING

POLYPROPYLENE DIELECTRIC

ELECTRICAL CHARACTERISTICS

Capacitance range C_n	6 μ F to 25 μ F
Tolerance on C_n	$\pm 10\%$
Rated DC voltage V_{ndc}	500 to 1100 V
Dielectric	polypropylene

DC FILTERING

Capacitance (μ F)	$I_{rms\ max.}$ (A)	$(I^2t)_{10\ shots}$ (A ² s)	$(I^2t)_{1000\ shots}$ (A ² s)	R_s (m Ω)	R_{th} ($^{\circ}$ C/W)	Part Number
$V_{ndc} = 500\ V$ $V_{rms} = 105\ v\ max$						
20	27	3200	320	5.88	3.53	FFV36J0206K--
25	33	5000	500	4.72	3.14	FFV36J0256K--
$V_{ndc} = 700\ V$ $V_{rms} = 120\ v\ max$						
14	21	2000	200	7.34	3.73	FFV36A0146K--
20	30	4200	420	5.15	3.05	FFV36A0206K--
$V_{ndc} = 900\ V$ $V_{rms} = 150\ v\ max$						
10	19	1600	160	8.21	3.37	FFV36C0106K--
13	25	2800	280	6.33	2.91	FFV36C0136K--
$V_{ndc} = 1100\ V$ $V_{rms} = 180\ v\ max$						
6	13	800	80	11.4	3.71	FFV36L0605K--
9	20	1900	190	7.61	2.92	FFV36L0905K--

LIFETIME EXPECTANCY

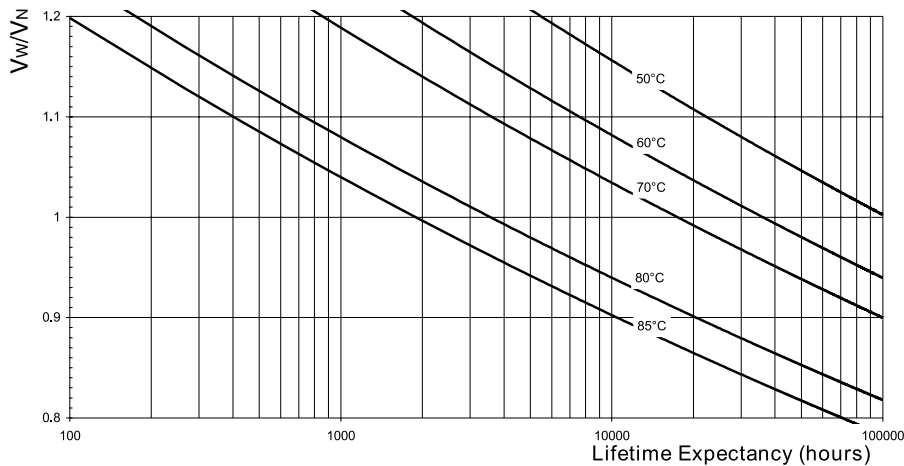

HOT SPOT CALCULATION

$$\theta_{hot\ spot} = \theta_{ambient} + (P_d + P_t) \times (R_{th} + 7.4)$$

$$\theta_{hot\ spot} = \theta_{case} + (P_d + P_t) \times R_{th}$$

with P_d (Dielectric losses) = $Q \times tg\delta_0$

$$\Rightarrow [\frac{1}{2} \times C_n \times (V_{peak\ to\ peak})^2 \times f] \times (2 \times 10^{-4})$$

$$P_t \text{ (Thermal losses)} = R_s \times (I_{rms})^2$$

where C_n in Farad I_{rms} in Ampere f in Hertz
 V in Volt R_s in Ohm θ in $^{\circ}$ C
 R_{th} in $^{\circ}$ C/W R_{th} : R_{th} case/hot spot in $^{\circ}$ C/W

Medium Power Film Capacitors



FFVE/FFVI/FFVA

DC FILTERING

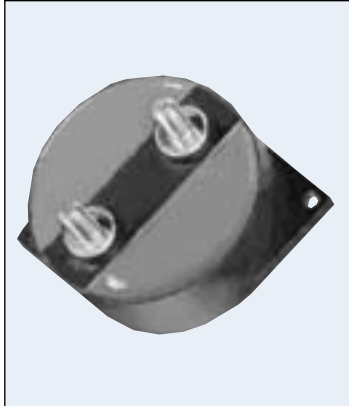

The FFV capacitor is specifically designed for DC filtering, low reactive power.

The series uses a non-impregnated metallized polypropylene or polyester dielectric, which features a controlled self-healing process, specially treated to have a very high dielectric strength in operating conditions up to 85°C.

The FFV special design gives this series a very low level of stray inductance (18 nH to 40 nH). Furthermore, the performance levels of the FFVE capacitor makes them a very interesting alternative to electrolytic technology, because they can withstand much higher levels of surge voltage, very high rms current ratings, and longer lifetimes.

PACKAGING

Self-extinguishing plastic case (V0 = in accordance with UL 94) filled thermosetting resin.

Self-extinguishing thermosetting resin (V0 = in accordance with UL 94; M2F1 = in accordance with NF F 16-101).

DESIGN - Also available with threaded female connections - see FFVA female connectors M5 x 7.5mm

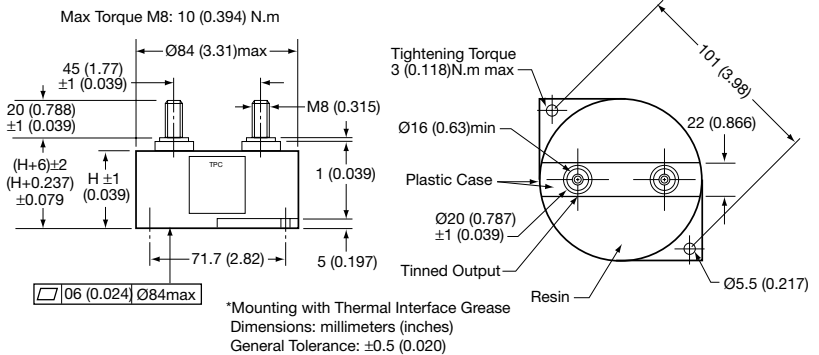

Rs(f) vs FREQUENCY

For frequency higher than 1 kHz use following curve

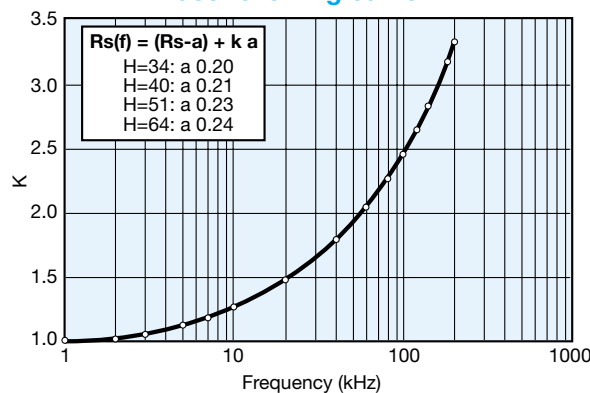

The FFVE for low voltage DC filtering are polyester dielectric capacitors.

Working temperature	-40°C to +85°C (according to the power to be dissipated)
Capacitance range	12µF to 400µF
Capacitance tolerance	±10%
Rated DC voltage	300 to 1100 V
Test voltage between terminals @ 25°C	1.5 x V _n dc 10s (1.25 V _n dc – 10s for FFVI)
Insulation voltage between shorted terminals and earth	4 kVrms



Medium Power Film Capacitors



FFVE/FFVI/FFVA

DC FILTERING

POLYESTER DIELECTRIC

Dimensions: millimeters (inches)

Capacitance (μF)	Height	Irms max. (A)	Ls max. (nH)	Rs (mΩ)	Rth (°C/W)	Part Number*
V_ndc 300 volts						
180	34 (1.339)	100	18	0.8	4.7	FFVE4H0187K--
195	34 (1.339)	100	18	0.8	4.4	FFVE4H1956K--
250	40 (1.575)	100	25	0.6	5.2	FFVE4H0257K--
350	51 (2.008)	100	32	0.8	7.2	FFVE4H0357K--
400	51 (2.008)	110	32	0.8	7.1	FFVE4H0407K--
V_ndc 400 volts						
100	34 (1.339)	80	18	0.7	4.7	FFVE4I0107K--
120	34 (1.339)	100	18	0.6	4.1	FFVE4I0127K--
150	40 (1.575)	100	25	0.7	5.0	FFVE4I0157K--
180	51 (2.008)	80	32	1.0	8.5	FFVE4I0187K--
220	51 (2.008)	100	32	0.9	7.2	FFVE4I0227K--

*Change FFVE to FFVA for female connectors M5 x 7.5mm

POLYPROPYLENE DIELECTRIC

Capacitance (μF)	Height	Irms max. (A)	Ls max. (nH)	Rs (mΩ)	Rth (°C/W)	Part Number*
V_ndc 600 volts						
25	34 (1.339)	90	18	0.7	4.3	FFVE6K0256K--
100	40 (1.575)	100	25	0.6	4.8	FFVE6K0107K--
150	51 (2.008)	110	32	0.9	6.9	FFVE6K0157K--
220	64 (2.520)	100	40	1.0	8.4	FFVE6K0227K--
V_ndc 800 volts						
66	40 (1.575)	100	25	0.7	4.7	FFVE6B0666K--
100	51 (2.008)	90	32	1.0	6.7	FFVE6B0107K--
140	64 (2.520)	100	40	1.3	8.4	FFVE6B0147K--
V_ndc 900 volts						
12	34 (1.339)	70	18	0.9	4.4	FFVE6C0126K--
38	34 (1.339)	100	18	0.7	3.9	FFVE6C0386K--
47	40 (1.575)	100	25	0.8	4.6	FFVE6C0476K--
70	51 (2.008)	100	32	1.2	6.7	FFVE6C0706K--
100	64 (2.520)	90	40	1.1	8.2	FFVE6C0107K--

*Change FFVE to FFVA for female connectors M5 x 7.5mm

LIFETIME EXPECTANCY FOR FFVE

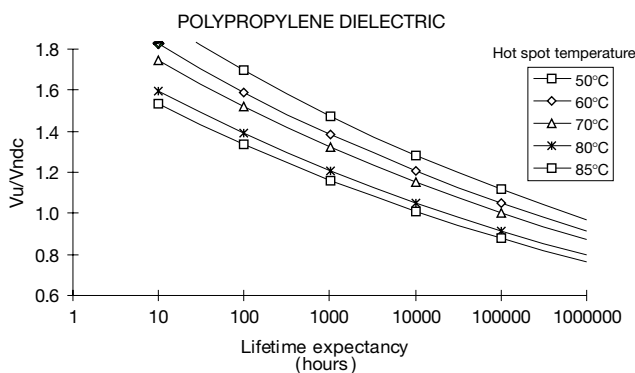

Vu: Operating or working voltage.

LIFETIME EXPECTANCY FOR FFVE

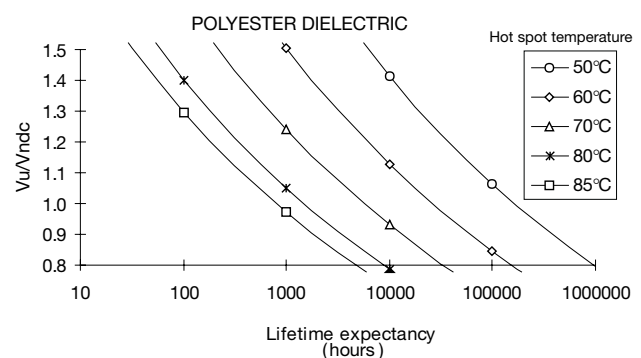

Vu: Operating or working voltage.

Medium Power Film Capacitors



FFVE/FFVI/FFVA

POLYPROPYLENE DIELECTRIC

Capacitance (μF)	Height	I _{rms} max. (A)	L _s max. (nH)	R _s (mΩ)	R _{th} (°C/W)	Part Number*
V_ndc 500 volts						
125	40 (1.575)	90	25	0.6	5.0	FFVI6J1256K--
200	51 (2.008)	90	32	0.8	6.7	FFVI6J0207K--
275	64 (2.520)	90	40	0.9	8.7	FFVI6J2756K--
V_ndc 700 volts						
100	40 (1.575)	100	25	0.6	4.8	FFVI6A0107K--
150	51 (2.008)	100	32	0.9	6.9	FFVI6A0157K--
220	64 (2.520)	100	40	1.0	8.4	FFVI6A0227K--
V_ndc 900 volts						
66	40 (1.575)	100	25	0.7	4.7	FFVI6C0666K--
100	51 (2.008)	90	32	1.0	6.7	FFVI6C0107K--
140	64 (2.520)	100	40	1.3	8.4	FFVI6C0147K--
V_ndc 1100 volts						
47	40 (1.575)	100	25	0.8	4.6	FFVI6L0476K--
70	51 (2.008)	100	32	1.2	6.7	FFVI6L0706K--
100	64 (2.520)	90	40	1.1	8.2	FFVI6L0107K--

*Change FFVI to FFVA for female connectors

DC FILTERING

LIFETIME EXPECTANCY FOR FFVI

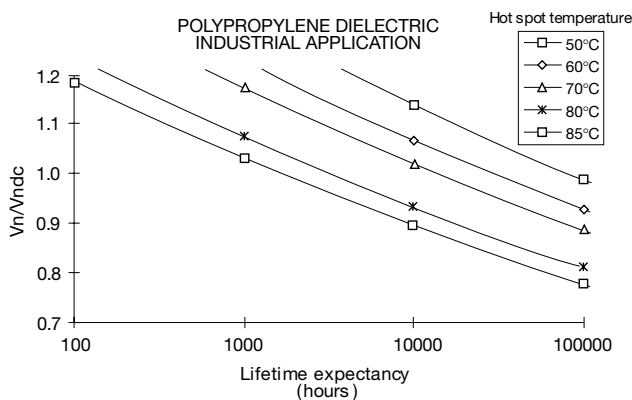

V_u: Operating or working voltage.

HOT SPOT CALCULATION

$$\theta_{\text{hot spot}} = \theta_{\text{case}} + (P_d + P_t) \times R_{\text{th}}$$

with P_d (Dielectric losses) = $Q \times \text{tg}\delta_0$
 $\Rightarrow [\frac{1}{2} \times C_n \times (V_{\text{peak to peak}})^2 \times f] \times \text{tg}\delta_0$
 (see $\text{tg}\delta_0$ vs dielectric page 3)

$$P_t \text{ (Thermal losses)} = R_s \times (I_{\text{rms}})^2$$

where C_n in Farad I_{rms} in Ampere f in Hertz
 V in Volt R_s in Ohm θ in °C
 R_{th} in °C/W R_{th} hot spot/bottom case

Medium Power Film Capacitors



FFLI Design

DC FILTERING

DC FILTERING



PACKAGING - also available with female connections

Cylindrical resin-filled aluminum case.

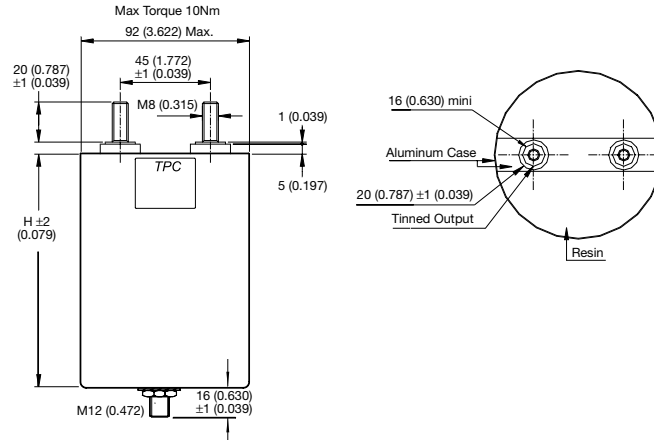

ELECTRICAL CHARACTERISTICS

Capacitance range C_n	160 μ F to 390 μ F
Tolerance on C_n	$\pm 10\%$
Rated DC voltage V_{ndc}	1000 to 1200 V
Maximum rms current I_{rms} max	60 Arms
Stray inductance L_s	60 nH to 85 nH
Test voltage between terminals @ 25°C	1.5 V_{ndc} 10 s
Test voltage between terminals and case @25°C	4 kVrms @ 50 Hz during 1 min.

POLYPROPYLENE DIELECTRIC

mm (inches)

Capacitance (μ F)	Height	I_{rms} (A)	L_s (nH)	R_s (m Ω)	R_{th} ($^{\circ}$ C/W)	Weight (kg)	Part Number
$V_{ndc} = 1000$ V							
390	145 (5.709)	60	85	5.2	2.4	1.2	FFLI6L0397K--
230	97 (3.819)	60	60	3.5	3.1	0.8	FFLI6L0237K--
$V_{ndc} = 1200$ V							
270	145 (5.709)	60	85	6.1	2.4	1.2	FFLI6U0277K--
160	97 (3.819)	60	60	4.1	3.1	0.8	FFLI6U0167K--

GENERAL CHARACTERISTICS

Maximum overvoltage (V_s): $V_s = 1.8 V_{ndc}$

Voltages and overvoltages withstanding for 100,000 hours at V_{ndc} and 50°C hot spot temperature:

Voltage Value	Duration
$V_{dc} = 1.67 \times V_{ndc}$	$\leq 100ms$ _1 time per day
$+V_{dc} = 1.5 \times V_{ndc}$	5 min._1 time per day
$+V_{dc} = 1.3 \times V_{ndc}$	2.5 hours_1 time per day
$+V_{dc} = 1.1 \times V_{ndc}$	40% of the On-load duration
$+V_{do} = V_{ndc}$	$\cong 50\%$ of the On-load duration
Sum	100,000 hours

LIFETIME EXPECTANCY

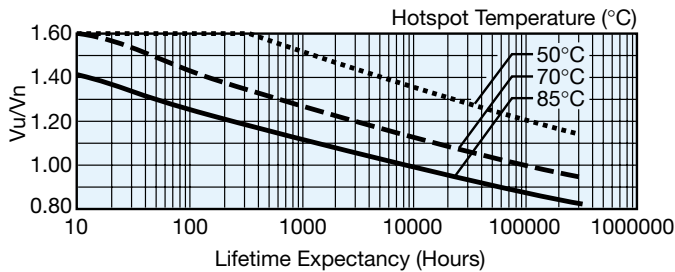

V_u : Operating or working voltage.

HOT SPOT CALCULATION

$$\theta_{hot\ spot} = \theta_{ambient} + (P_d + P_t) \times R_{th}$$

$$\text{with } P_d \text{ (Dielectric losses)} = Q \times tg\delta_0$$

$$\Rightarrow [\frac{1}{2} \times C_n \times (V_{peak\ to\ peak})^2 \times f] \times (2 \times 10^{-4})$$

$$P_t \text{ (Thermal losses)} = R_s \times (I_{rms})^2$$

where C_n in Farad I_{rms} in Ampere f in Hertz
 V in Volt R_s in Ohm θ in $^{\circ}$ C
 R_{th} in $^{\circ}$ C/W



Medium Power Film Capacitors



FFLT Design

DC FILTERING



PACKAGING

Cylindrical resin-filled aluminum case.

Max. Torque 4Nm

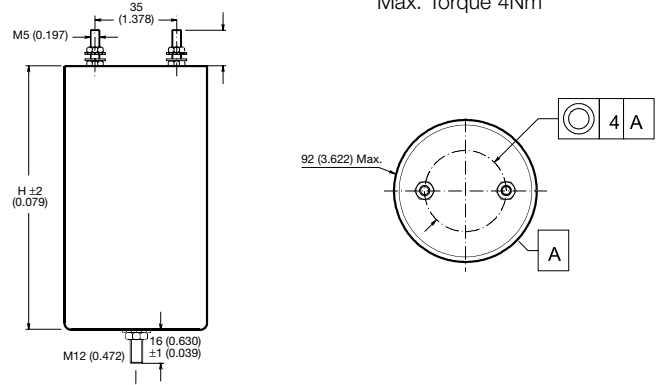

ELECTRICAL CHARACTERISTICS

Capacitance range C_n	160 μ F to 600 μ F
Tolerance on C_n	$\pm 10\%$
Rated DC voltage V_{ndc}	600 to 900 V
Maximum rms current I_{rms} max	40 Arms
Stray inductance L_s	60 nH to 85 nH
Test voltage between terminals @ 25°C	1.5 V_{ndc} 10 s
Test voltage between terminals and case @25°C	2.5 kVrms @ 50 Hz during 1 min.

POLYPROPYLENE DIELECTRIC

mm (inches)

Capacitance (μ F)	Height	I_{rms} (A)	L_s (nH)	R_s (m Ω)	R_{th} ($^{\circ}$ C/W)	Weight (kg)	Part Number
$V_{ndc} = 600$ V							
600	145 (5.709)	40	85	2.7	2.4	1.2	FFLT6K0607K--
350	97 (3.819)	40	60	2	3.1	0.8	FFLT6K0357K--
$V_{ndc} = 750$ V							
390	145 (5.709)	40	85	3.1	2.4	1.2	FFLT6A0397K--
230	97 (3.819)	40	60	2.2	3.1	0.8	FFLT6A0237K--
$V_{ndc} = 900$ V							
270	145 (5.709)	40	85	3.6	2.4	1.2	FFLT6C0277K--
160	97 (3.819)	40	60	2.5	3.1	0.8	FFLT6C0167K--

GENERAL CHARACTERISTICS

Climatic category 40/85/56 (IEC 68)

Maximum overvoltage	Peak value	Maximum duration	
	2 V_{ndc}	100 ms	1 time per week
1.5 V_{ndc}	100 ms	1 time per day	
1.3 V_{ndc}	1 min	1 time per day	
1.1 V_{ndc}	1 h	1 time per day	

LIFETIME EXPECTANCY

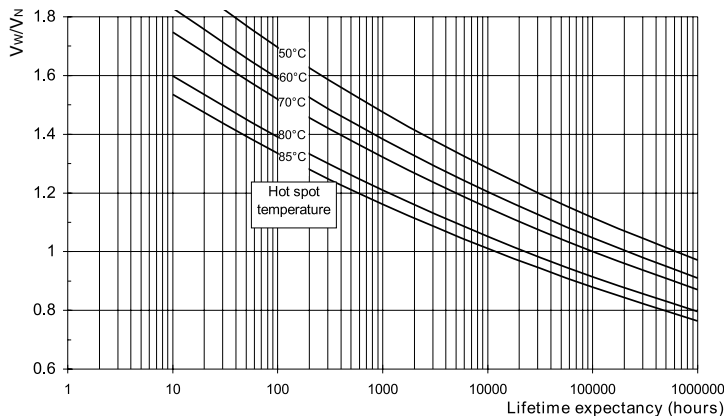

STANDARDS

- IEC 1071-1
- IEC 1071-2: Power electronic capacitors
- IEC 68-1: Environmental testing
- IEC 77: Rules for electric traction equipment
- UL 94: Fire requirements
- NF F 16-101
- NF F 16-102: Fire and smoke requirements

HOT SPOT CALCULATION

$$\theta_{hot\ spot} = \theta_{ambient} + (P_d + P_t) \times R_{th}$$

with P_d (Dielectric losses) = $Q \times \tan\delta_0$
 $\Rightarrow [\frac{1}{2} \times C_n \times (V_{peak\ to\ peak})^2 \times f] \times (2 \times 10^{-4})$

$$P_t \text{ (Thermal losses)} = R_s \times (I_{rms})^2$$

where C_n in Farad I_{rms} in Ampere f in Hertz
 V in Volt R_s in Ohm θ in $^{\circ}$ C
 R_{th} in $^{\circ}$ C/W

Medium Power Film Capacitors



FFLC/FFLP Design

DC FILTERING

DC FILTERING

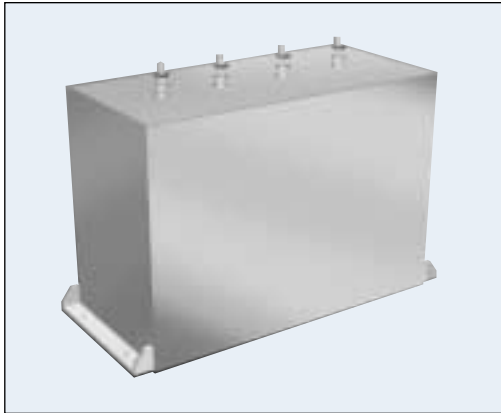

PACKAGING

Non-painted rectangular resin filled aluminum case 4 x M10 terminals.

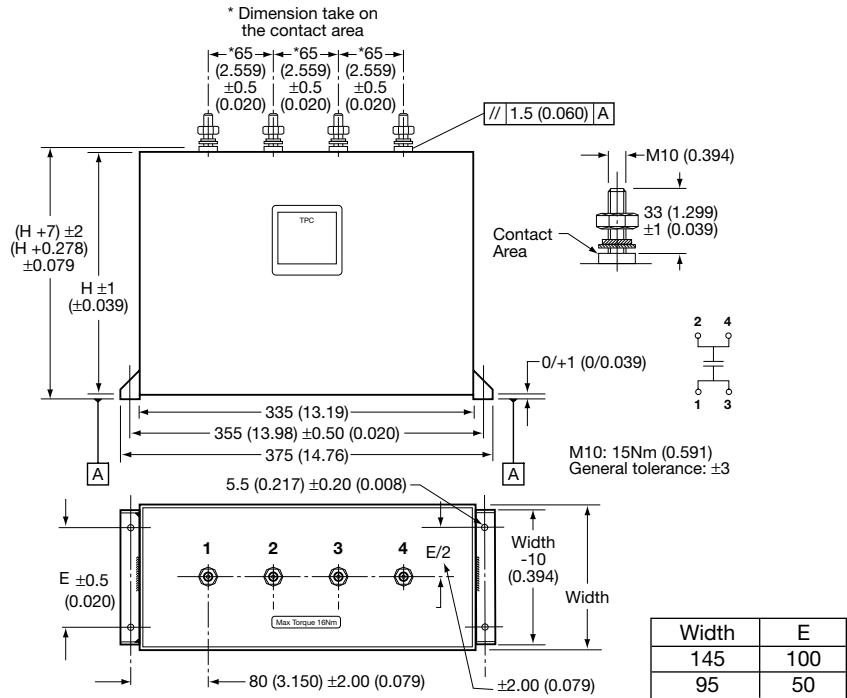

ELECTRICAL CHARACTERISTICS

Capacitance range C_n	1120 μ F to 6600 μ F (other values available upon request)
Tolerance on C_n	$\pm 10\%$
Rated DC voltage V_{ndc}	600 to 1100 V
Maximum rms current $I_{rms\ max}$	170 Arms to 300 Arms
Stray inductance L_s	28 nH to 38 nH

POLYPROPYLENE DIELECTRIC

Dimensions: millimeters (inches)

Capacitance (μ F)	Height	Width	I_{rms} (A)	L_s (nH)	R_s (m Ω)	R_{th} ($^{\circ}$ C/W)	Weight (kg)	Part Number
$V_{ndc} = 600\ V$								
6600	240 (9.449)	145 (5.709)	300	38	0.19	2.2	15.5	FFLP6K6607K--
4200	170 (6.693)	145 (5.709)	200	30	0.28	3.3	11.3	FFLP6K4207K--
$V_{ndc} = 900\ V^*$								
4300	240 (9.449)	145 (5.709)	300	38	0.52	1.1	15.5	FFLC6C4307K--
2730	170 (6.693)	145 (5.709)	170	30	0.75	1.6	11.3	FFLC6C2737K--
2530	240 (9.449)	95 (3.740)	300	35	0.36	0.8	10.3	FFLC6C2537K--
1600	170 (6.693)	95 (3.740)	170	28	0.51	1.2	7.3	FFLC6C1607K--
$V_{ndc} = 1100\ V^{**}$								
3000	240 (9.449)	145 (5.709)	300	38	0.60	1.1	15.5	FFLC6L3007K--
1900	170 (6.693)	145 (5.709)	170	30	0.87	1.6	11.3	FFLC6L1907K--
1750	240 (9.449)	95 (3.740)	300	35	0.41	0.8	10.3	FFLC6L1757K--
1120	170 (6.693)	95 (3.740)	170	28	0.59	1.2	7.3	FFLC6L1127K--

*Available at 1000 VDC upon request

**Available at 1200 VDC upon request

Medium Power Film Capacitors



FFLC/FFLP Design

LIFETIME EXPECTANCY

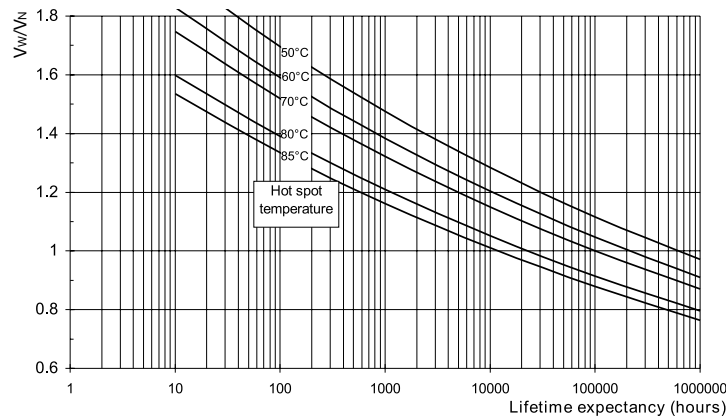

DC FILTERING

GENERAL CHARACTERISTICS

Climatic category 40/85/56 (IEC 68)

FFLC overvoltage: (V_s): $V_s = 2 V_n$ dc

Maximum overvoltage	Peak value	Maximum duration
	1.67 V_n dc	100 ms 1 time per week
	1.25 V_n dc	100 ms 1 time per day
	1.1 V_n dc	1 min 1 time per day

Test voltage between terminals @ 25°C
1.5 x V_n dc for 10s

Test voltage between terminals and case @ 25°C
@ 4 kVrms @ 50 Hz for 1 min.

STANDARDS

- IEC 1071-1
- IEC 1071-2: Power electronic capacitors
- IEC 68-1: Environmental testing
- IEC 77: Rules for electric traction equipment
- UL 94: Fire requirements
- NF F 16-101
- NF F 16-102: Fire and smoke requirements

HOT SPOT CALCULATION

$$\theta_{hot\ spot} = \theta_{ambient} + (P_d + P_t) \times R_{th}$$

with P_d (Dielectric losses) = $Q \times tg\delta_0$
 $\Rightarrow [\frac{1}{2} \times C_n \times (V_{peak\ to\ peak})^2 \times f] \times (2 \times 10^{-4})$

$$P_t \text{ (Thermal losses)} = R_s \times (I_{rms})^2$$

where C_n in Farad I_{rms} in Ampere f in Hertz
 V in Volt R_s in Ohm θ in °C
 R_{th} in °C/W

Medium Power Film Capacitors



FSG – Do not use for new design

CLAMPING



TECHNOLOGY

Metallized polypropylene dielectric specially treated to withstand high DC voltage stresses up to 85°C.

Controlled self-healing.

Internal geometry and connections specially developed for high currents (I_{rms} up to 80 A).

No liquid impregnant.

CLAMPING

Max torque: 10Nm (M8)
4.5Nm (M6)

Dimensions: mm (inches)

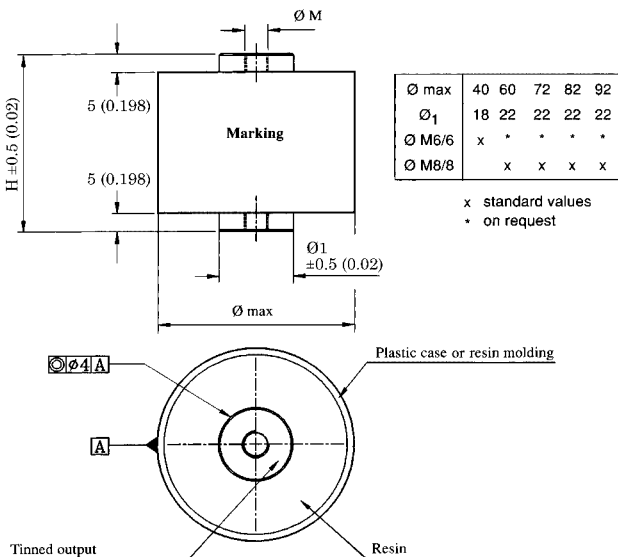

MARKING

Logo TPC

FSG

Capacitance and tolerance in clear

Nominal voltage in clear

RMS current in clear

Date of manufacture (IEC coding)

APPLICATIONS

Recovery capacitor for G.T.O. switching (secondary snubber or clamp capacitor).

High current DC filtering.

Special metallization for DC voltage and high currents.

PACKAGING

Cylindrical plastic case.

Outputs: threaded inserts either M6 or M8.

Filled with thermosetting resin.

Vibrations and shocks resistant to IEC 77.

ELECTRICAL CHARACTERISTICS

Climatic category	40/085/56
Working temperature	-40°C to +85°C (according to the power to be dissipated)
Capacitance range C _n	2µF to 40µF
Tolerance on C _n	±10%
Rated DC voltage V _{ndc}	900 to 1350 V
Allowable overvoltages	V _s = 1.1 V _{ndc} – 1/3 of the time 1.3 V _{ndc} – 1 min./day 2 V _{ndc} – 100 ms/day
DC test voltage between terminals	10s at 20°C ± 15°C V _{edc} – 1.5 V _{ndc} (IEC 1071)
RMS current	See table values
Impulse current	See table values
Series inductance L _s	≤ 10 nH
Tangent of loss angle	Tgδ

STANDARDS

IEC 1071-1

IEC 1071-2: Power electronic capacitors

IEC 68-1: Environmental testing

IEC 77: Rules for electric traction equipment

UL 94: Fire requirements

NF F 16-101

NF F 16-102: Fire and smoke requirements

HOT SPOT CALCULATION

$$\theta_{\text{hot spot}} = \theta_{\text{case}} + (P_d + P_t) \times R_{\text{th}}$$

with P_d (Dielectric losses) = Q x tgδ₀

$$\Rightarrow [\frac{1}{2} \times C_n \times (V_{\text{peak to peak}})^2 \times f] \times (2 \times 10^{-4})$$

$$P_t \text{ (Thermal losses)} = R_s \times (I_{\text{rms}})^2$$

where C_n in Farad I_{rms} in Ampere f in Hertz
V in Volt R_s in Ohm θ in °C
R_{th} in °C/W

Medium Power Film Capacitors



FSG – Do not use for new design

CLAMPING

TABLE OF VALUES

Dimensions: millimeters (inches)

Cn (μ F)	Diam. Ø max. Height (H)	rms max. (A)	Rs (m Ω)	I ² t (A ² s)	Rth case/ hot spot	Part Number
V_{ndc} 900 V						
4	40 / 52 (1.575 / 2.047)	15	2.7	2	18	FSG66C0405K--
9	60 / 52 (2.362 / 2.047)	30	1.4	10	8.8	FSG86C0905K--
14	72 / 52 (2.835 / 2.047)	50	1.1	25	5.8	FSG86C0146K--
20	82 / 52 (3.228 / 2.047)	70	0.9	50	4.1	FSG86C0206K--
40	92 / 62 (3.622 / 2.440)	80	0.9	75	4.9	FSG86C0406K--
V_{ndc} 1000 V						
3	40 / 52 (1.575 / 2.047)	15	3.3	1.3	19	FSG66L0305K--
8	60 / 52 (2.362 / 2.047)	30	1.4	9	9	FSG86L0805K--
12	72 / 52 (2.835 / 2.047)	50	1.1	20	6.4	FSG86L0126K--
16	82 / 52 (3.228 / 2.047)	70	1.0	35	4.6	FSG86L0166K--
32	92 / 62 (3.622 / 2.440)	80	0.9	60	4.7	FSG86L0326K--
V_{ndc} 1150 V						
2.5	40 / 52 (1.575 / 2.047)	15	3.4	1.2	19	FSG66U0255K--
6.5	60 / 52 (2.362 / 2.047)	30	1.4	8	8.5	FSG86U0655K--
9	72 / 52 (2.835 / 2.047)	50	1.2	15.5	6.5	FSG86U0905K--
13	82 / 52 (3.228 / 2.047)	70	1.0	32	4.4	FSG86U0136K--
26	92 / 62 (3.622 / 2.440)	80	1.0	49	5.1	FSG86U0266K--
V_{ndc} 1350 V						
2	40 / 52 (1.575 / 2.047)	15	3.6	1.1	17	FSG66V0205K--
4.5	60 / 52 (2.362 / 2.047)	30	1.8	5.5	9	FSG86V0455K--
7	72 / 52 (2.835 / 2.047)	50	1.4	9.5	6	FSG86V0705K--
9	82 / 52 (3.228 / 2.047)	70	1.1	22	4.6	FSG86V0905K--
18	92 / 62 (3.622 / 2.440)	80	1.1	35	4.6	FSG86V0186K--

CLAMPING

Medium Power Film Capacitors



FSM – Do not use for new design

CLAMPING



APPLICATIONS

Recovery capacitor for G.T.O. switching (secondary snubber or clamp capacitor).
High current DC filtering.

TECHNOLOGY

Metallized polypropylene dielectric specially treated to withstand high DC voltage stresses up to 85°C.

Controlled self-healing.

Internal geometry and connections specially developed for high currents (I_{rms} up to 100 A).

No liquid impregnant.

Special metallization for DC voltage and high currents.

PACKAGING

Self-extinguishing rectangular plastic case (in accordance with UL 94 VO) (12 kV/50 Hz isolation).

Filled with thermosetting resin.

M8 outputs.

Fixing in two planes.

Vibrations and shocks resistant to IEC 77.

Average weight 0.95 kg.

CLAMPING

CLAMPING

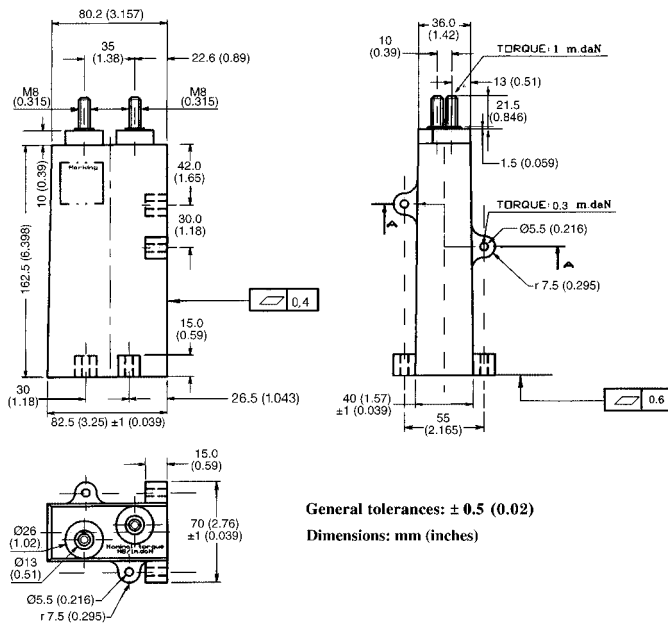

ELECTRICAL CHARACTERISTICS

Climatic category	40/085/56
Working temperature	-40°C to +85°C (according to the power to be dissipated)
Capacitance range C _n	20µF to 54µF
Tolerance on C _n	±10%
Rated DC voltage V _{ndc}	750 to 1350 V
Allowable overvoltages	V _s = 1.1 V _{ndc} – 1/3 of the time 1.3 V _{ndc} – 1 min./day 2 V _{ndc} – 100 ms/day for V _{ndc} ≤ 1150 V 1.75 V _{ndc} – 100 ms/day for V _{ndc} = 1350 V
DC test voltage between 10s at 20°C ± 15°C terminals	V _{edc} – 1.5 V _{ndc} (IEC 1071)
RMS current	I _{rms} max. = 65 to 105 A
Impulse current	I _{2.t} max. = 100 to 270 A ² s
Tangent of loss angle	Tgδ: see table of values
Series inductance L _s	≤ 25 nH
Thermal resistance	R _{th} ambient/hot spot = 9.2°C/W R _{th} case/hot spot = 3.3°C/W

MARKING

Logo TPC

FSM

Capacitance and tolerance in clear

Nominal voltage in clear

RMS current in clear

Date of manufacture (IEC coding)

Medium Power Film Capacitors



FSM – Do not use for new design

CLAMPING

1) RECOVERY OF G.T.O. SWITCHING ENERGY

Typical application

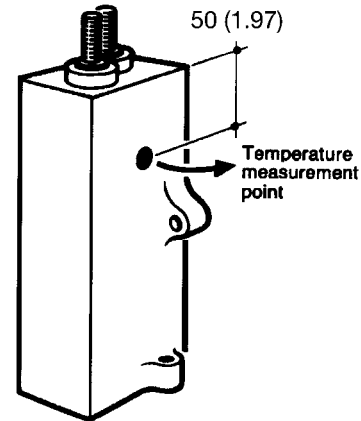
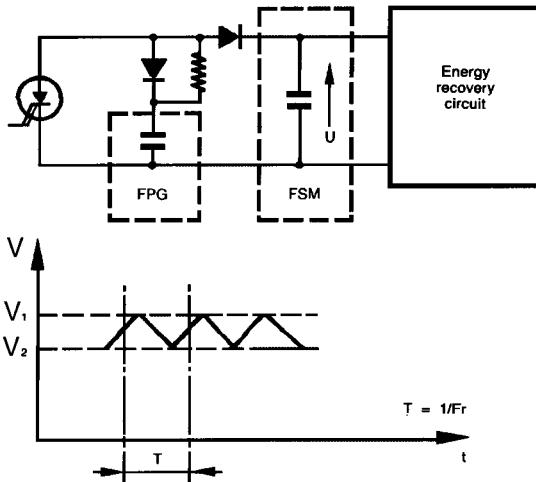

CLAMPING

Choice of voltage:

$$V_1 \leq V_{n,dc}$$

Repetitive surge:

1.1 $V_{n,dc}$ – 1/3 of the time

Non-repetitive surge:

1.3 $V_{n,dc}$ – 1 min./day

Occasional max. surge:

2 $V_{n,dc}$ – 100 ms/day for $V_{n,dc} \leq 1150$ V

1.75 $V_{n,dc}$ – 100 ms/day for $V_{n,dc} = 1350$ V

RMS current limits:

The currents given in the tables are maximum. The thermal limits of the dielectric (85°C) must be respected.

The self-heating can be calculated from the series resistance, $Tg\delta$ and the thermal resistance given in the table of values

$$\Delta\theta = P \times R_{th} \leq 85^\circ\text{C} - \theta_{\text{ambient}}$$

R_{th} : is given for still air with the capacitor not being subjected to any other heat source.

$$P = (I_{rms})^2 \times R_s + \frac{\pi}{2} \times C (V_1 - V_2)^2 \times f_r \times 10^{-4}$$

Temperature measuring point*

Measurement of the case temperature (θ_B) together with the losses gives the temperature of the hot spot.

$$\theta = (R_{thB} \times P) + \theta_B \leq 85^\circ\text{C}$$

*Important for series/parallel operations.

Important

Due to the modular nature of these capacitors series and parallel assemblies can be made to increase the capacitance and/or voltage.

Ensure that suitable sized connections are used so that the capacitors will not be overheated. The inductance of the connections must be low enough to ensure equal current sharing of capacitors in parallel.

For series assemblies, connect across each capacitor a resistor of value

$$R \# 30 \text{ M}\Omega/\text{C in } \mu\text{F} \\ (1.5 \text{ M}\Omega \text{ for } C = 20 \mu\text{F}).$$

2) DC FILTERING

Idem paragraph 1.

Cn (μF)	V _{n,dc} (V)	I _{rms} * maxi.* (A)	(I ² .t) max. (A ² .s)	Tgδ (f→kHz) (10 ⁻⁴)	R _s (mΩ)	References
54	750	105	270	2 + 3.4 f	1	FSM26A0546K--
42	900	100	220	2 + 2.8 f	1.05	FSM26C0446K--
33	1000	95	170	2 + 2.3 f	1.1	FSM26L0336K--
28	1150	85	150	2 + 2 f	1.15	FSM26U0286K--
20	1350	65	100	2 + 1.6 f	1.25	FSM26V0206K--

Table of Values

*Function of power dissipation

Medium Power Film Capacitors



FSB

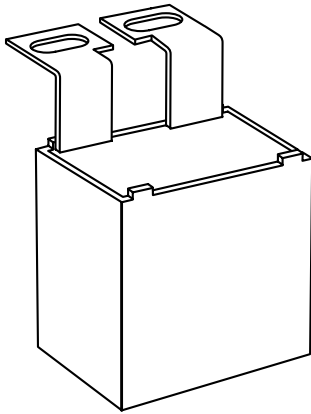

Metallized polypropylene dielectric capacitor with controlled self-healing.

Reinforced metallization developed for high impulse currents. Axial connections specially developed to reduce series inductance and to provide rigid mechanical mounting.

APPLICATIONS

IGBT protection
IGBT clamping

PACKAGING

Parallelepipedic plastic case filled with thermosetting resin.
Outputs: Thin copper plate designed for M5 or M6 screw.

ELECTRICAL CHARACTERISTICS

Capacitance range C_n	0.47 μ F to 2.5 μ F
Tolerance on C_n	$\pm 10\%$
Rated DC voltage V_{ndc}	850 to 2000 V
Stray inductance	≤ 25 nH
RMS current	I_{rms} max. = up to 28 A The currents shown in the tables are maximum. It is necessary to respect the thermal limits of the dielectric 85°C see "Hot spot temperature calculation"
Insulation resistance	$R_i \times C \geq 30,000$ s
Impulse current	$I^2.t$ max. = up to 1.69 A ² s Spikes or peak currents in the capacitors may cause a deterioration of the bonding between the metallization and the connections. These bonds are capable of withstanding only a limited amount of energy for each spike. The table shows the maximum energy permitted in the form ($I^2.t$), where I is in Ampere, and t is in seconds.
Note: The formula ($I^2.t$) replaces dV/dt which is less easy to use as it is not an expression of energy ($I = C.dV/dt$). This type of capacitor has been designed to withstand high ($I^2.t$) values.	
Variation of capacitance with temperature	$\frac{\Delta C}{C} \leq \pm 2\%$ between -40 and 85°C
Climatic category	40/085/56 (IEC 68)
Test voltage between terminals @ 25°C	2 x V_{ndc} during 10s
Withstanding voltage between terminals and case @ 25°C	@ 3 kVrms @ 50 Hz during 1 min.

PROTECTION

Medium Power Film Capacitors



FSB

DESIGN

Plastic case resin filled
Dimensions: millimeters (inches)

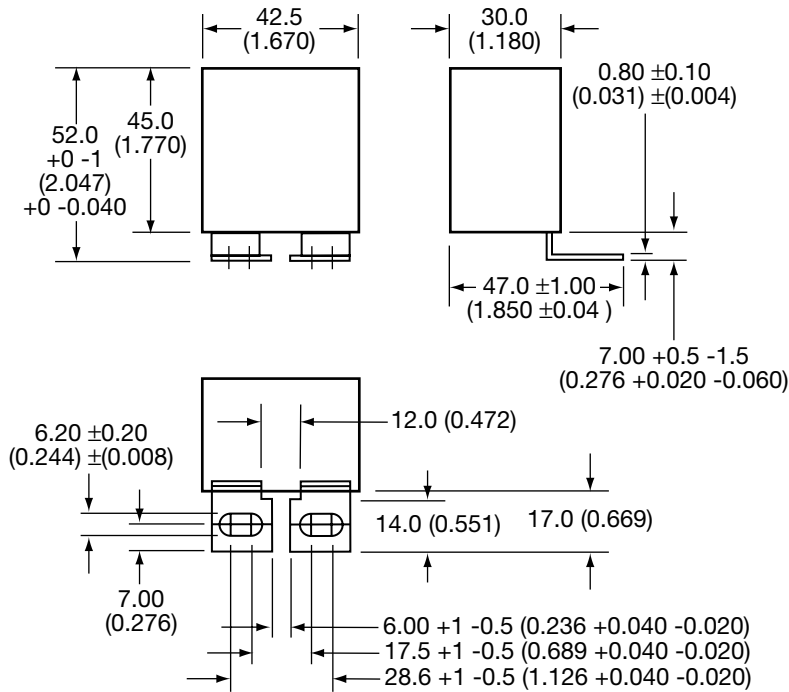

General Tolerances: ±0.50 mm (±0.020)

Capacitance (μF)	(I ² t) (A ² s)	I _{rms max.} (A)	R _s (mΩ)	R _{th} (°C/W)	Part Number
FSB 850V					
	V _{ndc} = 850V	V _{peak} = 1200V	V _{rms} = 450V	V _s = 1500V	
2	0.99	25	3.4	19.1	FSB16B0205K--
2.2	1.19	28	3.1	18.6	FSB16B0225K--
2.5	1.54	28	2.7	17.8	FSB16B0255K--
FSB 1200V					
	V _{ndc} = 1200V	V _{peak} = 1600V	V _{rms} = 560V	V _s = 2000V	
1	1.47	25	3.6	17.2	FSB16U0105K--
1.2	1.69	26	3.4	17.5	FSB16U0125K--
1.5	1	26	3.4	17.5	FSB16U0155K--
FSB 2000V					
	V _{ndc} = 2000V	V _{peak} = 2400V	V _{rms} = 700V	V _s = 2600V	
0.47	0.41	22	6.3	19.4	FSB16N0474K--
0.56	0.62	23	5.2	17.9	FSB16N0564K--
0.68	0.91	24	4.4	17.3	FSB16N0684K--

PROTECTION

STANDARDS

IEC 1071-1, IEC 1071-2: Power electronic capacitors

TANGENT OF LOSS ANGLE (TANδ₀) FOR POLYPROPYLENE DIELECTRIC

Polypropylene has a constant dielectric loss factor of 2x10⁻⁴ irrespective of temperature and frequency (up to 1 MHz).

IGBT SNUBBER

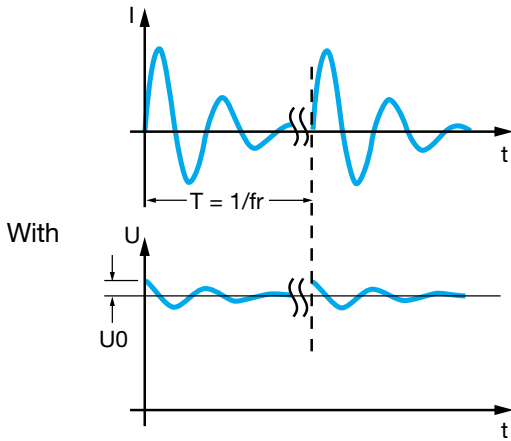
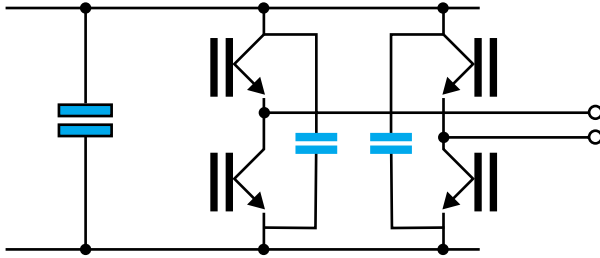

L = stray inductance IGBT + capacitor

R = serial resistance IGBT + capacitor

$$I_{eff} = \sqrt{\left[\frac{C\beta_0^2 \times U_0}{2j\beta} \right]^2} \times \frac{1}{T} \times \left[\frac{e^{-2\alpha \times T}}{\beta^2 + \alpha^2} \times [\beta \sin(2\beta \times T) - \alpha \times \cos(2\beta \times T)] + \frac{1}{\alpha} \times e^{-2\alpha \times T} + \frac{\alpha}{\beta^2 + \alpha^2} - \frac{1}{\alpha} \right]$$

with $\beta_0 = \sqrt{\frac{1}{LC}}$; $\alpha = \frac{R}{2L}$; $\beta = \sqrt{\beta_0^2 - \alpha^2}$

MARKING

TPC logo

Capacitance and tolerance in clear

Nominal DC voltage in clear

RMS current in clear

Date of manufacture (IEC coding)

HOT SPOT TEMPERATURE CALCULATION

$$\theta_{hot\ spot} = \theta_{ambient} + (P_d + P_t) \times R_{th}$$

with P_d (Dielectric losses) = $Q \times \text{tg}\delta_0$
 $\Rightarrow [\frac{1}{2} \times C_n \times (V_{ripple\ peak\ to\ peak})^2 \times f] \times (2 \times 10^{-4})$
 P_t (Thermal losses) = $R_s \times (I_{rms})^2$
 R_{th} : $R_{th\ ambient} / \text{hot spot}$ in °C/W

where C_n in Farad I_{rms} in Ampere f in Hertz
 V in Volt R_s in Ohm θ in °C

Due to the design of the capacitor and its technology, the thermal impedance between the terminations and the core of the capacitor is low, it is necessary to take care that the capacitor is never overheated by use of wrongly sized connections.

Do not use the capacitor as a heat sink.

Due to the complexity of the IGBT / capacitor thermal exchanges, we recommend that thermal measurements shall be made on the different components. We would be pleased to advise you on specific problems.

WORKING TEMPERATURE

(according to the power to be dissipated) -40°C to +85°C

Medium Power Film Capacitors



FPX

PROTECTION



APPLICATIONS

Protection of thyristors.
Protection of gate turn-off thyristor (G.T.O.).
Clamping (Secondary snubber).

TECHNOLOGY

Metallized polypropylene dielectric capacitor with controlled self-healing.
Reinforced metallization developed for high impulse currents.
Axial connections specially developed to reduce series inductance and to provide rigid mechanical mounting.

PACKAGING

Cylindrical in plastic case filled with thermosetting resin.
Outputs: threaded inserts either M6 or M8.

ELECTRICAL CHARACTERISTICS

Capacitance range C_n	0.5 μ F to 6 μ F
Tolerance on C_n	$\pm 5\%$
Rated DC voltage V_{ndc}	1000 to 3000 V
Peak voltage V_{peak}	1600 to 4000 V
Allowable overvoltage V_s (for 10 s/day)	2000 to 4600 V
Stray inductance	5 to 20 nH
RMS current	I_{rms} max. = up to 160 A The currents shown in the tables are maximum. It is necessary to respect the thermal limits of the dielectric 85°C see "Hot spot temperature calculation"
Insulation resistance	$R_i \times C \geq 30,000$ s
Impulse current	$I^2.t$ maxi. = up to 729 A ² .s Spikes or peak currents in the capacitors may cause a deterioration of the bonding between the metallization and the connections. These bonds are capable of withstanding only a limited amount of energy for each spike. The table shows the maximum energy permitted in the form ($I^2.t$), where I is in Ampere, and t is in seconds.
Note: The formula ($I^2.t$) replaces dV/dt which is less easy to use as it is not an expression of energy ($I = C.dV/dt$). This type of capacitor has been designed to withstand high ($I^2.t$) values.	
Variation of capacitance with temperature	$\frac{\Delta C}{C} \leq \pm 2\%$ between -40 and 85°C
Climatic category	40/085/56 (IEC 68)
Test voltage between terminals @ 25°C	V_s for 10s
Test voltage between terminals and case @ 25°C	@ 4 kVrms @ 50 Hz for 1 min.

PROTECTION

For higher power protection devices and further information please see PPX Series in Capacitor for High Power Electronics available on AVX website: www.avxcorp.com

Medium Power Film Capacitors



FPX General Description / Application Notes

PROTECTION

G.T.O.

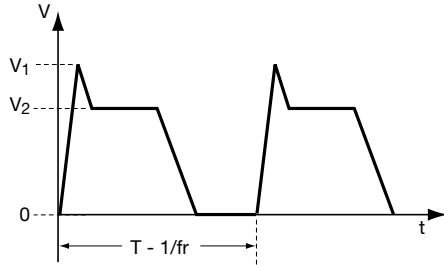

Choice of voltage: $V_1 \leq V_{peak}$
 $V_2 \leq V_{nDC}$

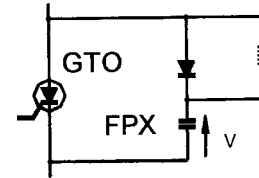

Nominal DC voltage (V_{nDC}) and peak voltage (V_{peak}) are given in the tables.

THYRISTOR

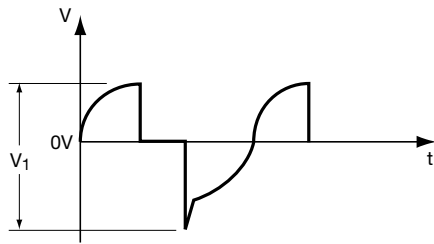

Choice of voltage: $V_1 \leq V_{peak}$

Note that V_1 is the voltage peak to peak and cannot be symmetrical vs 0 V

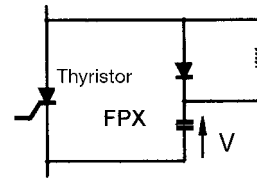

Peak voltage is given in the tables.

CLAMPING

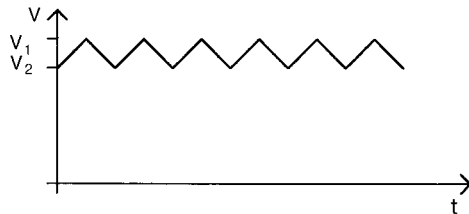

Choice of voltage: $V_1 \leq V_{peak}$
 $V_2 \leq V_{nDC}$

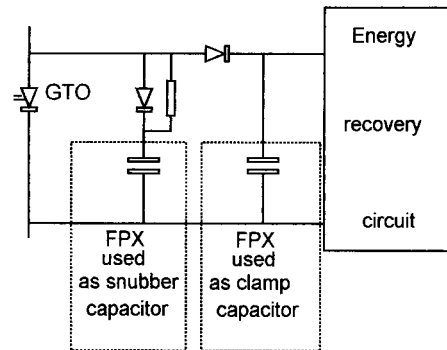

Nominal DC voltage (V_{nDC}) and peak voltage (V_{peak}) are given in the tables.

PROTECTION

Medium Power Film Capacitors



FPX Table of Values

PROTECTION

Dimensions: millimeters (inches)

Cn (μF)	Case Type	Dimensions				I ² .t max. (A ² .s)	I _{rms} max. (A)	R _s (mΩ)	R _{th} (°C/W)	Part Number
		H* ±0.5 (±0.020)	h ±2 (±0.079)	D max.	d ±0.1					
FPX 2000 V										
		V_{ndc} = 1000 V		V_{peak} = 1600 V		V_{rms} = 560 V		V_s = 2000 V		
1	Plastic case M6/6	52 (2.072)	5 (0.197)	40 (1.575)	18 (0.709)	2	15	2.4	14	FPX66N0105J--
2	Plastic case M8/8	52 (2.072)	5 (0.197)	60 (2.362)	22 (0.866)	8	30	1.2	6.1	FPX86N0205J--
3	Plastic case M8/8	52 (2.072)	5 (0.197)	72 (2.835)	22 (0.866)	18	45	0.9	4.5	FPX86N0305J--
3.5	Plastic case M8/8	52 (2.072)	5 (0.197)	72 (2.835)	22 (0.866)	25	50	0.85	4.5	FPX86N0355J--
4	Plastic case M8/8	52 (2.072)	5 (0.197)	82 (3.228)	22 (0.866)	32	60	0.75	3.5	FPX86N0405J--
5	Plastic case M8/8	52 (2.072)	5 (0.197)	82 (3.228)	22 (0.866)	50	70	0.65	2.5	FPX86N0505J--
FPX 2500 V										
		V_{ndc} = 1300 V		V_{peak} = 2000 V		V_{rms} = 700 V		V_s = 2500 V		
0.5	Plastic case M6/6	52 (2.072)	5 (0.197)	40 (1.575)	18 (0.709)	1	15	3	14	FPX66P0504J--
1	Plastic case M8/8	52 (2.072)	5 (0.197)	60 (2.362)	22 (0.866)	3	20	2.3	10.5	FPX86P0105J--
1.5	Plastic case M8/8	52 (2.072)	5 (0.197)	60 (2.362)	22 (0.866)	7	30	1.5	6.1	FPX86P0155J--
2	Plastic case M8/8	52 (2.072)	5 (0.197)	72 (2.835)	22 (0.866)	12.7	40	1.1	4.5	FPX86P0205J--
2.5	Plastic case M8/8	52 (2.072)	5 (0.197)	72 (2.835)	22 (0.866)	20	60	0.89	3.7	FPX86P0255J--
3	Plastic case M8/8	52 (2.072)	5 (0.197)	82 (3.228)	22 (0.866)	28	60	0.85	3.2	FPX86P0305J--
3.5	Plastic case M8/8	52 (2.072)	5 (0.197)	82 (3.228)	22 (0.866)	39	65	0.78	2.9	FPX86P0355J--
FPX 3500 V										
		V_{ndc} = 2000 V		V_{peak} = 2400 V		V_{rms} = 850 V		V_s = 3500 V		
2	Plastic case M8/8	62 (2.441)	5 (0.197)	72 (2.835)	22 (0.866)	23	41	1.24	6.1	FPX86X0205J-
3	Plastic case M8/8	62 (2.441)	5 (0.197)	92 (3.622)	22 (0.866)	50	62	0.92	3.9	FPX86X0305J--
3.5	Plastic case M8/8	62 (2.441)	5 (0.197)	92 (3.622)	22 (0.866)	70	72	0.83	3.4	FPX86X0355J--
4	Plastic case M8/8	62 (2.441)	5 (0.197)	92 (3.622)	22 (0.866)	85	80	0.78	3.1	FPX86X0405J--
FPX 4500 V										
		V_{ndc} = 2500 V		V_{peak} = 3200 V		V_{rms} = 1130 V		V_s = 4500 V		
1	Plastic case M8/8	62 (2.441)	5 (0.197)	72 (2.835)	22 (0.866)	15	38	1.4	6.2	FPX86Z0105J--
2	Plastic case M8/8	62 (2.441)	5 (0.197)	92 (3.622)	22 (0.866)	70	75	0.85	3.1	FPX86Z0205J--
FPX 4600 V										
		V_{ndc} = 3000 V		V_{peak} = 4000 V		V_{rms} = 1400 V		V_s = 4600 V		
0.68	Plastic case M8/8	62 (2.441)	5 (0.197)	72 (2.835)	22 (0.866)	14	35	1.59	6.2	FPX86Y0684J--
1.25	Plastic case M8/8	62 (2.441)	5 (0.197)	92 (3.622)	22 (0.866)	50	65	1	3.3	FPX86Y1254J--
1.5	Plastic case M8/10	79 (3.110)	6 (0.236)	97 (3.819)	-	32	60	1.4	8.3	FPX86Y0155J--
1.7	Plastic case M8/10	79 (3.110)	6 (0.236)	97 (3.819)	-	40	70	1.3	7.4	FPX86Y0175J--
2	Plastic case M8/10	79 (3.110)	6 (0.236)	97 (3.819)	-	56	80	1.1	6.3	FPX86Y0205J--
2.5	Plastic case M8/10	118 (4.646)	6 (0.236)	97 (3.819)	-	200	130	0.8	3.3	FPX86Y0255J--
2.7	Plastic case M8/10	118 (4.646)	6 (0.236)	97 (3.819)	-	232	140	0.7	3.2	FPX86Y0275J--
3	Plastic case M8/10	143 (5.630)	6 (0.236)	97 (3.819)	-	128	100	0.9	4.4	FPX86Y0305J--
3.5	Plastic case M8/10	143 (5.630)	6 (0.236)	97 (3.819)	-	170	110	0.8	4.2	FPX86Y0355J--
4	Plastic case M8/10	143 (5.630)	6 (0.236)	97 (3.819)	-	224	115	0.8	4.0	FPX86Y0405J--
4.5	Plastic case M8/10	163 (6.417)	6 (0.236)	97 (3.819)	-	522	120	0.6	5.0	FPX86Y0455J--
5	Plastic case M8/10	163 (6.417)	6 (0.236)	97 (3.819)	-	600	130	0.6	5.0	FPX86Y0505J--
6	Plastic case M8/10	163 (6.417)	6 (0.236)	97 (3.819)	-	729	160	0.5	5.0	FPX86Y0605J--

* Tol: +0 / -3mm for H ≥ 118mm

PROTECTION

For higher power protection devices and further information please see PPX Series in Capacitor for High Power Electronics available on AVX website: www.avxcorp.com



Medium Power Film Capacitors



FPX

PROTECTION MARKING

Logo	Nominal DC voltage in clear
Withstanding surge voltage	RMS current in clear
Capacitance and tolerance in clear	Date of manufacture (IEC coding)

DESIGN

Plastic Case M6 / 6 or M8 / 8

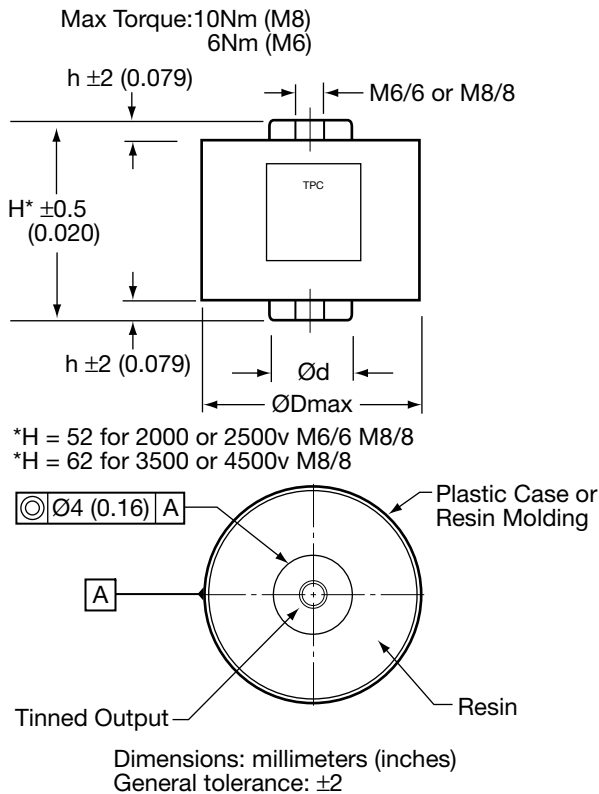

Plastic Case M8 / 10

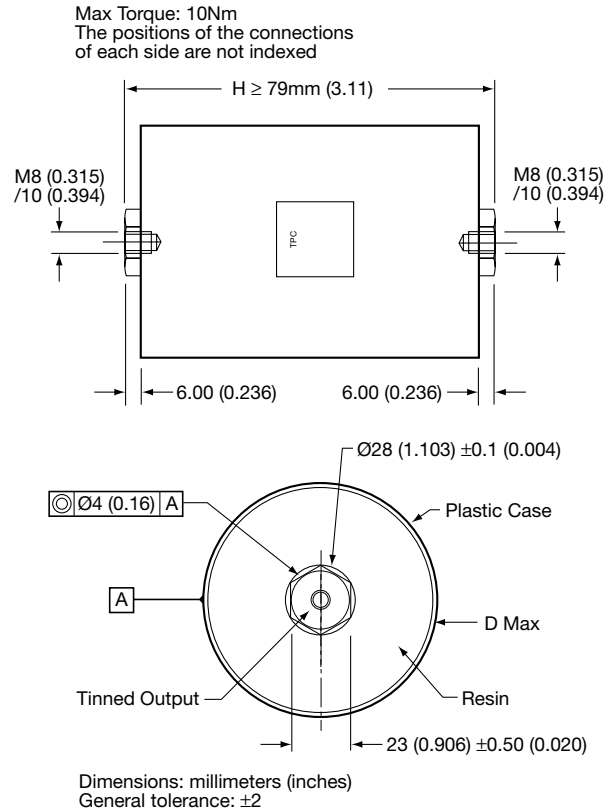

HOT SPOT TEMPERATURE CALCULATION

$$\theta_{\text{hot spot}} = \theta_{\text{terminals}} + (P_d + P_t) \times R_{\text{th}}$$

with

$$P_d \text{ (Dielectric losses)} = Q \times \text{tg} \delta_0$$

$$\Rightarrow \left[\frac{1}{2} \times C_n \times (V_{\text{peak to peak}})^2 \times f \right] \times (2 \times 10^{-4})$$

$$P_t \text{ (Thermal losses)} = R_s \times (I_{\text{rms}})^2$$

where

- C_n in Farads
- V in Volts
- I_{rms} in Amperes
- R_s in Ohms
- f in Hertz
- θ in °C
- R_{th} in °C/W

Due to the design of the capacitor and its technology, the thermal impedance between the terminations and the core of the capacitor is low, it is necessary to take care that the capacitor is never overheated by use of incorrect sized connections.

In the case where the series diodes are screwed to the capacitor, cooling of the diodes must be taken in account.

Do not use the capacitor as a heat sink.

Due to the complexity of the diode/capacitor thermal exchanges, we recommend that thermal measurements shall be made on the different components. We would be pleased to advise you on specific problems.

WORKING TEMPERATURE

(according to the power to be dissipated) -40°C to +85°C

For higher power protection devices and further information please see PPX Series in Capacitor for High Power Electronics available on AVX website: www.avxcorp.com

Medium Power Film Capacitors



FPG - General Description

PROTECTION



Metallized polypropylene dielectric capacitor with controlled self-healing.

Reinforced metallization on margins developed for high impulse currents.

Axial connections specially developed to reduce series inductance and to provide rigid mechanical mounting.

APPLICATIONS

Protection of gate turn-off thyristor (G.T.O.).

Medium frequency tuning.

PACKAGING

Cylindrical in either plastic case (preferred packaging) or a resin molding.

Outputs: threaded inserts either M6 or M8.

Filled with thermosetting resin.

ELECTRICAL CHARACTERISTICS

Capacitance range C_n	0.12 μ F to 6 μ F
Tolerance on C_n	$\pm 5\%$
Rated DC voltage $V_{n,dc}$	800 to 3000 V
Peak voltage V_{peak}	1200 to 4000 V
Allowable overvoltage V_s (for 10 s/day)	1500 to 4600 V
Nominal RMS voltage $V_{n,dc}$	500 to 1400 V
Stray inductance	≈ 10 nH
RMS current	I_{rms} max. = up to 80 A The currents shown in the tables are maximum. It is necessary to respect the thermal limits of the dielectric 85°C see "Hot spot temperature calculation"
Insulation resistance	$R_i \times C \geq 30,000$ s
Impulse current	$I^2.t$ max. given in the tables Spikes or peak currents in the capacitors may cause a deterioration of the bonding between the metallization and the connections. These bonds are capable of withstanding only a limited amount of energy for each spike. The table shows the maximum energy permitted in the form ($I^2.t$), where I is in Ampere, and t is in seconds.
Note: The formula ($I^2.t$) replaces dV/dt which is less easy to use as it is not an expression of energy ($I = C.dV/dt$). This type of capacitor has been designed to withstand high ($I^2.t$) values.	
Variation of capacitance with temperature	$\frac{\Delta C}{C} \leq \pm 2\%$ between -40 and 85°C
Climatic category	40/085/56 (IEC 68)
Test voltage between terminals @ 25°C	V_s during 10s
Test voltage between terminals and case @ 25°C	@ 4 kVrms @ 50 Hz during 1 min.

PROTECTION

For higher power protection devices and further information please see PPX Series in Capacitor for High Power Electronics available on AVX website: www.avxcorp.com

Medium Power Film Capacitors



FPG General Description / Application Notes

PROTECTION

APPLICATION NOTES

G.T.O. PROTECTION

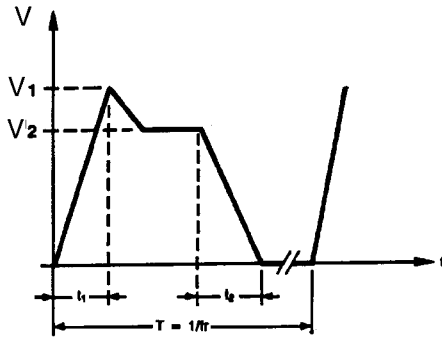

Choice of voltage: $V_1 \leq V_{peak}$
 $V_2 \leq V_{nDC}$
 Maximum overvoltage $\leq V_s$ (10 s/day)

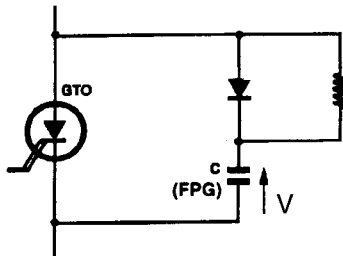

FPG: Snubber capacitor

Nominal DC voltage (V_{nDC}) and peak voltage (V_{peak}) are given in the table of values.

HOT SPOT TEMPERATURE CALCULATION

$$\theta_{hot\ spot} = \theta_{terminals} + (P_d + P_t) \times R_{th}$$

with

$$P_d \text{ (Dielectric losses)} = Q \times \tan \delta_0$$

$$\Rightarrow [\frac{1}{2} \times C_n \times (V_{peak\ to\ peak})^2 \times f] \times (2 \times 10^{-4})$$

$$P_t \text{ (Thermal losses)} = R_s \times (I_{rms})^2$$

where

- C_n in Farads
- V in Volts
- I_{rms} in Amperes
- R_s in Ohms
- f in Hertz
- θ in °C
- R_{th} in °C/W

MARKING

- Logo
- Withstanding surge voltage
- Capacitance and tolerance in clear
- Nominal DC voltage in clear
- RMS current in clear
- Date of manufacture (IEC coding)

DESIGN

Dimensions: millimeters (inches)

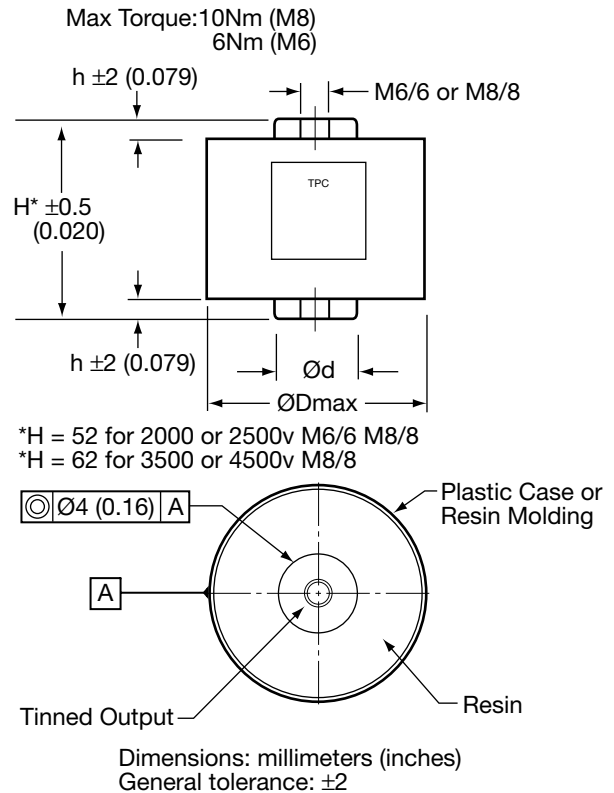

Due to the design of the capacitor and its technology, the thermal impedance between the terminations and the core of the capacitor is low, it is necessary to take care that the capacitor is never overheated by use of incorrect sized connections.

In the case where the series diodes are screwed to the capacitor, cooling of the diodes must be taken in account.

Do not use the capacitor as a heat sink.

Due to the complexity of the diode/capacitor thermal exchanges, we recommend that thermal measurements shall be made on the different components. We would be pleased to advise you on specific problems.

WORKING TEMPERATURE

(according to the power to be dissipated) -40°C to +85°C

For higher power protection devices and further information please see PPX Series in Capacitor for High Power Electronics available on AVX website: www.avxcorp.com

Medium Power Film Capacitors



FPG Table of Values

PROTECTION

Dimensions: millimeters (inches)

Cn (μ F)	Case Type	Dimensions				I ² .t max. (A ² .s)	I _{rms} max. (A)	R _s (m Ω)	R _{th} ($^{\circ}$ C/W)	Part Number	
		H* ± 0.5 (± 0.020)	h ± 2 (± 0.079)	D max.	d ± 0.5 (± 0.020)						
FPG 1500 V											
		V_ndc = 800 V				V_{peak} = 1200 V		V_{rms} = 500 V		V_s = 1500 V	
1	Resin Molding M6/6	49 (1.929)	4.2 (0.165)	40 (1.575)	19 (0.748)	2	15	2.4	14	FPG66R0105J--	
1.5	Resin Molding M6/6	49 (1.929)	4.2 (0.165)	55 (2.165)	19 (0.748)	4.6	20	1.6	10.5	FPG66R0155J--	
2	Plastic Case M8/8	52 (2.047)	5 (0.197)	60 (2.362)	22 (0.866)	8	30	1.2	6.1	FPG86R0205J--	
3	Plastic Case M8/8	52 (2.047)	5 (0.197)	72 (2.835)	22 (0.866)	18	45	0.9	4.5	FPG86R0305J--	
3.5	Plastic Case M8/8	52 (2.047)	5 (0.197)	72 (2.835)	22 (0.866)	25	50	0.85	4.5	FPG86R0355J--	
4	Plastic Case M8/8	52 (2.047)	5 (0.197)	82 (1.575)	22 (0.866)	32	60	0.75	3.5	FPG86R0405J--	
5	Plastic Case M8/8	52 (2.047)	5 (0.197)	82 (3.622)	22 (0.866)	50	70	0.65	2.5	FPG86R0505J--	
6	Resin Molding M8/8	52 (2.047)	5.7 (0.224)	92 (3.622)	28 (1.102)	73	75	0.6	2.5	FPG86R0605J--	
FPG 2000 V											
		V_ndc = 1000 V				V_{peak} = 1600 V		V_{rms} = 600 V		V_s = 2000 V	
0.5	Plastic Case M6/6	52 (2.047)	5 (0.197)	40 (1.575)	18 (0.709)	1	15	3	14	FPG66N0504J--	
1	Plastic Case M8/8	52 (2.047)	5 (0.197)	60 (2.362)	22 (0.866)	3	20	2.3	10.5	FPG86N0105J--	
1.5	Plastic Case M8/8	52 (2.047)	5 (0.197)	60 (2.362)	22 (0.866)	7	30	1.5	6.1	FPG86N0155J--	
2	Plastic Case M8/8	52 (2.047)	5 (0.197)	72 (2.835)	22 (0.866)	12.7	40	1.1	4.5	FPG86N0205J--	
2.5	Plastic Case M8/8	52 (2.047)	5 (0.197)	72 (2.835)	22 (0.866)	20	60	0.89	3.7	FPG86N0255J--	
3	Plastic Case M8/8	52 (2.047)	5 (0.197)	82 (3.228)	22 (0.866)	28	60	0.85	3.2	FPG86N0305J--	
3.5	Plastic Case M8/8	52 (2.047)	5 (0.197)	82 (3.228)	22 (0.866)	39	65	0.78	2.9	FPG86N0355J--	
4	Resin Molding M8/8	52 (2.047)	5.7 (0.224)	92 (3.622)	28 (1.102)	50	70	0.7	2.5	FPG86N0405J--	
FPG 2500 V											
		V_ndc = 1300 V				V_{peak} = 2000 V		V_{rms} = 700 V		V_s = 2500 V	
0.47	Resin Molding M6/6	59 (2.323)	4.2 (0.165)	40 (1.575)	19 (0.748)	0.7	15	6	25	FPG66P0474J--	
1	Resin Molding M6/6	59 (2.323)	4.2 (0.165)	55 (2.165)	19 (0.748)	2	18	3	13	FPG66P0105J--	
1.5	Resin Molding M8/8	59 (2.323)	4.2 (0.165)	60 (2.362)	19 (0.748)	4.5	25	2	10	FPG66P0155J--	
2	Plastic Case M8/8	62 (2.441)	5 (0.197)	72 (2.835)	22 (0.866)	8	35	1.5	6.5	FPG86P0205J--	
2.5	Plastic Case M8/8	62 (2.441)	5 (0.197)	72 (2.835)	22 (0.866)	12.5	40	1.3	4.8	FPG86P0255J--	
3	Resin Molding M8/8	62 (2.441)	5.7 (0.224)	82 (3.228)	28 (1.102)	18	50	1.15	4.4	FPG86P0305J--	
4	Plastic Case M8/8	62 (2.441)	5 (0.197)	92 (3.622)	22 (0.866)	32	65	0.95	3.4	FPG86P0405J--	

 = Preferred standard values

PROTECTION

For higher power protection devices and further information please see PPX Series in Capacitor for High Power Electronics available on AVX website: www.avxcorp.com



Medium Power Film Capacitors



FPG Table of Values

PROTECTION

Dimensions: millimeters (inches)

Cn (µF)	Case Type	Dimensions				I ² t max. (A ² .s)	I _{rms} max. (A)	R _s (mΩ)	R _{th} (°C/W)	References
		H* ±0.5 (±0.020)	h ±2 (±0.079)	D max.	d ±0.5 (±0.020)					
FPG 2600 V										
		V_ndc = 1750 V			V_{peak} = 2000 V		V_{rms} = 800 V		V_s = 2600 V	
0.47	Resin Molding M6/6	59 (2.323)	4.2 (0.165)	40 (1.575)	19 (0.748)	1.4	12	4.04	28	FPG66W0474J--
1	Resin Molding M6/6	59 (2.323)	4.2 (0.165)	55 (2.165)	19 (0.748)	5.7	21	2.17	10.9	FPG66W0105J--
1.5	Resin Molding M6/6	59 (2.323)	4.2 (0.165)	60 (2.362)	19 (0.748)	12.9	31	1.55	7.7	FPG66W0155J--
2	Plastic Case M8/8	62 (2.441)	5 (0.197)	72 (2.835)	22 (0.866)	23	41	1.24	6.1	FPG86W0205J--
2.5	Resin Molding M8/8	62 (2.441)	5.7 (0.224)	82 (3.228)	28 (1.102)	36	51	1.05	4.5	FPG86W0255J--
3	Plastic Case M8/8	62 (2.441)	5 (0.197)	92 (3.622)	22 (0.866)	50	62	0.92	3.9	FPG86W0305J--
3.5	Plastic Case M8/8	62 (2.441)	5 (0.197)	92 (3.622)	22 (0.866)	70	72	0.83	3.4	FPG86W0355J--
3.9	Plastic Case M8/8	62 (2.441)	5 (0.197)	92 (3.622)	22 (0.866)	85	80	0.78	3.1	FPG86W0395J--
FPG 3500 V										
		V_ndc = 2000 V			V_{peak} = 2400 V		V_{rms} = 1000 V		V_s = 3500 V	
0.33	Resin Molding M6/6	59 (2.323)	4.2 (0.165)	40 (1.575)	19 (0.748)	2	15	2.5	28	FPG66X0334J--
0.5	Resin Molding M6/6	59 (2.323)	4.2 (0.165)	55 (2.165)	19 (0.748)	5	19	2.5	11.2	FPG66X0504J--
1	Plastic Case M8/8	62 (2.441)	5 (0.197)	72 (2.835)	22 (0.866)	15	38	1.4	6.2	FPG86X0105J--
1.5	Resin Molding M8/8	62 (2.441)	5.7 (0.224)	82 (3.228)	28 (1.102)	40	56	1.03	3.9	FPG86X0155J--
2	Plastic Case M8/8	62 (2.441)	5 (0.197)	92 (3.622)	22 (0.866)	70	75	0.85	3.1	FPG86X0205J--
FPG 4500 V										
		V_ndc = 2500 V			V_{peak} = 3200 V		V_{rms} = 1200 V		V_s = 4500 V	
0.22	Resin Molding M6/6	59 (2.323)	4.2 (0.165)	40 (1.575)	19 (0.748)	1.5	15	3.8	25	FPG66Z0224J--
0.47	Resin Molding M6/6	59 (2.323)	4.2 (0.165)	60 (2.362)	19 (0.748)	7	24	2.16	8.5	FPG66Z0474J--
0.68	Plastic Case M8/8	62 (2.441)	5 (0.197)	72 (2.835)	22 (0.866)	14	35	1.59	6.2	FPG86Z0684J--
1	Resin Molding M8/8	62 (2.441)	5.7 (0.224)	82 (3.228)	28 (1.102)	30	52	1.18	4	FPG86Z0105J--
1.25	Plastic Case M8/8	62 (2.441)	5 (0.197)	92 (3.622)	22 (0.866)	50	65	1	3.3	FPG86Z1254J--
FPG 4600 V										
		V_ndc = 3000 V			V_{peak} = 4000 V		V_{rms} = 1400 V		V_s = 4600 V	
0.12	Resin Molding M6/6	59 (2.323)	4.2 (0.165)	40 (1.575)	19 (0.748)	0.8	15	6	28	FPG66Y0124J--
0.22	Resin Molding M6/6	59 (2.323)	4.2 (0.165)	60 (2.362)	19 (0.748)	3	20	3.48	11	FPG66Y0224J--
0.33	Plastic Case M8/8	62 (2.441)	5 (0.197)	72 (2.835)	22 (0.866)	6.8	25	2.42	7.7	FPG86Y0334J--
0.47	Resin Molding M8/8	62 (2.441)	5.7 (0.224)	82 (3.228)	28 (1.102)	13.8	35	1.79	5.2	FPG86Y0474J--
0.60	Plastic Case M8/8	62 (2.441)	5 (0.197)	92 (3.622)	22 (0.866)	22	45	1.47	4.2	FPG86Y0604J--

 = Preferred standard values

For higher power protection devices and further information please see PPX Series in Capacitor for High Power Electronics available on AVX website: www.avxcorp.com

Medium Power Film Capacitors



FAV General Description

TUNING

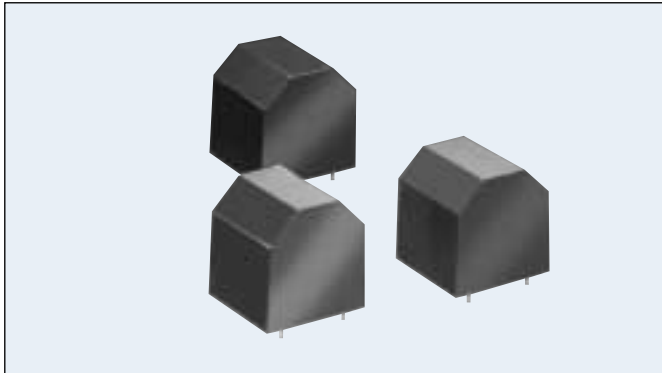

APPLICATIONS

High reactive energy tuning for converters.
Protection of semi-conductors.

TECHNOLOGY

Metallized polypropylene film and metal foil.
Dry capacitor.

PACKAGING

Rectangular resin case.
4 leads 1.2 x 0.8mm for printed circuit board mounting.
Self-extinguishing plastic case (V0 = in accordance with UL 94) filled thermosetting resin.
Self-extinguishing thermosetting resin (V0 = in accordance with UL 94; M2F1 = in accordance with NF F 16-101).
(Note that FFV3 and FAV3 are in the same packaging.)

ELECTRICAL CHARACTERISTICS

Climatic category	40/085/56 (IEC 68)
Working temperature	hot spot temperature: -40 to +85°C
Hot spot temperature	≤85°C (must be calculated: see below)
Capacitance range C _n	80 to 1200nF
Tolerance	±10%
Rated AC voltage	V _{n,rms} = 300 to 650 V
Rated DC voltage	V _{n,dc} = 600 to 2000 V
Maximum rms current	I _{rms} max = 10 to 40 Arms
Maximum reactive power	Q max = 7 to 14 kvar
Stray inductance	15 nH
Test voltage between terminals	1.5 x V _{n,dc} 10s
Withstanding voltage between terminals and case	3000 Vrms 60s

STANDARDS

IEC 1071-1: IEC 1071-2: Power electronic capacitors

IEC 68-1: Environmental testing

IEC 77: Rules for electric traction equipment

UL 94: Fire requirements

NF F 16-101

NF F 16-102: Fire and smoke requirements

HOT SPOT TEMPERATURE CALCULATION

$$\theta_{\text{hot spot}} = \theta_{\text{case}} + (P_d + P_t) \times R_{\text{th}}$$

with P_d (Dielectric losses) = $Q \times \text{tg}\delta_0$
 $\Rightarrow [\frac{1}{2} \times C \times (V_{\text{peak to peak}})^2 \times \text{fr}] \times 2.10^{-4}$
 \Rightarrow Protections applications
 $\Rightarrow (V^2 \times C \times 2 \pi \text{Fr}) \times 2.10^{-4}$
 \Rightarrow Tuning applications
 P_c (Joule losses) = $R_s \times (I_{\text{rms}})^2$

where

Q in Var R_s in Ohm R_{th} in °C/W

LIFETIME EXPECTANCY

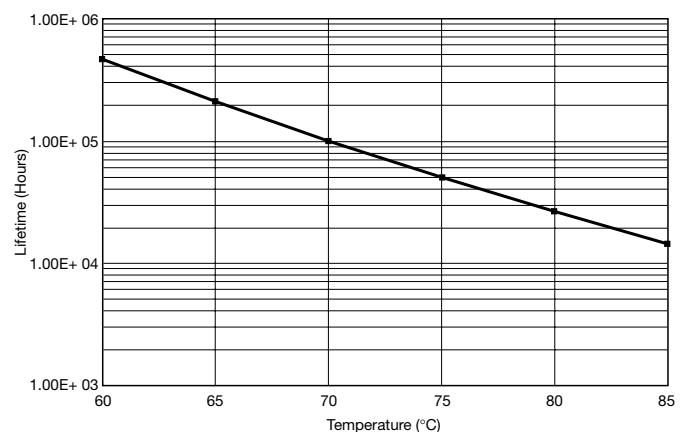

Medium Power Film Capacitors



FAV

TUNING

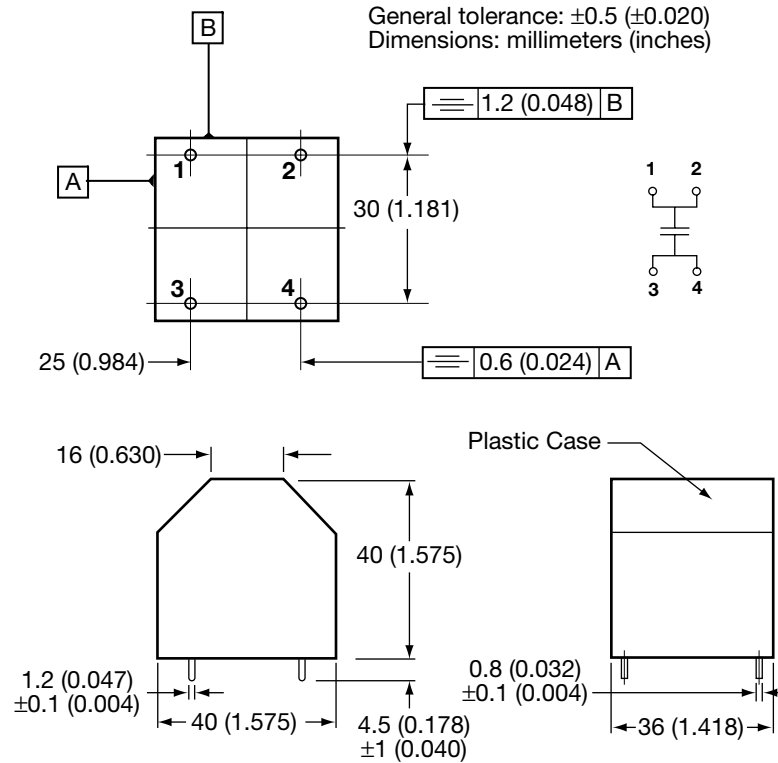

Cn (nF)	I rms max (A)	Q max (kV)	Rs (mΩ)	Ls (nH)	Rth (°C/W)	Part Number
V_{Ndc} 600 V		V_{rms}: 300 V				
1200	40	12	0.85	5	4	FAV36K0125K--
1000	32	10	1	5	4.1	FAV36K0105K--
V_{Ndc} 800 V		V_{rms}: 400 V				
800	35	14	0.9	5	4	FAV36B0804K--
620	27	11	1.1	5	4.1	FAV36B0624K--
V_{Ndc} 1000 V		V_{rms}: 450 V				
560	30	14	1	5	4	FAV36L0564K--
470	25	12	1.2	5	4.1	FAV36L0474K--
V_{Ndc} 1200 V		V_{rms}: 500 V				
330	21	11	1.4	5	4.2	FAV36U0334K--
270	17	9	1.7	5	4.4	FAV36U0274K--
V_{Ndc} 1500 V		V_{rms}: 600 V				
180	16	10	1.7	5	4.4	FAV36R0184K--
150	13	8	2	5	4.5	FAV36R0154K--
V_{Ndc} 2000 V		V_{rms}: 650 V				
120	15	10	1.92.2	5	4.6	FAV36N0124K--
100	12	8	2.8	5	4.9	FAV36N0104K--
80	10	7	1.5	5	5.2	FAV36N0803K--

TUNING

TUNING

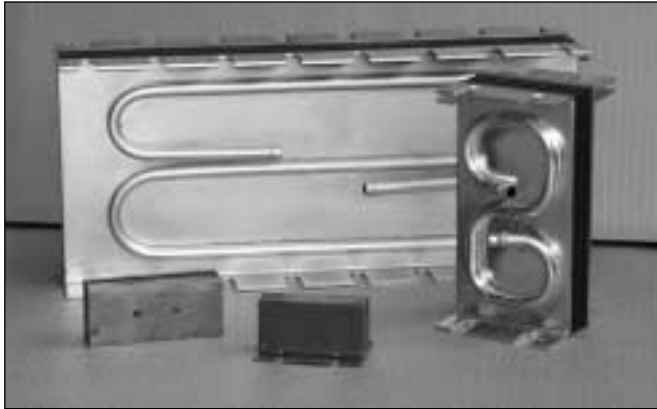

The FAI series uses metallized polypropylene dielectric specifically designed for very high reactive power.

The FAI's special design gives to this series a very low level of stray inductance.

APPLICATIONS

These capacitors have been designed principally for:
low and medium frequency applications
(10 kHz to 500 kHz)

ELECTRICAL CHARACTERISTICS

Capacitance range C_n	110nF to 60 μ F
Tolerance	$\pm 10\%$
Rated AC voltage	200 to 650 Vrms
Series parasitic inductance	< 5 nH
Test voltage between terminals @ 25°C	1.2 Vrms 50/60 Hz 10s

MAXIMUM WORKING TEMPERATURE (HOT SPOT)

+85°C: Hot spot temperature must be calculated as function of power dissipation.

HOT SPOT (THERMAL) CALCULATION

You can calculate the maximum operating (hot spot) temperature of this capacitor in the following manner:

Polypropylene has a constant loss factor ($\text{tg}\delta_0$) of 2×10^{-4} irrespective of temperature and frequency (up to 1 MHz).

The loss factor of the capacitor is made up of the sum of two components. The first represents electrical losses ($\text{tg}\delta_0 = 2 \cdot 10^{-4}$) and the second represents Joule effect in the connection and foils: $R_s \cdot C \cdot 2\pi F$.

For all applications, the temperature in the hot spot capacitor must be lower than 85°C.

Heating calculation of hot spot capacitor: FAI1 FAI2 FAI3

$$\theta_{\text{hot spot}} = \theta_{\text{terminals}} + (\text{tg}\delta_0 \cdot Q + R_s \cdot (I_{\text{rms}})^2) \cdot R_{\text{th}}$$

Heating calculation of hot spot capacitor: FAI6

$$\theta_{\text{hot spot}} = \theta_{\text{water}} + (\text{tg}\delta_0 \cdot Q + R_s \cdot (I_{\text{rms}})^2) \cdot R_{\text{th}}$$

With: $\text{tg}\delta_0 = 2 \cdot 10^{-4}$

Q in Var

R_s in Ohms

I_{rms} in Amperes

R_{th} in °C/W (water flow = 10 dm³/minute)

Note: The life time depends of hot spot temperature, see following curve.

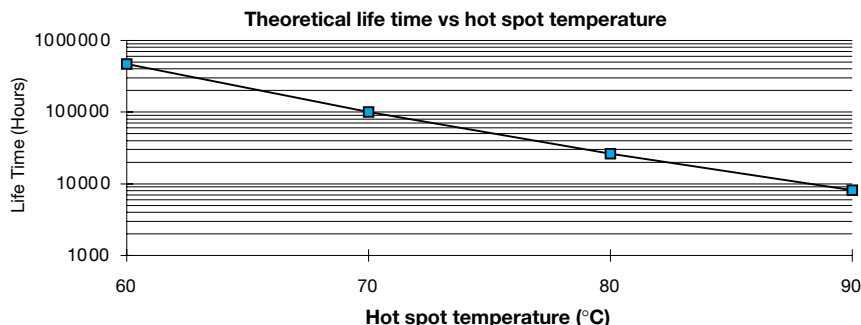

Medium Power Film Capacitors



FAI

TUNING FAI1 VERSION

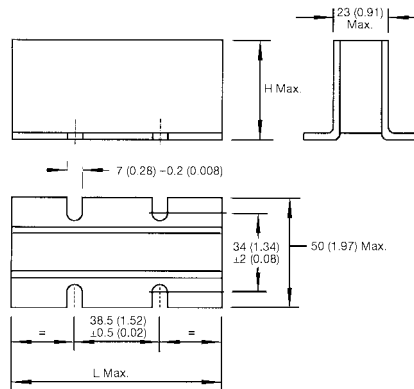

Dimensions: millimeters (inches)

C (nF)	I _{rms} max (A)	V _{rms} max (V)	Q max kVARS	R _s (mΩ)	R _{th} (°C/W)	L max	H max	Part Number
110	180	500	100	$8 \times 10^{-4} \times \sqrt{F} + 0.19$	0.86	55 (2.165)	35 (1.378)	FAI16J0114K--
210	300	500	150	$5 \times 10^{-4} \times \sqrt{F} + 0.12$	0.67	75 (2.953)	40 (1.575)	FAI16J0214K--
330	350	500	175	$5 \times 10^{-4} \times \sqrt{F} + 0.15$	0.54	75 (2.953)	40 (1.575)	FAI16J0334K--
510	500	500	250	$4 \times 10^{-4} \times \sqrt{F} + 0.08$	0.49	95 (3.740)	45 (1.772)	FAI16J0514K--

With F in Hz

FAI2 VERSION

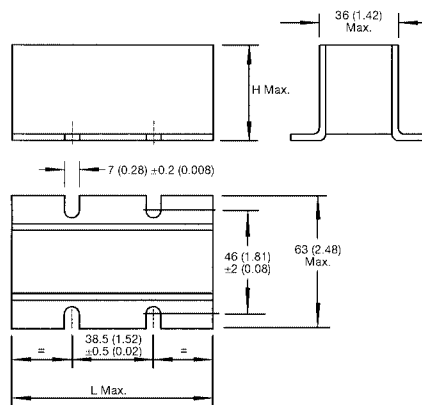

Dimensions: millimeters (inches)

C (nF)	I _{rms} max (A)	V _{rms} max (V)	Q max kVARS	R _s (mΩ)	R _{th} (°C/W)	L max	H max	Part Number
660	300	500	180	$5 \times 10^{-4} \times \sqrt{F} + 0.25$	0.6	75 (2.953)	40 (1.575)	FAI26J0664K--
1200	400	500	200	$5 \times 10^{-4} \times \sqrt{F} + 0.20$	0.56	75 (2.953)	40 (1.575)	FAI26J0125K--
2400	500	350	175	$5 \times 10^{-4} \times \sqrt{F} + 0.17$	0.55	75 (2.953)	40 (1.575)	FAI26I0245K--

With F in Hz

FAI3 VERSION

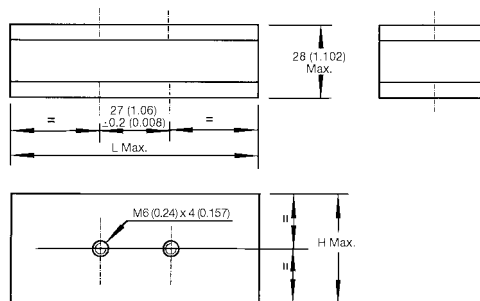

Dimensions: millimeters (inches)

C (nF)	I _{rms} max (A)	V _{rms} max (V)	Q max kVARS	R _s (mΩ)	R _{th} (°C/W)	L max	H max	Part Number
110	180	500	100	0.3	0.82	55 (2.165)	35 (1.378)	FAI36J0114K--
330	350	500	175	0.15	0.55	75 (2.953)	37 (1.457)	FAI36J0334K--
510	500	500	250	0.1	0.3	95 (3.740)	42 (1.654)	FAI36J0514K--
660	600	500	300	0.1	0.24	95 (3.740)	42 (1.654)	FAI36J0664K--

Medium Power Film Capacitors



FAI

TUNING

110 nF 500 Vrms
FAI16J0114K--
FAI36J0114K--

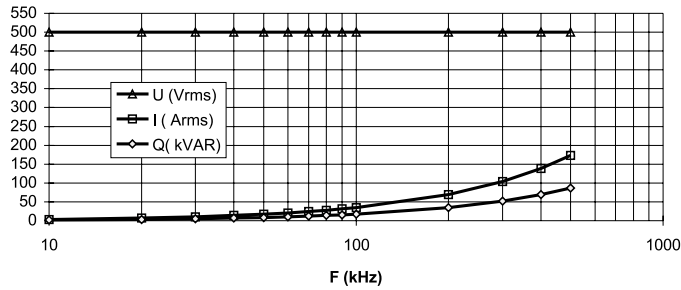

660 nF 500 Vrms
FAI16J0664K--
FAI36J0664K--

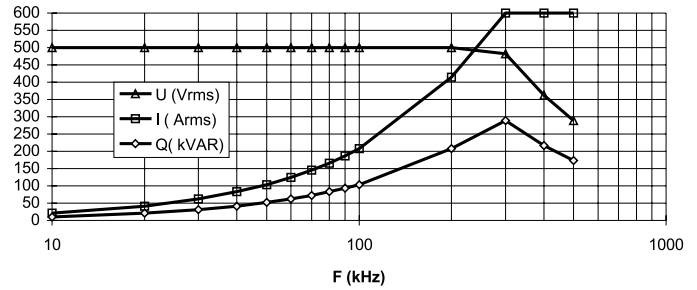

210 nF 500 Vrms
FAI16J0214K--

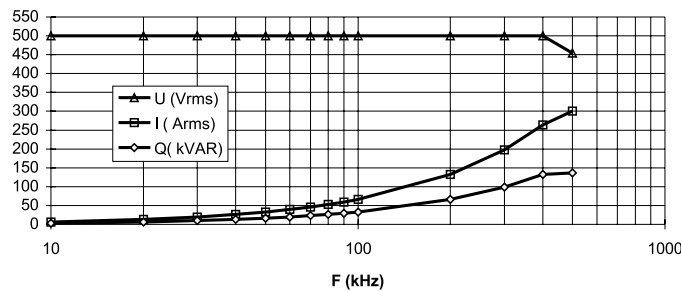

660 nF 500 Vrms
FAI26J0664K--

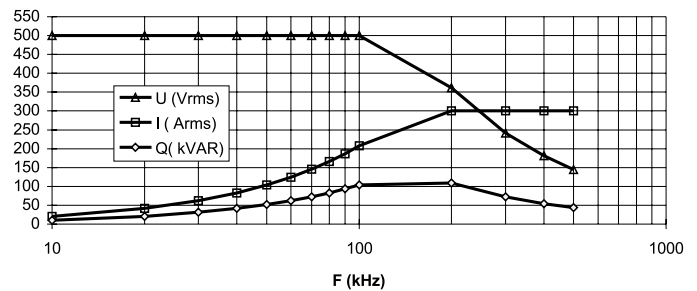

330 nF 500 Vrms
FAI16J0334K--
FAI36J0334K--

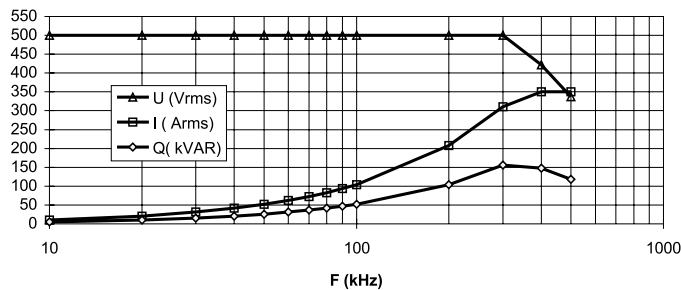

1200 nF 500 Vrms
FAI26J0125K--

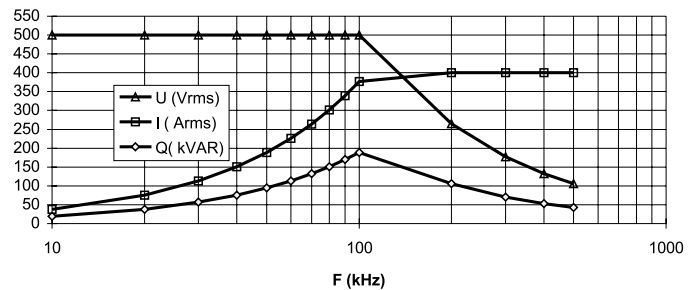

510 nF 500 Vrms
FAI16J0514K--
FAI36J0514K--

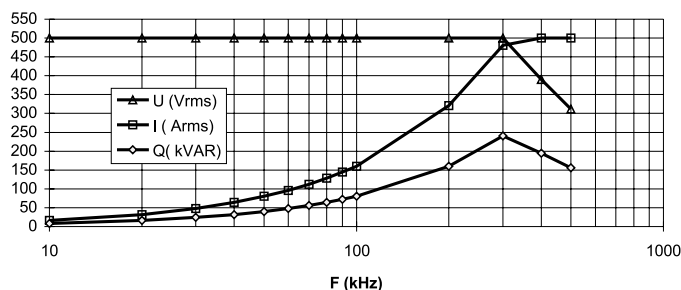

2400 nF 350 Vrms
FAI26I0245K--

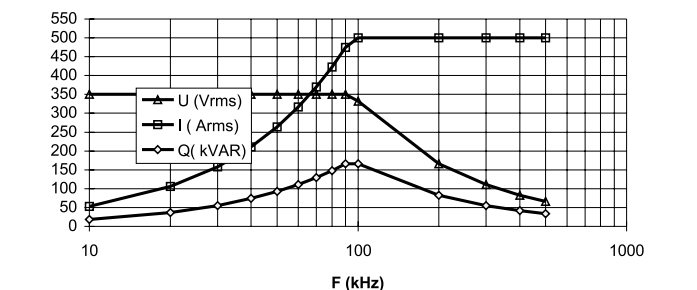

TUNING

Medium Power Film Capacitors



FAI

TUNING

FAI6

Dimensions: millimeters (inches)

Width	Vrms max (V)	C (μF)	Qmax (kVAR)	Irms max (A)	Rs (mΩ)	Rth (°C/W)	Part Number
90 (3.543)	200	15	160	800	$5.10^{-4} \times \sqrt{f(\text{Hz})} + 0.025$	0.104	FAI66F0156K--
	300	12	240	800	$5.10^{-4} \times \sqrt{f(\text{Hz})} + 0.03$	0.104	FAI66H0126K--
	400	7	320	800	$5.10^{-4} \times \sqrt{f(\text{Hz})} + 0.035$	0.114	FAI66I0705K--
	500	5	320	640	$5.10^{-4} \times \sqrt{f(\text{Hz})} + 0.04$	0.114	FAI66J0505K--
	600	3.5	320	530	$5.10^{-4} \times \sqrt{f(\text{Hz})} + 0.05$	0.124	FAI66K0355K--
	650	1.5	320	490	$5.10^{-4} \times \sqrt{f(\text{Hz})} + 0.07$	0.134	FAI66A0155K--
190 (7.480)	200	30	240	1200	$2.5.10^{-4} \times \sqrt{f(\text{Hz})} + 0.0125$	0.079	FAI66F0306K--
	300	24	360	1200	$2.5.10^{-4} \times \sqrt{f(\text{Hz})} + 0.015$	0.079	FAI66H0246K--
	400	14	480	1200	$2.5.10^{-4} \times \sqrt{f(\text{Hz})} + 0.0175$	0.084	FAI66I0146K--
	500	10	600	1200	$2.5.10^{-4} \times \sqrt{f(\text{Hz})} + 0.02$	0.084	FAI66J0106K--
	600	7	640	1070	$2.5.10^{-4} \times \sqrt{f(\text{Hz})} + 0.025$	0.089	FAI66K0705K--
	650	3	640	985	$2.5.10^{-4} \times \sqrt{f(\text{Hz})} + 0.035$	0.094	FAI66A0305K--
290 (11.417)	200	45	320	1600	$2.10^{-4} \times \sqrt{f(\text{Hz})} + 0.0083$	0.072	FAI66F0456K--
	300	36	480	1600	$2.10^{-4} \times \sqrt{f(\text{Hz})} + 0.01$	0.072	FAI66H0366K--
	400	21	640	1600	$2.10^{-4} \times \sqrt{f(\text{Hz})} + 0.0117$	0.075	FAI66I0216K--
	500	15	800	1600	$2.10^{-4} \times \sqrt{f(\text{Hz})} + 0.0133$	0.075	FAI66J0156K--
	600	10.5	960	1600	$2.10^{-4} \times \sqrt{f(\text{Hz})} + 0.0167$	0.078	FAI66K1055K--
	650	4.5	960	1480	$2.10^{-4} \times \sqrt{f(\text{Hz})} + 0.0233$	0.082	FAI66A0455K--
390 (15.354)	200	60	400	2000	$1.5.10^{-4} \times \sqrt{f(\text{Hz})} + 0.00625$	0.067	FAI66F0606K--
	300	48	600	2000	$1.5.10^{-4} \times \sqrt{f(\text{Hz})} + 0.0075$	0.067	FAI66H0486K--
	400	28	800	2000	$1.5.10^{-4} \times \sqrt{f(\text{Hz})} + 0.00875$	0.070	FAI66I0286K--
	500	20	1000	2000	$1.5.10^{-4} \times \sqrt{f(\text{Hz})} + 0.01$	0.070	FAI66J0206K--
	600	14	1200	2000	$1.5.10^{-4} \times \sqrt{f(\text{Hz})} + 0.0125$	0.072	FAI66K0146K--
	650	6	1280	1970	$1.5.10^{-4} \times \sqrt{f(\text{Hz})} + 0.0175$	0.075	FAI66A0605K--

TUNING

Medium Power Film Capacitors



FAI

TUNING

Dimensions: millimeters (inches)

FAI6 WIDTH: 90 (3.543)

FAI6 WIDTH: 290 (11.417)

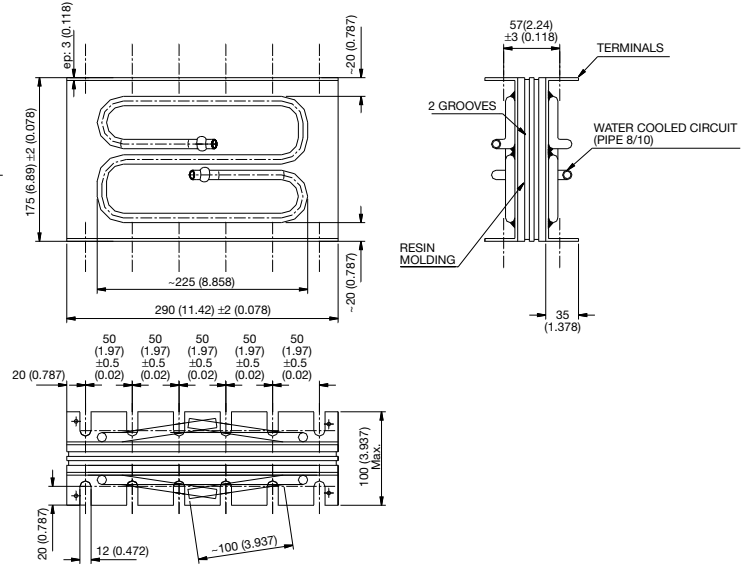
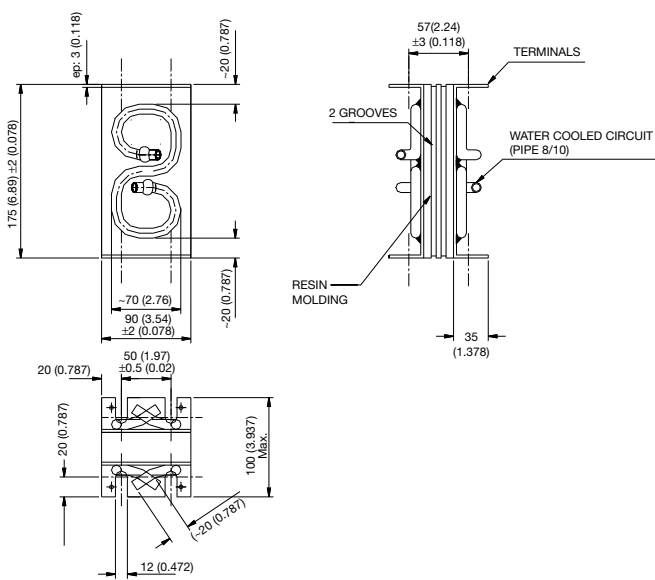

FAI6 WIDTH: 190 (7.480)

FAI6 WIDTH: 390 (15.354)

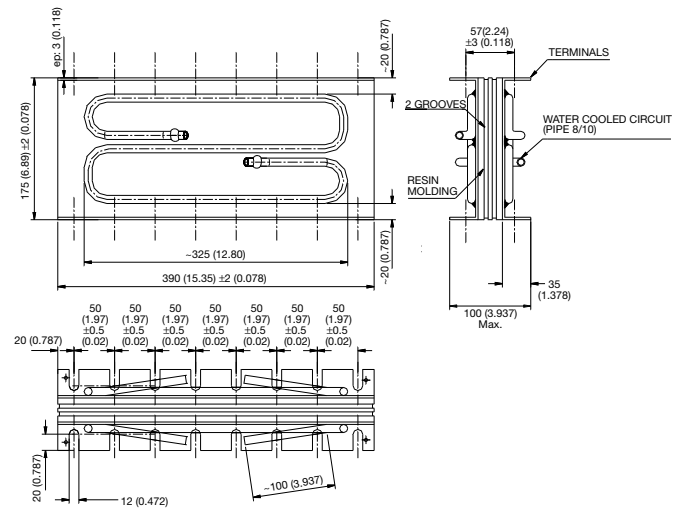
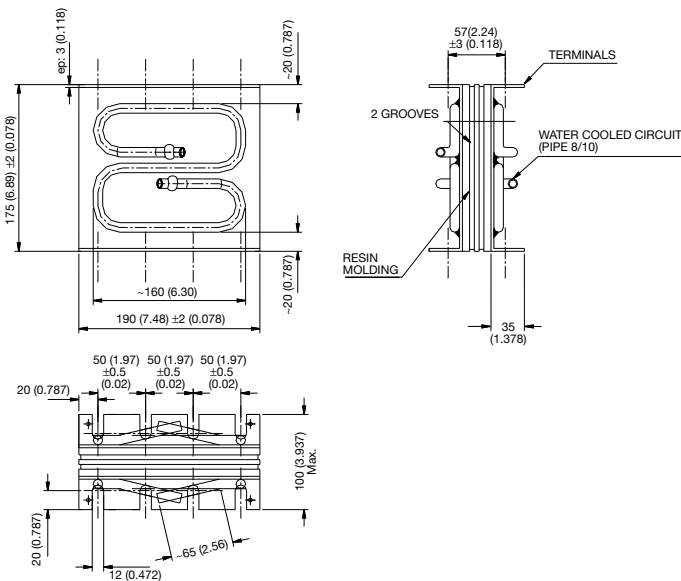

TUNING

Medium Power Film Capacitors



FAI

TUNING

15 μ F 200 Vrms Width 90 mm
FAI66F0156K--

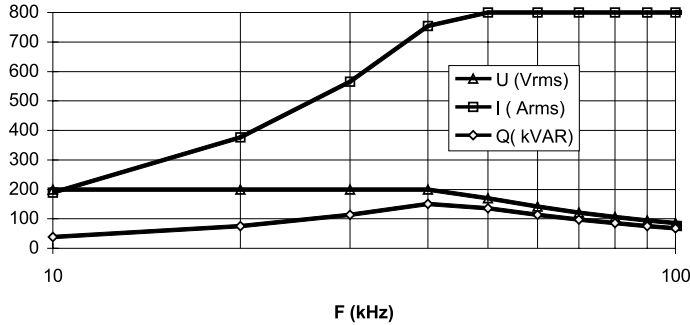

12 μ F 300 Vrms Width 90 mm
FAI66H0126K--

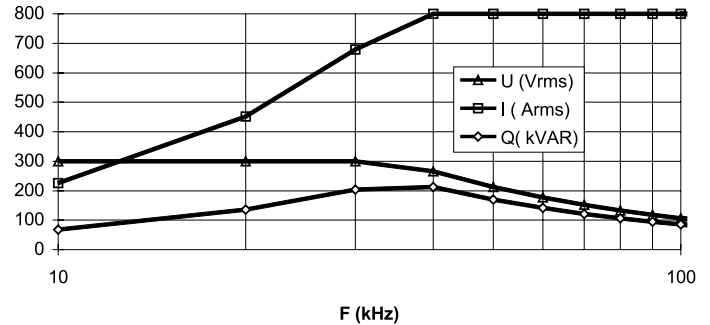

30 μ F 200 Vrms Width 190 mm
FAI66F0306K--

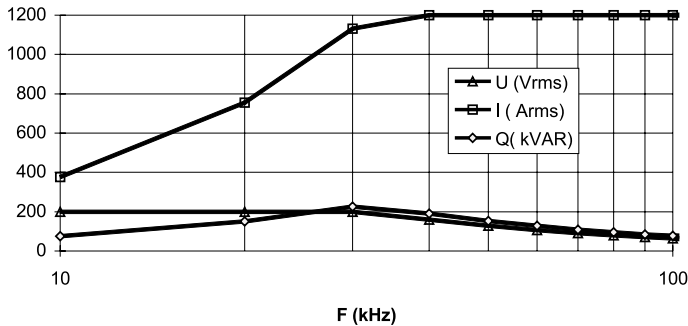

24 μ F 300 Vrms Width 190 mm
FAI66H0246K--

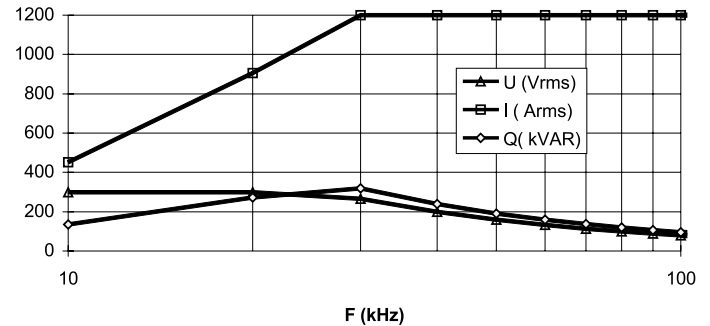

45 μ F 200 Vrms Width 290 mm
FAI66F0456K--

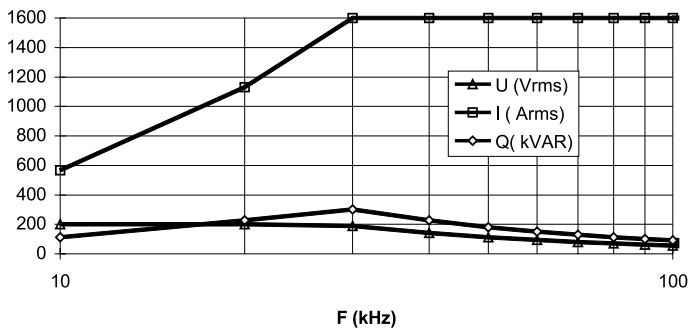

36 μ F 300 Vrms Width 290 mm
FAI66H0366K--

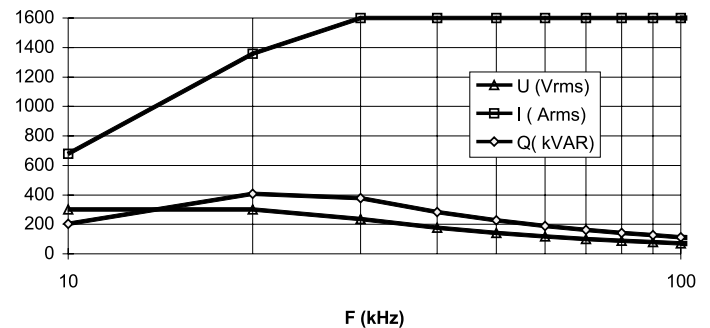

60 μ F 200 Vrms Width 390 mm
FAI66F0606K--

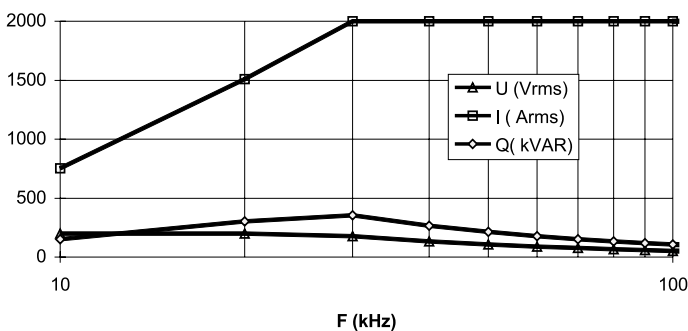

48 μ F 300 Vrms Width 390 mm
FAI66H0486K--

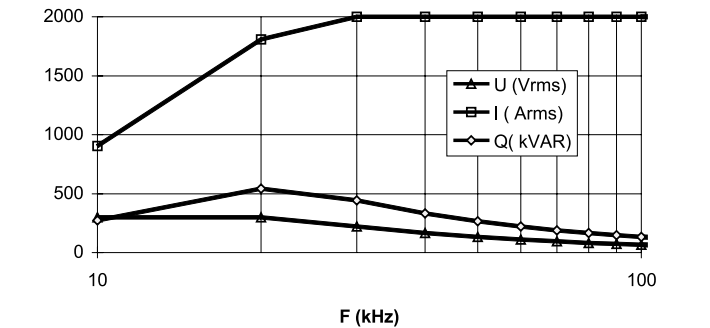

TUNING

Medium Power Film Capacitors



FAI

TUNING

7 μ F 400 Vrms Width 90 mm
FAI66I0705K--

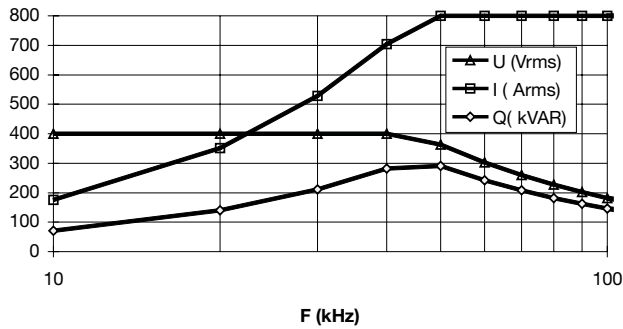

5 μ F 500 Vrms Width 90 mm
FAI66J0505K--

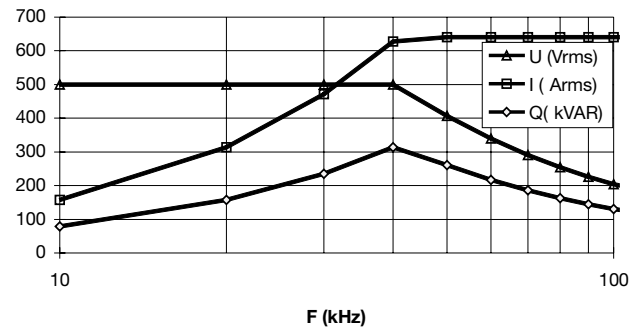

14 μ F 400 Vrms Width 190 mm
FAI66I0146K--

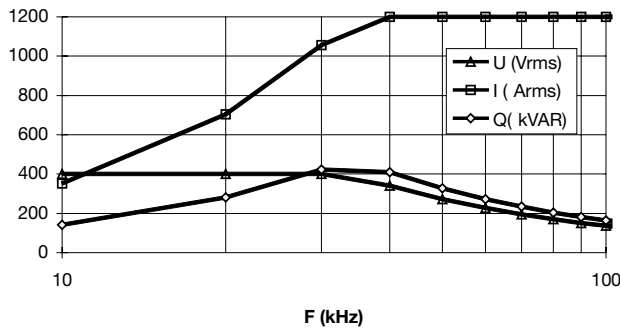

10 μ F 500 Vrms Width 190 mm
FAI66J0106K--

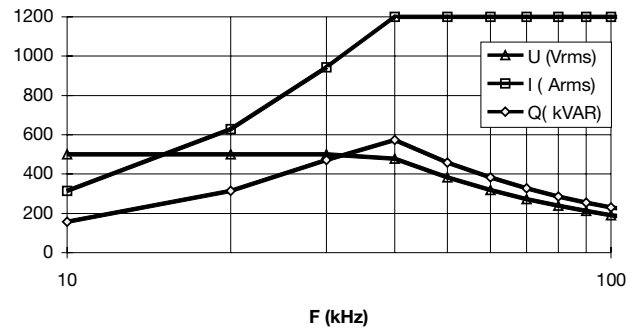

21 μ F 400 Vrms Width 290 mm
FAI66I0216K--

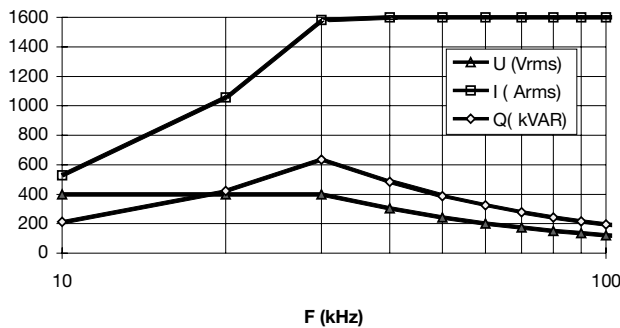

15 μ F 500 Vrms Width 290 mm
FAI66J0156K--

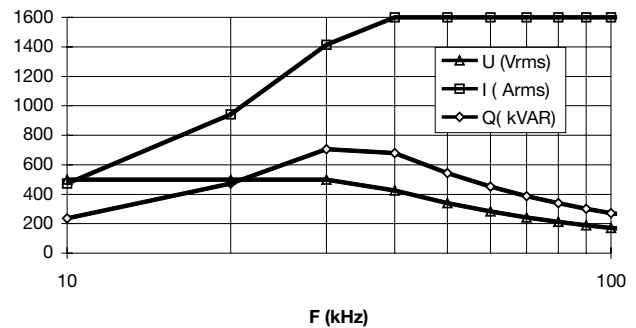

28 μ F 400 Vrms Width 390 mm
FAI66I0286K--

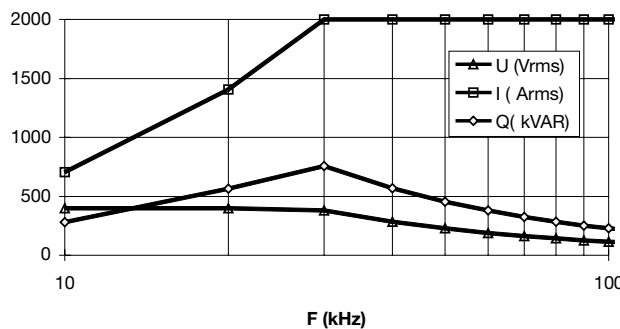

20 μ F 500 Vrms Width 390 mm
FAI66J0206K--

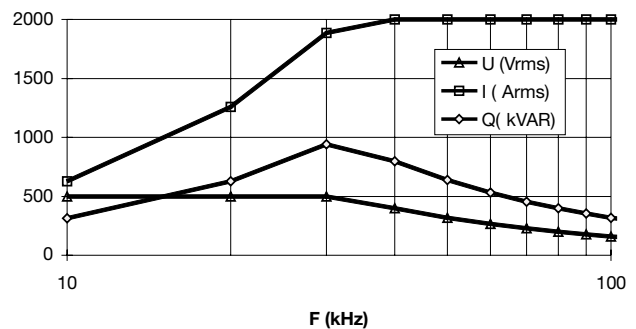

TUNING

Medium Power Film Capacitors



FAI

TUNING

3.5 μ F 600 Vrms Width 90 mm
FAI66K0355K--

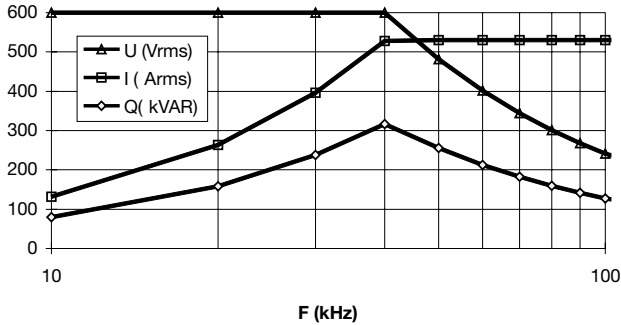

1.5 μ F 650 Vrms Width 90 mm
FAI66A0155K--

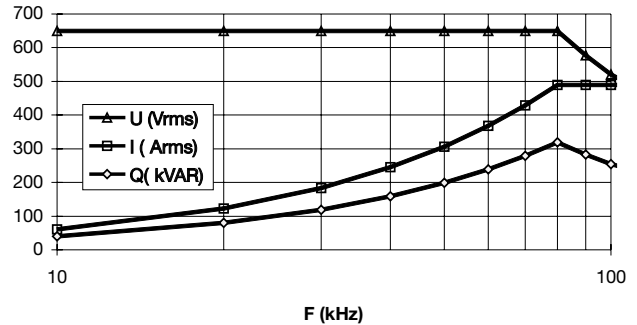

7 μ F 600 Vrms Width 190 mm
FAI66K0705K--

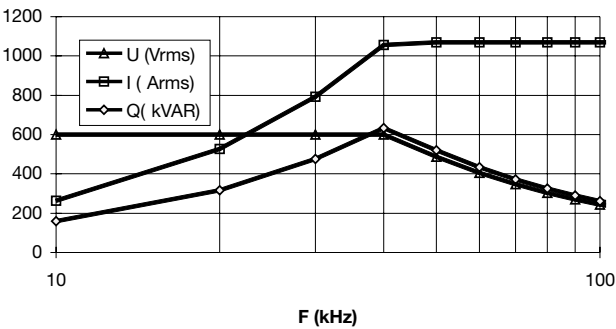

3 μ F 650 Vrms Width 190 mm
FAI66A0305K--

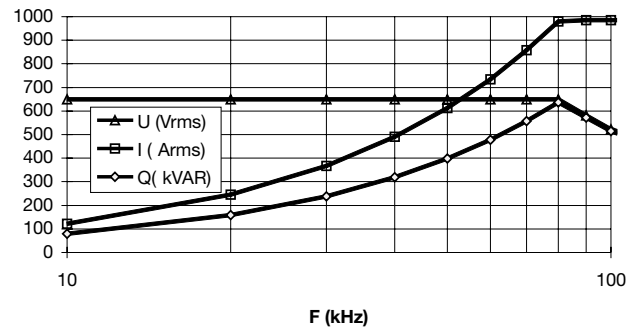

10.5 μ F 600 Vrms Width 290 mm
FAI66K1055K--

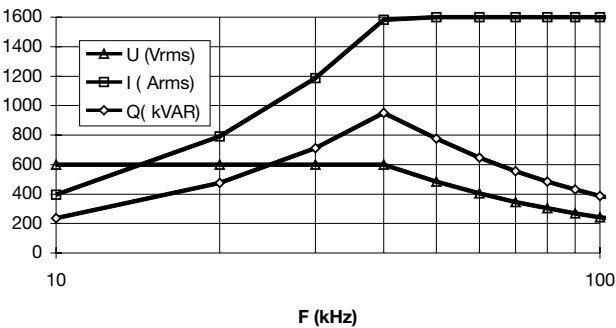

4.5 μ F 650 Vrms Width 290 mm
FAI66A0455K--

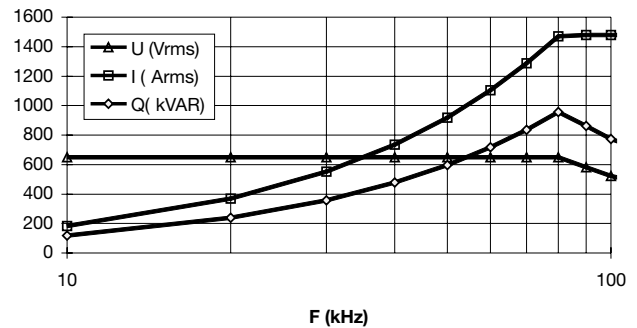

14 μ F 600 Vrms Width 390 mm
FAI66K0146K--

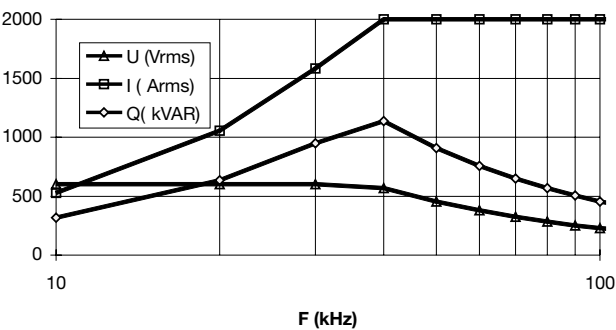

6 μ F 650 Vrms Width 390 mm
FAI66A0605K--

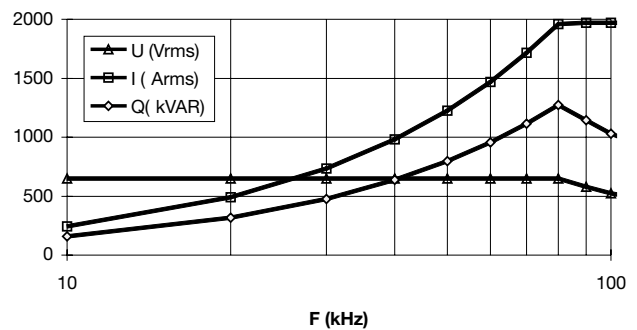

TUNING

Medium Power Film Capacitors



Worksheet for Custom Requirements

Company _____
Name _____ Phone Number _____
Department _____ Fax Number _____
Address _____ E-mail _____

ELECTRICAL CHARACTERISTICS

Applications	DC Filtering	Protection*	Tuning
Capacitance (C)	_____ uF	_____ uF	_____ uF
Tolerance (%)	_____ %	_____ %	_____ %
Operating Voltage	_____ Vdc	_____ Vpk / _____ Vdc*	_____ Vrms
Ripple Voltage	_____ Vr		
Working Frequency (f)	_____ Hz		_____ Hz
Operating Current (Irms)	_____ Irms	_____ Irms	_____ Irms
Maximum Current (Imax)	_____ Imax		
Maximum Peak Current (Ipeak)	_____ Ipk	_____ Ipk	
Maximum Inductance (Ls)	_____ nH	_____ nH	_____ nH
Test voltage between terminals	_____ V	_____ V	_____ V
Maximum surge voltages (MSV)	_____ V	_____ V	
MSV duration / frequency	_____ s _____ / year	_____ s _____ / year	

* - Due to the particularities of varying waveforms in such applications more information on the exact nature of waveforms is generally required for a full analysis.

THERMAL CHARACTERISTICS

Storage temp. ____ min ____ avg ____ max (C) Operating Temp ____ min ____ avg ____ max (C)
Cooling Method (check one) - Natural Convection ____ Forced Air ____ Water ____
Dimensions / shape (please indicate in. / mm.) _____
and type of bushings _____ Environment _____
Operating Position: (circle one) (vertical / horizontal / inclined / other _____)

Other information / drawing / block diagram of circuit:

Please send this to your local AVX representative.

USA

AVX Myrtle Beach, SC Corporate Offices

Tel: 843-448-9411
FAX: 843-626-5186

AVX Northwest, WA

Tel: 360-669-8746
FAX: 360-699-8751

AVX North Central, IN

Tel: 317-848-7153
FAX: 317-844-9314

AVX Northeast, MA

Tel: 508-485-8114
FAX: 508-485-8471

AVX Mid-Pacific, CA

Tel: 408-436-5400
FAX: 408-437-1500

AVX Southwest, AZ

Tel: 480-539-1496
FAX: 480-539-1501

AVX South Central, TX

Tel: 972-669-1223
FAX: 972-669-2090

AVX Southeast, NC

Tel: 919-878-6357
FAX: 919-878-6462

AVX Canada

Tel: 905-564-8959
FAX: 905-564-9728

EUROPE

AVX Limited, England European Headquarters

Tel: ++44 (0)1252 770000
FAX: ++44 (0)1252 770001

AVX S.A., France

Tel: ++33 (1) 69.18.46.00
FAX: ++33 (1) 69.28.73.87

AVX GmbH, Germany - AVX

Tel: ++49 (0) 8131 9004-0
FAX: ++49 (0) 8131 9004-44

AVX GmbH, Germany - Elco

Tel: ++49 (0) 2741 2990
FAX: ++49 (0) 2741 299133

AVX srl, Italy

Tel: ++390 (0)2 614571
FAX: ++390 (0)2 614 2576

AVX Czech Republic, s.r.o.

Tel: ++420 (0)467 558340
FAX: ++420 (0)467 558345

ASIA-PACIFIC

AVX/Kyocera, Singapore Asia-Pacific Headquarters

Tel: (65) 258-2833
FAX: (65) 350-4880

AVX/Kyocera, Hong Kong

Tel: (852) 2-363-3303
FAX: (852) 2-765-8185

AVX/Kyocera, Korea

Tel: (82) 2-785-6504
FAX: (82) 2-784-5411

AVX/Kyocera, Taiwan

Tel: (886) 2-2696-4636
FAX: (886) 2-2696-4237

AVX/Kyocera, China

Tel: (86) 21-6249-0314-16
FAX: (86) 21-6249-0313

AVX/Kyocera, Malaysia

Tel: (60) 4-228-1190
FAX: (60) 4-228-1196

Elco, Japan

Tel: 045-943-2906/7
FAX: 045-943-2910

Kyocera, Japan - AVX

Tel: (81) 75-604-3426
FAX: (81) 75-604-3425

Kyocera, Japan - KDP

Tel: (81) 75-604-3424
FAX: (81) 75-604-3425

Contact:



<http://www.avxcorp.com>

S-CPEM10M1000-N