

***DCS 50-40 M16***  
***Power Supply***

**Instruction Manual**

**Sorensen**  
The power you need

## **SORENSEN FIVE-YEAR WARRANTY**

---

Sorensen, a division of Elgar Electronics Corporation, warrants its products to be free from defects in material and workmanship. This warranty is effective for five years from the date of shipment of the product to the original purchaser. Liability of Sorensen under this warranty shall exist provided that:

- the Buyer exposes the product to normal use and service and provides normal maintenance on the product;
- Sorensen is promptly notified of defects by the Buyer and that notification occurs within the warranty period;
- the Buyer receives a Return Material Authorization (RMA) number from Sorensen's Repair Department prior to the return of the product to Sorensen for repair, phone 800-458-4258;
- the Buyer returns the defective product in the original, or equivalent, shipping container;
- if, upon examination of such product by Sorensen it is disclosed that, in fact, a defect in materials and/or workmanship does exist, that the defect in the product was not caused by improper conditions, misuse, or negligence; and,
- that Sorensen QA seal and nameplates have not been altered or removed and the equipment has not been repaired or modified by anyone other than Sorensen authorized personnel.

This warranty is exclusive and in lieu of all other warranties, expressed or implied, including, but not limited to, implied warranties of merchantability and fitness of the product to a particular purpose. Sorensen, its agents, or representatives shall in no circumstance be liable for any direct, indirect, special, penal, or consequential loss or damage of any nature resulting from the malfunction of the product. Remedies under this warranty are expressly limited to repair or replacement of the product.

### **CONDITIONS OF WARRANTY**

- To return a defective product, contact a Sorensen representative or the Sorensen factory for an RMA number. Unauthorized returns will not be accepted and will be returned at the shipper's expense.
- For Sorensen products found to be defective within thirty days of receipt by the original purchaser, Sorensen will absorb all ground freight charges for the repair. Products found defective within the warranty period, but beyond the initial thirty-day period, should be returned prepaid to Sorensen for repair. Sorensen will repair the unit and return it by ground freight pre-paid.
- Normal warranty service is performed at Sorensen during the weekday hours of 7:30 am to 4:30 pm Pacific time. Warranty repair work requested to be accomplished outside of normal working hours will be subject to Sorensen non-warranty service rates.
- Warranty field service is available on an emergency basis. Travel expenses (travel time, per diem expense, and related air fare) are the responsibility of the Buyer. A Buyer purchase order is required by Sorensen prior to scheduling.
- A returned product found, upon inspection by Sorensen, to be in specification is subject to an inspection fee and applicable freight charges.
- Equipment purchased in the United States carries only a United States warranty for which repair must be accomplished at the Sorensen factory.

**Sorensen**

*Committed to Quality...Striving for Excellence*

## Safety Notice

Before applying power to the system, verify that the DCS Series unit is configured properly for the user's particular application.



### WARNING!

**HAZARDOUS VOLTAGES IN EXCESS OF 280 VRMS, 600V PEAK MAY BE PRESENT WHEN COVERS ARE REMOVED. QUALIFIED PERSONNEL MUST USE EXTREME CAUTION WHEN SERVICING THIS EQUIPMENT. CIRCUIT BOARDS, TEST POINTS, AND OUTPUT VOLTAGES MAY BE FLOATING ABOVE (BELOW) CHASSIS GROUND.**

Installation and service must be performed by qualified personnel who are aware of dealing with attendant hazards. This includes such simple tasks as fuse verification.

Ensure that the AC power line ground is connected properly to the DCS Series unit input connector or chassis. Similarly, other power ground lines including those to application and maintenance equipment must be grounded properly for both personnel and equipment safety.

Always ensure that facility AC input power is de-energized prior to connecting or disconnecting the input/output power cables.



During normal operation, the operator does not have access to hazardous voltages within the chassis. However, depending on the user's application configuration, **HIGH VOLTAGES HAZARDOUS TO HUMAN SAFETY** may be generated normally on the output terminals. Ensure that the output power lines are labeled properly as to the safety hazards and that any inadvertent contact with hazardous voltages is eliminated. To guard against risk of electrical shock during open cover checks, do not touch any portion of the electrical circuits. Even when the power is off, capacitors can retain an electrical charge. Use safety glasses during open cover checks to avoid personal injury by any sudden failure of a component.

Due to filtering, the unit has high leakage current to the chassis. Therefore, it is essential to operate this unit with a safety ground.

Some circuits are live even with the front panel switch turned off. Service, fuse verification, and connection of wiring to the chassis must be accomplished at least five minutes after power has been removed via external means; all circuits and/or terminals to be touched must be safety grounded to the chassis.

After the unit has been operating for some time, the metal near the rear of the unit may be hot enough to cause injury. Let the unit cool before handling.

Qualified service personnel need to be aware that some heat sinks are not at ground, but at high potential.

These operating instructions form an integral part of the equipment and must be available to the operating personnel at all times. All the safety instructions and advice notes are to be followed.

Neither Sorensen, San Diego, California, USA, nor any of the subsidiary sales organizations can accept any responsibility for personal, material or consequential injury, loss or damage that results from improper use of the equipment and accessories.

## About This Manual

This manual has been written expressly for the Sorensen DCS series of power supplies which have been designed and certified to meet the 1997 Low Voltage and Electromagnetic Compatibility Directive Requirements of the European Community. Units that comply with the directive are designated by an 'E' after the model designator (e.g., DCS 40-25E would indicate that the model is certified) when configured for 230 VAC input only.

Since the goal of the Low Voltage Directive is to ensure the safety of the equipment operator, universal graphic symbols (see below) have been used both on the unit itself and in this manual to warn the operator of potentially hazardous situations.

### Safety Symbols



**CAUTION**  
Risk of Electrical Shock



**CAUTION**  
Refer to Accompanying Documents



Off (Supply)



Standby (Supply)



On (Supply)



Protective Conductor Terminal



Direct Current (DC)



Alternating Current (AC)



Three-Phase Alternating Current

# Table of Contents

## SECTION 1. FEATURES AND SPECIFICATIONS

1.1 DESCRIPTION.....	1-1
1.2 OPERATING MODES .....	1-1
1.3 POWER SUPPLY FEATURES.....	1-1
1.4 SPECIFICATIONS.....	1-2
1.4.1 Electrical Specifications.....	1-2
1.4.2 Mechanical Specifications.....	1-3

## SECTION 2. INSTALLATION AND OPERATING INSTRUCTIONS

2.1 GENERAL.....	2-1
2.2 INITIAL INSPECTION .....	2-1
2.3 INSTALLATION AND WIRING .....	2-1
2.3.1 AC Input Power Requirements.....	2-1
2.3.2 AC Input Connector Assembly.....	2-2
2.3.3 Strain Relief Assembly.....	2-3
2.3.4 Input Line Impedance.....	2-5
2.3.5 Ventilation Requirements.....	2-5
2.3.6 Output Voltage Biasing.....	2-5
2.3.7 Rack Mounting.....	2-5
2.4 CONTROLS, CONNECTORS, AND INDICATORS.....	2-7
2.4.1 Front Panel.....	2-7
2.4.2 Rear Panel.....	2-7
2.5 INITIAL FUNCTIONAL TESTS.....	2-8
2.6 STANDARD OPERATION.....	2-10
2.6.1 Load Conductor Ratings.....	2-10
2.6.2 Load Connection and Grounding.....	2-10
2.6.3 Remote Sensing.....	2-10
2.6.4 Negative Output Operation.....	2-11
2.7 SINGLE SUPPLY OPERATION (LOCAL MODE).....	2-11
2.8 MULTIPLE SUPPLIES.....	2-12
2.9 OVER VOLTAGE PROTECTION (OVP).....	2-12
2.9.1 Remote Programming of OVP With External Voltage Sources.....	2-12
2.9.3 Remote Programming of OVP with an External Resistance.....	2-14
2.9.4 Remote Programming of OVP with External Current Sources.....	2-15
2.9.5 Remote OVP Sensing.....	2-16
2.10 REMOTE ON/OFF.....	2-16
2.10.1 Remote ON/OFF by Contact Closure.....	2-16
2.11 REMOTE PROGRAMMING OF OUTPUT VOLTAGE AND CURRENT LIMIT.....	2-17
2.11.1 Programming With External Voltage Sources.....	2-18
2.11.2 Programming With an External Resistance.....	2-19
2.11.3 Programming With an External Current Source.....	2-21
2.12 REMOTE MONITORING AND STATUS INDICATORS.....	2-22

## Table of Contents (continued)

### SECTION 3. THEORY OF OPERATION

3.1 POWER CIRCUIT (A2 ASSEMBLY).....	3-1
3.1.1 Basic Off-Line Switching Regulator Theory.....	3-1
3.1.2 Simplified Full Bridge Converter Theory.....	3-1
3.1.3 Detailed Circuit Description.....	3-3

### SECTION 4. MAINTENANCE, TROUBLESHOOTING, AND CALIBRATION

4.1 GENERAL.....	4-1
4.2 PERIODIC SERVICE.....	4-1
4.3 TROUBLESHOOTING.....	4-1
4.3.1 Preliminary Checks.....	4-1
4.3.2 Internal Troubleshooting.....	4-2
4.4 CALIBRATION.....	4-2

### SECTION 5. PARTS LISTS

5.1 GENERAL.....	5-1
5.2 PARTS ORDERING.....	5-1
5.2 PARTS LISTS.....	5-1

### SECTION 6. DRAWINGS AND SCHEMATICS

6.1 GENERAL.....	6-1
6.2 DRAWINGS AND SCHEMATICS.....	6-1



## **SECTION 1. FEATURES AND SPECIFICATIONS**

### **1.1 Description**

The DCS 50-40M16 is a 2kW power supply designed to provide highly stable, regulated DC current. The DCS unit employs high frequency switching regulator technology to achieve high power density and small package size.

### **1.2 Operating Modes**

The DCS supply has two basic operating modes: Constant Voltage and Constant Current. In constant voltage mode the output voltage is regulated at the selected value while the output current varies with the load requirements. In constant current mode the output current is regulated at the selected value while output the voltage varies with the load requirements.

An automatic crossover system enables the unit to switch operating modes in response to varying load requirements. If, for example, the unit is operating in voltage mode and the load current attempts to increase above the setting of the current control, the unit will switch automatically from voltage mode to current mode. If the load current is subsequently reduced below the setting of the current control the unit will return to voltage mode automatically.

### **1.3 Power Supply Features**

- 190-250 Vac single or 3-phase input, 47-63 Hz
- Ten turn locking potentiometer current control permits high resolution setting of the output current from zero to the rated output
- Automatic mode crossover into current or voltage mode
- Flexible output configuration: multiple units can be connected in parallel or series to provide increased current or voltage
- High frequency switching technology allows high power density, providing increased power output in a small, light package
- Remote sensing to compensate for losses in power leads
- Preset Over-Voltage Protection (OVP)
- External TTL, AC or DC shutdown
- Remote voltage, resistive, current limit and OVP programming with selectable programming constants
- External indicator signals for remote monitoring of OVP status, local/remote programming status, thermal shutdown, and output voltage and current
- Front panel test points for current monitor

## 1.4 Specifications

### 1.4.1 Electrical Specifications<sup>1</sup>

#### Input Power

<b>Voltage:</b>	190-250 Vac, single or three phase
<b>Frequency:</b>	47-63 Hz
<b>Current:</b>	14 A RMS maximum at 208 Vac 3 phase, with 2 kW load 20 A RMS maximum at 208 Vac 1 phase, with 2 kW load
<b>Power Factor:</b>	0.85 minimum at 100% load, 3 phase AC input 0.55 minimum at 100% load, 1 phase AC input
<b>Efficiency:</b>	85% minimum at 100% load
<b>Inrush:</b>	Peak value of line current should not be greater than two times the full load peak value during turn-on or restart

#### Output Power

<b>Power:</b>	2000 Watts maximum, 0 watts minimum
<b>Voltage:</b>	Internally set for a maximum compliance of 53V +/- 1 Vdc
<b>Current:</b>	Adjustable from 0 to 38 Adc
<b>Ripple Voltage:</b>	200 mV peak-to-peak, 20 mV RMS, 20 MHz limited
<b>Ripple Current:</b>	40 ma p-p, 5 ma RMS, 50 Hz - 20 MHz (10-30 Adc)
<b>Line Regulation:</b>	+/- 0.1% line regulation in voltage or current mode of operation, with constant load and temperature at point of voltage sense
<b>Load Regulation:</b>	+/- 0.1% load regulation in voltage or current mode of operation, with constant line and temperature at point of voltage sense
<b>Response Time:</b>	Less than 1 ms recovery to 1% band for 30% step load changes from 70% to 100% or 100% to 70%
<b>Overshoot:</b>	Less than 10% of max rated output voltage
<b>Undershoot:</b>	Less than 10% of max rated output voltage
<b>Drift:</b>	Less than 0.05% over 8 hours in voltage or current mode after 30 minute warmup period
<b>Temperature Coefficient:</b>	Less than 0.02% per deg C (voltage), less than 0.03% per deg C (current)
<b>Voltage Differential:</b>	150 Vdc max from output or voltage and current monitors to safety ground
<b>Output Capacitance:</b>	10,000 $\mu$ F, nominal

<sup>1</sup> Specifications are warranted over a temperature range of 0-50°C with default local sensing. From 50-70°C, derate output 2% per °C.

<sup>2</sup> Maximum drift over 8 hours with constant line, load, and temperature, after 20 minute warm-up

<sup>3</sup> Change in output per °C change in ambient temperature, with constant line and load



**Additional Characteristics**

<b>Maximum Remote Sense Line Drop Compensation/line:</b>	1 Volt
<b>Storage Temperature Range:</b>	-55 to +85°C
<b>Humidity Range:</b>	0 to 90% Non-condensing
<b>Altitude</b>	6,000 ft
<b>Time Delay from Power On until Output Stable:</b>	3 seconds maximum
<b>Voltage Mode Transient Response Time:</b>	1mS recovery to 1% band for 30% step load change from 70% to 100% or 100% to 70%
<b>Remote Start/Stop and Interlock:</b>	TTL compatible input, Contact Closure, 12-250 Vac or 12-130 Vdc
<b>Switching Frequency:</b>	Nominal 65 kHz (130 kHz output ripple)
<b>Agency Approvals:</b>	CE Mark Installation Category II, Pollution Degree 2, For indoor use only.

**Programming and Readback**

<b>External Programming Signals:</b>	0-5 Vdc for voltage 0-5 Vdc for current
<b>Programming Linearity:</b>	+/- 1%
<b>Programming Accuracy:</b>	+/- 5%
<b>Rear Panel Analog Monitor:</b>	0-5 Vdc for voltage 0-10 Vdc for current
<b>Monitor Linearity:</b>	+/- 1%
<b>Monitor Accuracy:</b>	+/- 5% for voltage +/- 1% for current

**1.4.2 Mechanical Specifications****Single Unit**

<b>Height:</b>	89 mm (3.50 in)
<b>Width:</b>	482.6 mm (19 in)
<b>Depth:</b>	508 mm (20 in)
<b>Weight:</b>	12.2 kg (27 lbs)

**Rear Panel Input and Output Connectors**

<b>AC Input Connector:</b>	<u>3-Phase</u> J1-X - 208 Vac input J1-Y - 208 Vac input J1-Z - 208 Vac input J1-C - Safety Ground	<u>1-Phase</u> 230 Vac Input 230 Vac Input Not Used Safety Ground
<b>Input Power:</b>	Chassis Connector – AMP #641685-2 Pins – AMP #35082-1 Mating Connector – AMP #643267-1 Pins – AMP #35082-1	
<b>Output Connector:</b>	Left busbar - Positive output Right busbar - Negative output	
<b>Busbar Material:</b>	Copper busbars, nickel plated	
<b>Busbar Dimensions:</b>	1.365" long x 0.8" wide x 0.125" thick	
<b>Busbars Spacing:</b>	2.2" center to center spacing	
<b>Busbar Hole size:</b>	Two, 0.257" dia holes on 0.5" centers for 1/4" hardware and two, 0.191" dia holes on 0.4" centers for #10 hardware	
<b>Remote Current Monitor Output and Programming Input:</b>	25 pin Subminiature D connector, J3.	

**Front Panel Controls and Indicators**

<b>Current Control:</b>	Current limit control potentiometer provided with locking mechanism Wrench and/or screwdriver required to change setting
<b>Power-On Indicator:</b>	Green LED provided to indicate power-on status condition
<b>Failure Indicator:</b>	Red LED provided to indicate unit is in a shutdown condition due to over-voltage
<b>Front Panel Current Monitor:</b>	Two test jacks provided, red (+) and black (-) Accept single or dual banana plugs on 0.75" centers to monitor output current
<b>Current Monitor Range:</b>	100 mV per amp of output current (0-4 Vdc)
<b>Monitor Linearity:</b>	+/- 1%
<b>Monitor Accuracy:</b>	+/- 1%

**Protection**

- Input Power:** Three pole companion trip circuit breaker, internal fuses
- Load Current:** Programmable Current limit (constant current operation)
- Temperature:** Over temperature shutdown
- OVP:** Crowbar type internally set to maximum of 115% of the maximum compliance voltage

**Cooling**

- Fan:** Self-contained fan, air enters at front sides and through the top cover and exhausts at rear of chassis

**SPECIFICATIONS SUBJECT TO CHANGE WITHOUT NOTICE**

**This page intentionally left blank.**

## **SECTION 2. INSTALLATION and OPERATING INSTRUCTIONS**

### **2.1 General**

After unpacking, perform an initial inspection and function test to ensure that the unit is in good working order. If the unit was damaged in shipment, notify the carrier immediately. Direct repair problems to the Service Department, Sorensen Company. Customer Service Inquiries: 1-800-458-4258.

### **2.2 Initial Inspection**

The equipment should be inspected for damage as follows:

- Inspect for obvious signs of physical damage.
- Loosen the front panel current control pot shaft locknut and turn front panel control from stop to stop. Rotation should be smooth.
- Test the action of the power switch. Switching action should be positive.
- If internal damage is suspected, remove the cover and check for printed circuit board and/or component damage. Reinstall cover.

### **2.3 Installation and Wiring**

Before using the DCS system power supply, you must determine your AC input power requirements and assemble an appropriate line cord and connector. The power supply is shipped with a kit of connector and strain relief parts which you assemble according to the procedures in this section.



#### **NOTE:**

Ensure the power supply is connected to an appropriately-rated AC outlet with the recommended AC input connector as set out in this section. There is a shock hazard if the power supply chassis and cover are not connected to an electrical ground via the safety ground in the AC input connector. The third wire in a single phase AC input connector and the fourth wire in a three phase AC input connector must be connected to an electrical ground at the power outlet. Disconnection of this ground causes a potential shock hazard to operating personnel.

This power supply is equipped with an AC line filter to reduce electromagnetic interference and must be connected to a properly-grounded receptacle, or a shock hazard will exist.

Operating the supply at line voltages or frequencies in excess of those specified may cause leakage currents in excess of 5.0mA peak from the AC line to the chassis ground.

#### **2.3.1 AC Input Power Requirements**

This supply may be operated from either a single phase or a three phase AC power source. The specifications for input voltage, current, and frequency are listed below.

<b>AC Input Voltage Range</b>	<b>Maximum Input Current</b>	<b>Frequency</b>
200-250Vac Single Phase	20Arms	47-63Hz
190-250Vac Three Phase	14Arms	47-63Hz

### 2.3.2 AC Input Connector Assembly

Each unit is shipped with a connector and contacts which mate with the chassis-mounted AC connector located on the rear panel. See **Figure 2.3-1 AC Connector and Contacts**.

#### Parts Supplied

- One (1) connector (Part number MI-6432-672)
- Five (5) contacts (Part number MC-3508-211)

#### Additional Parts Required

- 8 to 12 AWG wiring: three (3) wires for single phase inputs or four (4) wires for three phase inputs. The neutral wire of three-phase four (4) wire systems is not required.

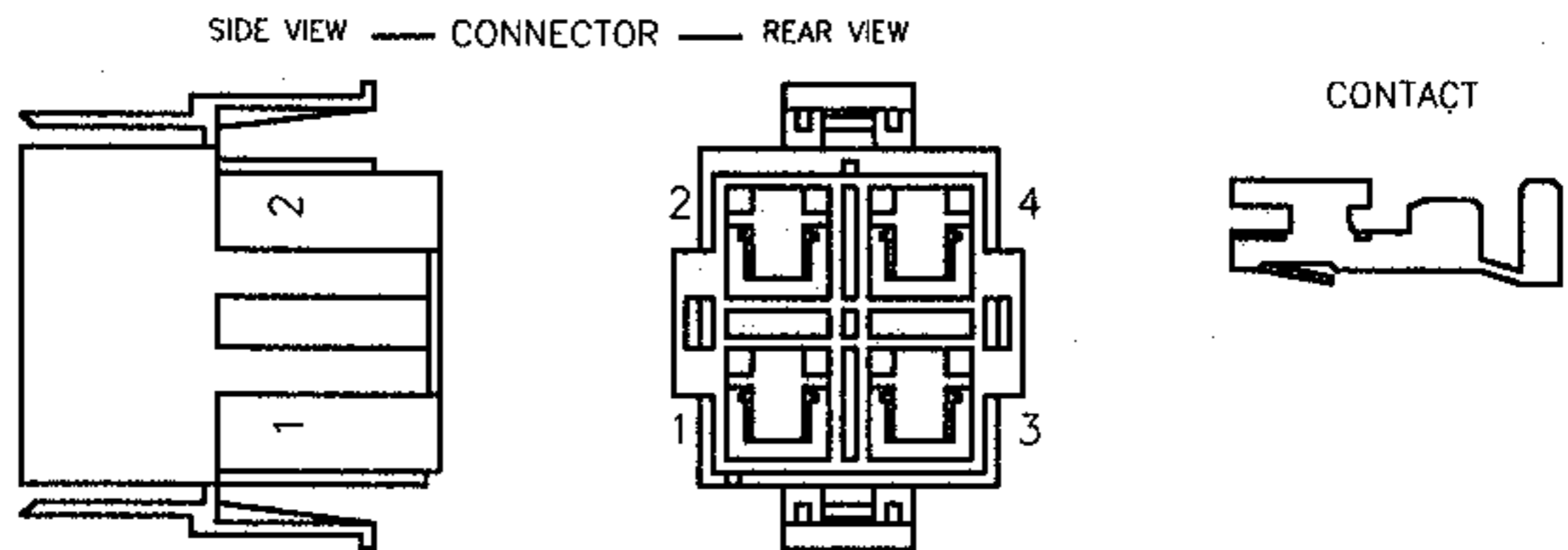

**Figure 2.3-1 AC Connector and Contacts**

#### Wire Preparation

1. Trim outer wire jacket 2". (Necessary for strain relief. See **Section 2.3.3**.)
2. Strip 0.300" at the end of the insulated AC input wire.
3. Crimp the stripped wire into the contact as indicated in **Figure 2.3-2**, then solder the connection.
4. Crimp the contact around the wire insulation as indicated in **Figure 2.3-2**.

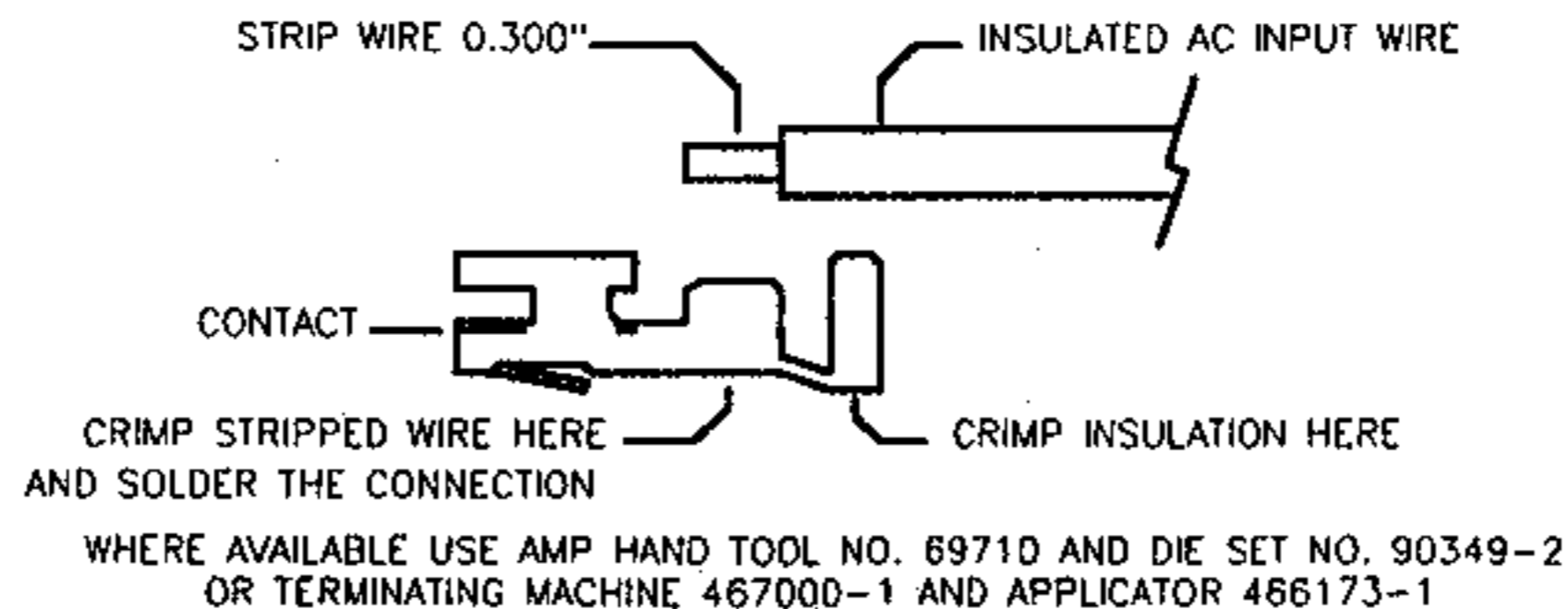
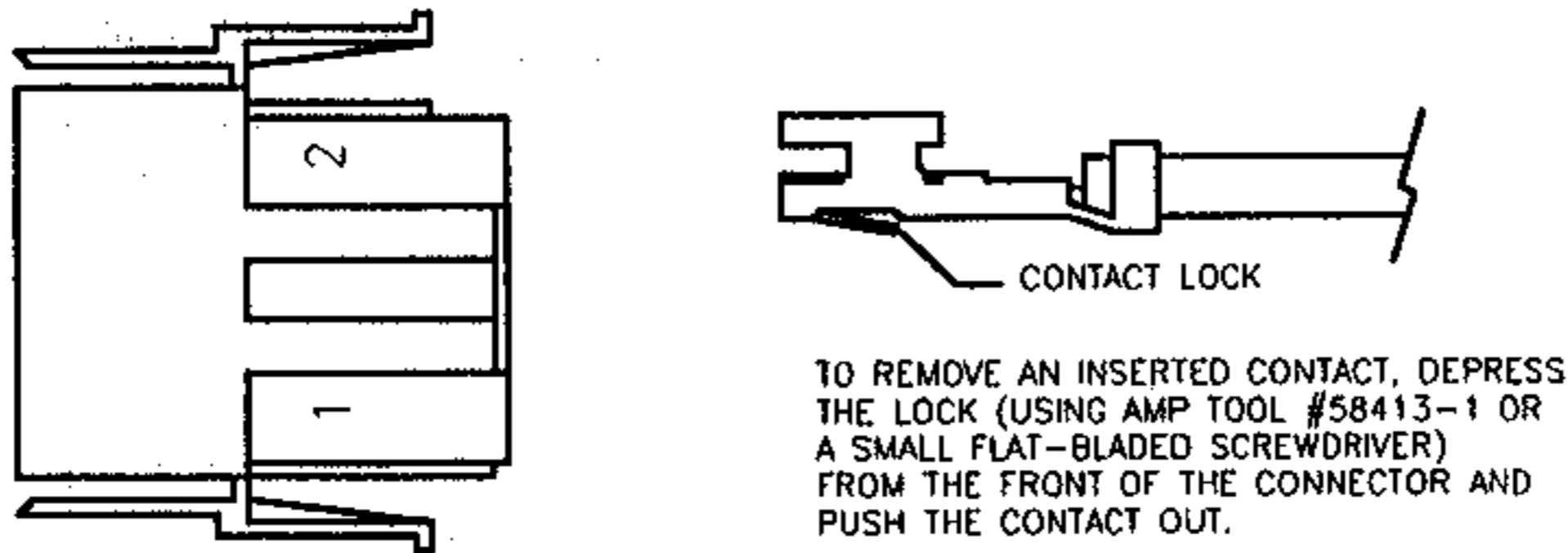

**Figure 2.3-2 Wire Preparation**



**Contact Installation**

5. Insert contact with attached wire into the connector until lock snaps into place. See **Figure 2.5-3 Contact Orientation** and **Figure 2.5-4 AC Wire Locations** to complete the connector for either single or three phase input.



**Figure 2.3-3 Contact Orientation**

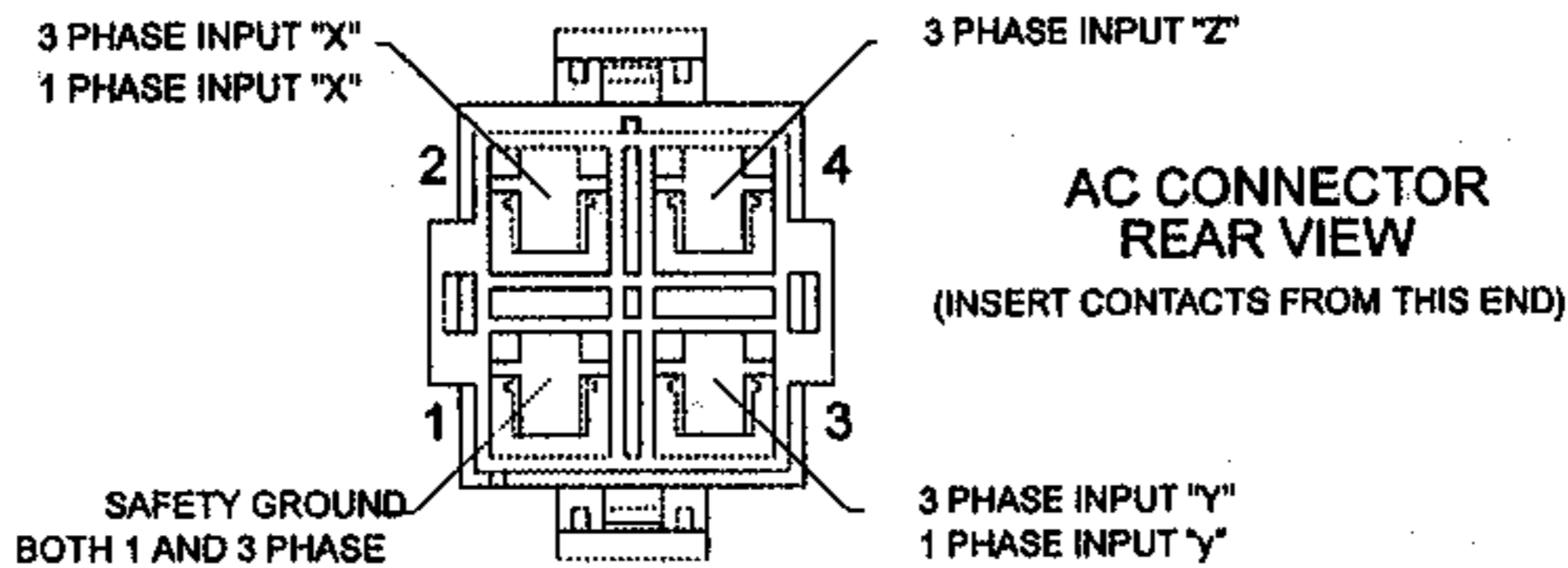

**Figure 2.3-4 AC Wire Locations**

**2.3.3 Strain Relief Assembly**

The strain relief is assembled from supplied pieces and attaches to the AC input connector to provide support for the AC input cord.

**Parts Supplied**

- Two (2) pieces strain relief (Part number MI-6432-661)
- Two (2) screws (Part number MS-6P12-10)

**Assembly Instructions**

1. Snap off the rectangular bushing attached to each piece of the strain relief. See Figure 2.3-5.

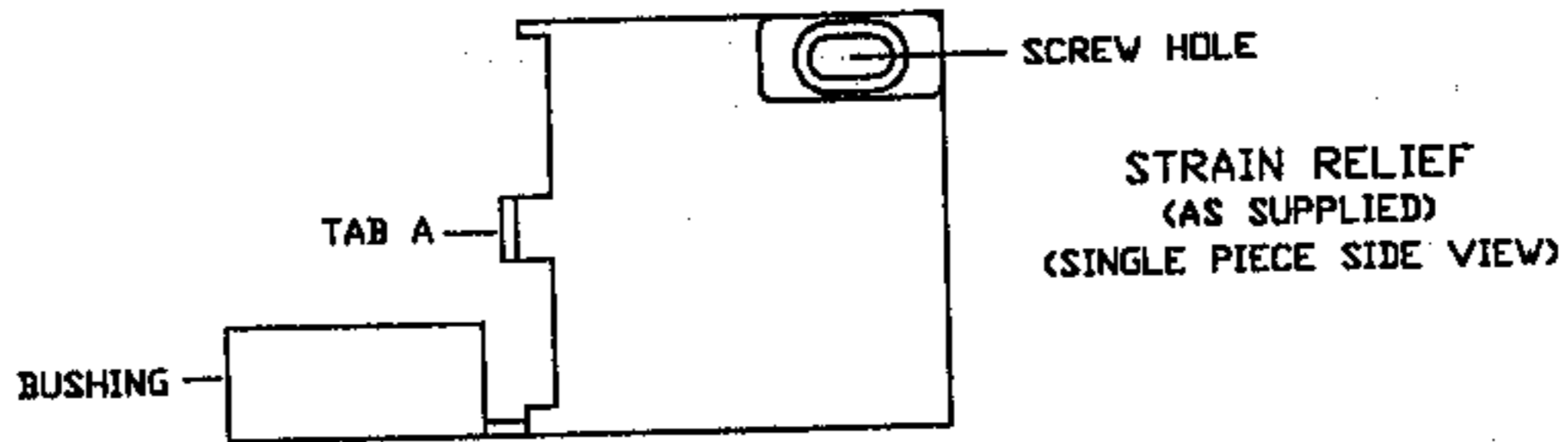

Figure 2.3-5 Strain Relief (1 piece)

2. Install bushings on strain relief pieces, if required.

If cable diameter is within ...	Then ...
0.1" to 0.4"	Install bushings
0.5" to 0.74"	Do not use bushings

3. Insert strain relief tab A into AC input connector slot B. Insert second strain relief tab A into AC input connector slot C. See Figure 2.3-6.
4. Install screws in holes provided on outside of strain relief pieces. Thread through to screw standoff inside opposite piece. Tighten to clamp outer jacket of AC wire securely, ensuring that the side of the strain relief slips into the corresponding rabbet on the opposite piece.

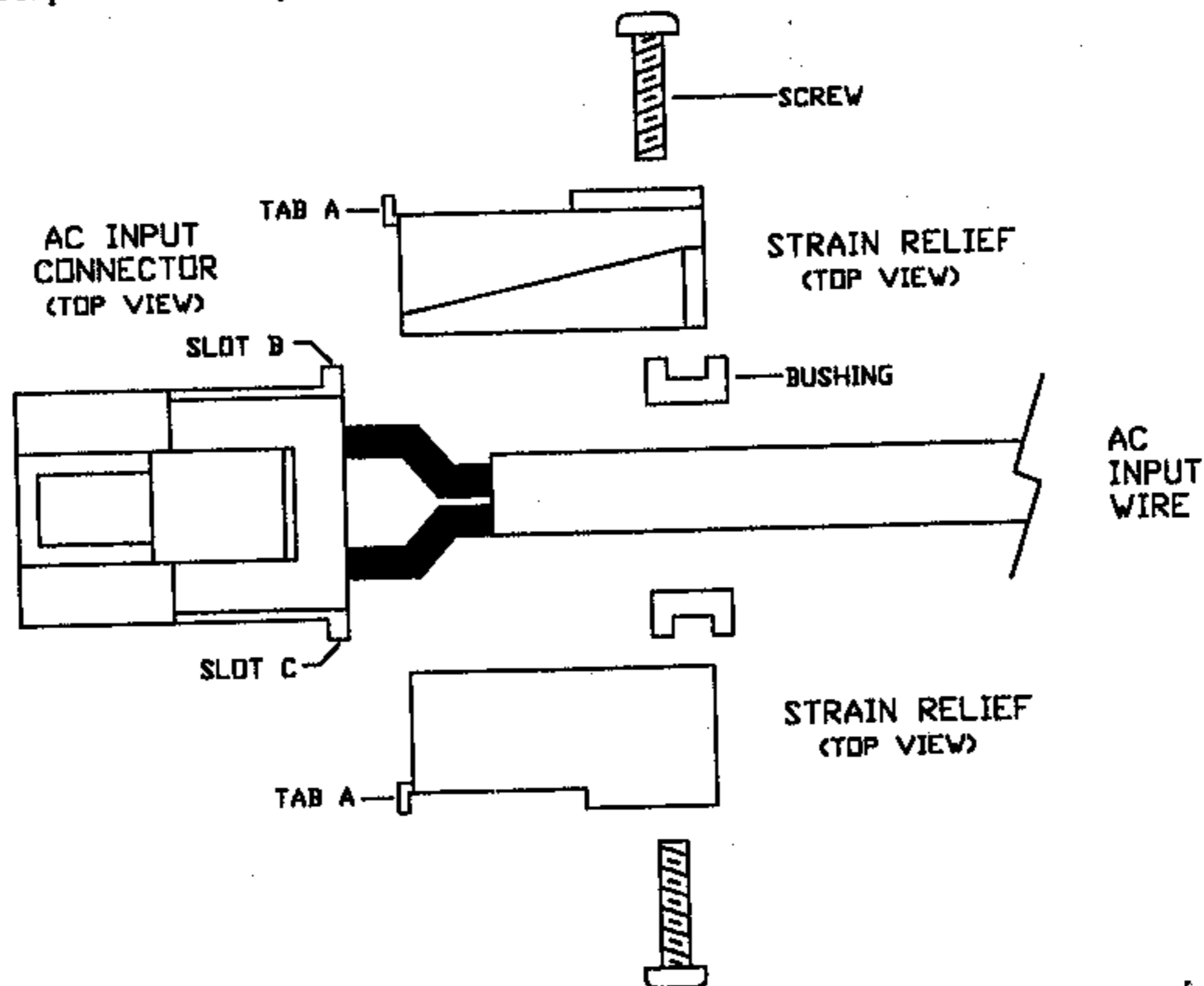

Figure 2.3-6 Strain Relief Assembly

### 2.3.4 Input Line Impedance

The maximum input line impedance for operation at full rated output is 0.5 ohm. Higher source impedances can be tolerated by raising the input line voltage or by reducing the output voltage and/or current.

### 2.3.5 Ventilation Requirements

The DCS power supply may be used in rack mounted or benchtop applications. In either case sufficient space must be allowed for cooling air to reach the ventilation inputs on each side of the unit and for the fan exhaust air to exit from the rear of the unit.

### 2.3.6 Output Voltage Biasing



If the output voltage is to be biased relative to safety ground, the power supply outputs may be biased up to a maximum of 150Vdc with respect to the chassis.

### 2.3.7 Rack Mounting

The supply is designed to fit in a standard 19" equipment rack. Bolt holes in the chassis sides are provided for rack mount slides such as the ZERO #C300S18 slides. When installing the unit in a rack be sure to provide adequate support for the rear of the unit while not obstructing the ventilation inlets on the sides of the unit.

#### CAUTION

Rack mounting bolts must not extend more than 3/16" into the side of the power supply.

REAR VIEW

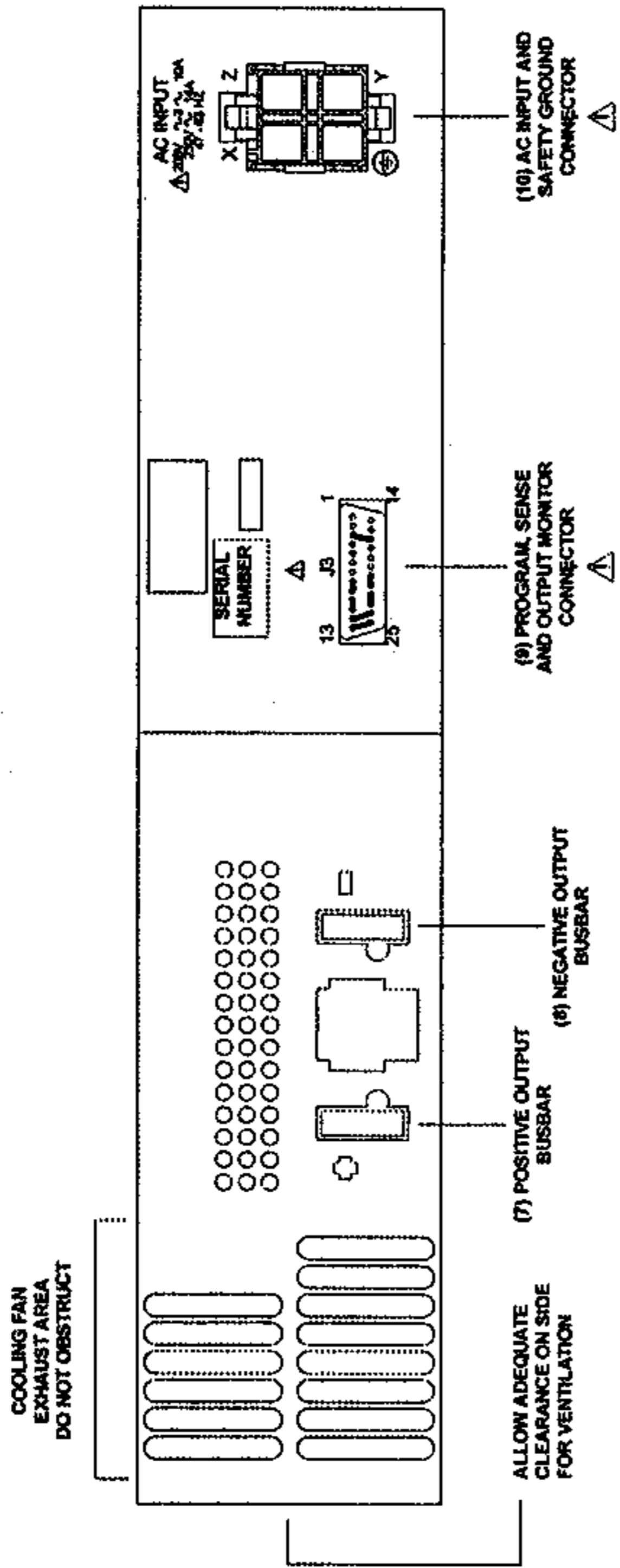

FRONT VIEW

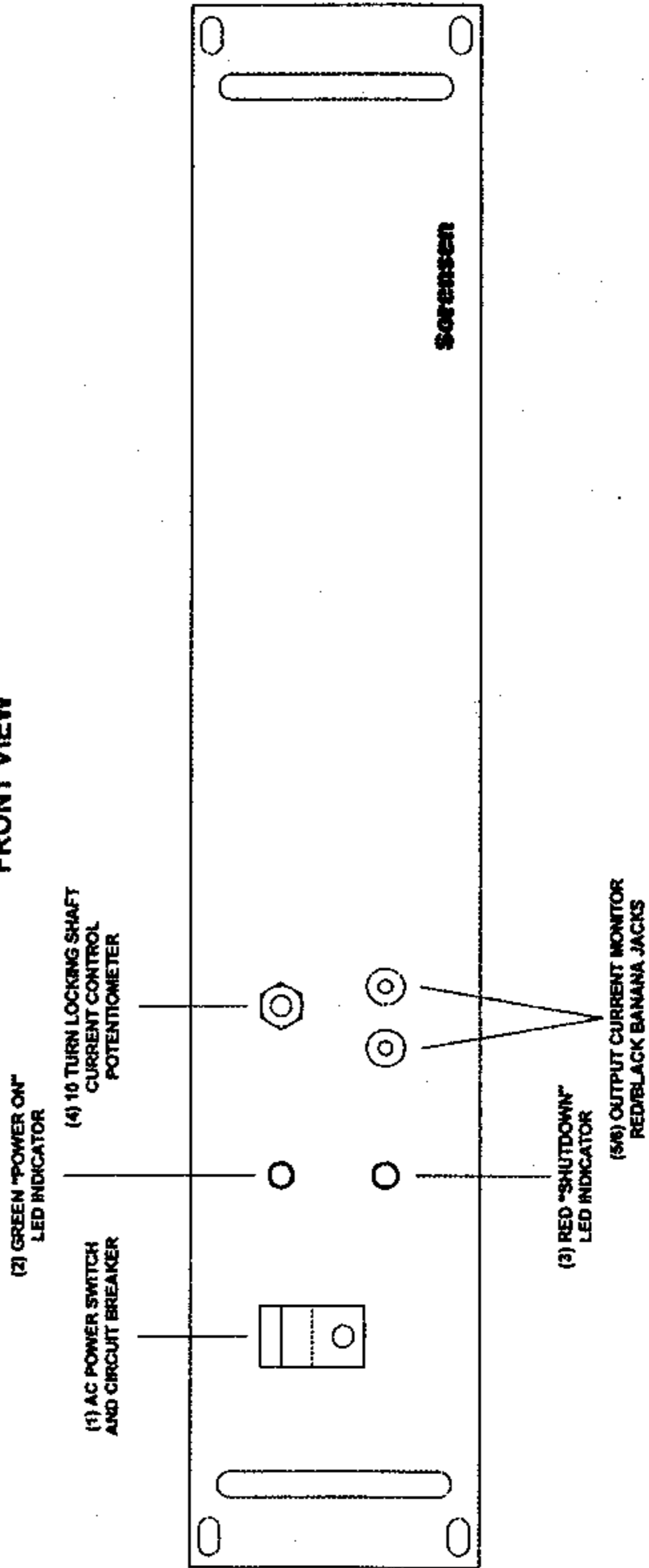

Figure 2-1

## 2.4 Controls, Connectors, and Indicators

Refer to Figure 2-1 and the descriptions below.

### 2.4.1 Front Panel

1. AC Power Switch/Circuit Breaker
2. Green Power On LED Indicator
3. Red Shutdown LED Indicator
4. Output Current Control: Multi-turn potentiometer with locking shaft used to adjust the output current limit in local mode.
5. Current Monitor Output, 100 mv/Amp (red)
6. Current Monitor Return (black)

### 2.4.2 Rear Panel

7. Positive Output Busbar
8. Negative Output Busbar
9. Programming, Sense and Monitor Connector J3: Input connector for programming signals. Also provides access to sense connections and monitoring points. See Table 2-1 for individual pin descriptions.
10. AC Input Connector

## 2.5 Initial Functional Tests

Before connecting the unit to an AC outlet, make sure that the power switch is in the OFF position and that the current control is turned fully counterclockwise. Check that the J3 mating connector on the rear of the unit is in place with jumpers connected for local operation as shown below. (This is the default configuration as shipped from the factory). Connect the unit to a grounded outlet and switch the unit on. After a short power on delay, the green "power on" LED will light and voltage will be available at the rear panel busbars.

CONNECTOR J3

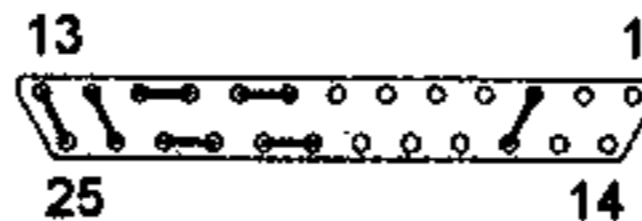

Connector J3 Configuration for Local Operation

To check current mode operation, proceed as follows:

- Set the POWER switch to OFF.
- Rotate the CURRENT control fully counterclockwise.
- Connect a high current DC ammeter across the rear output terminals, observing correct polarity. Select leads of sufficient current carrying capacity and an ammeter range compatible with the unit's rated current output. The ammeter should have an accuracy of better than 0.5%.
- Set the POWER switch to ON.
- Rotate the CURRENT control slowly clockwise. The control range should be from zero to the maximum rated output. Compare the test meter reading with the reading on the front panel test points. Check that the green power on indicator LED is on.
- Set the POWER switch to OFF.



**Table 2-1 J3 Program, Sense and Monitor Connector Description  
(D-subminiature 25 Pin Female) \***

<b>PIN NUMBER</b>	<b>FUNCTION</b>
1.....	AC/DC Shutdown Input (12-250Vac or 12-130Vdc)
14	TTL Shutdown Input
2.....	Return for Shutdown Input Signals
15	+12Vdc Output (1k ohm source impedance)
3.....	OVP Programming Input (0-5V, 0-10V or 0-1mA) Jumpered to pin 16 for local mode operation
16	1mA Current Source for Local OVP Control or Remote Resistive OVP Programming
4.....	Remote Programming Indicator High = Remote Programming Low = Local Control
17	OVP Status (High = OVP Circuit Activated)
5.....	Operating Mode Indicator High = Voltage Mode Low = Current Mode
18	Thermal Shutdown Indicator (High = Shutdown)
6.....	Ground
19	Output Voltage Monitor (Uncalibrated) 0-5V = 0-100%
7.....	Output Current Monitor (Calibrated) 0-10V = 0-100%
20	Output Voltage Control (Local Mode) Jumpered to pin 21 for local operation
8.....	Output Voltage Control (Remote Programming) Input for 0-1mA remote programming signal Jumpered to pin 9 for local operation and remote current source programming
21	1mA Current Source for Local Operation or Remote Resistive Programming of Output Voltage Jumpered to pin 20 for local operation
9.....	Remote Voltage Programming Input (0-5V or 0-10V) Jumpered to pin 8 for local operation and remote current source programming
22	1mA Current Source for Local Operation or Remote Resistive Programming of Output Current Limit Jumpered to pin 23 for local operation
10.....	Remote Current Programming Input (0-100mV, 0-5V or 0-10V) Jumpered to pin 11 for local operation and remote current source programming
23	Output Current Control (Local Mode) Jumpered to pin 22 for local operation
11.....	Output Current Control (Remote Programming) Input for 0-1mA external programming signal Jumpered to pin 10 for local operation and remote current source programming
24	Return (for local sense connections only)
12.....	Return Sense (Return for Remote Programming Inputs)
25	Positive Output (for local sense connections only)
13.....	Positive Sense

\* Mating connector - 25 pin male ITT Cannon DB25P or equivalent.

## 2.6 Standard Operation

Front panel operation of the DCS unit is limited to the On/Off switch and a single 10-turn potentiometer used to adjust the output current. Standard DCS Series front panel controls not available on this model include voltage control and over-voltage protection potentiometers. The maximum value of these parameters has been preset at the factory using fixed resistors. The maximum output voltage has been set to 54V; the maximum OVP setting is 58V. Adjustments to these parameters are made remotely through the rear J3 connector. Throughout this section, all references to changing these parameters imply adjustment through the J3 connector. Refer to the applicable paragraphs for remote programming information using voltage, current, or resistance references.

Reliable performance of the DCS power supply can be obtained if certain basic precautions are taken when connecting it for use on the lab bench or installing it in a system.

To obtain a stable, low noise output, careful attention should be paid to factors such as conductor ratings, system grounding techniques and the way in which the load and remote sensing connections are made.

### 2.6.1 Load Conductor Ratings

The table below lists the maximum allowable load wiring length (in feet) for a specified wire gauge for the power supply operating at full rated output. The lengths indicated are based on PVC insulated wire with a maximum operating temperature of 105°C. To overcome impedance and coupling effects which can degrade the power supply performance the use of leads of the largest gauge and shortest length possible is recommended.

WIRE SIZE (AWG)	2	4	6	8	10	12
LENGTH (FEET)	30	30	30	30	16	10

### 2.6.2 Load Connection and Grounding

Proper connection of distributed loads is an important aspect of power supply application. A common mistake is to connect leads from the power supply to one load, from that load to the next load, and so on for each load in the system. In this **parallel power distribution** method, the voltage at each load depends on the current drawn by the other loads and DC ground loops are developed. Except for low current applications, this method should not be used.

The preferred way to distribute power is by the **radial distribution** method in which power is connected to each load individually from a single pair of terminals designated as the positive and negative distribution terminals. The pair of terminals may be the power supply output terminals, the terminals of one of the loads or a distinct set of terminals specially established for distribution. Connecting the sense leads to these terminals will compensate for losses and minimize the effect of one load upon another.

### 2.6.3 Remote Sensing

The use of remote sensing permits the regulation point of the power supply to be shifted from the output terminals to the load or other distribution terminals thereby automatically compensating for the voltage losses in the leads supplying the load (provided these losses do not exceed 1V/line. For example, with the voltmeter reading 10.0 volts and the sense lines connected directly to the load, the load voltage will remain regulated at 10.0 volts regardless of the voltage drops in the power leads and variations in the load current.

The positive sense connection is available at pin 13 of connector J3 and the return sense connection is available at pin 12. For local sensing (regulation at the power supply output terminals) the sense pins are connected to pins 25

(positive output) and 24 (return) of connector J3. For remote sensing the local operation jumpers are removed and pins 13 and 12 are connected directly to the positive and negative terminals of the load.

Sense wires can be any size (24AWG or larger) but in high noise environments or when the lowest possible power supply ripple is required, sense wires must be twisted and/or shielded.

 **NOTE:**

The sense leads must always be connected, either for remote or local sensing. Operation of the supply with the sense leads disconnected will cause the output to fall to zero or to be unregulated.

 **NEVER** use the sense connections without the normal power lead connections to the output terminals. Avoid reversing positive and negative sense lead connections.

**2.6.4 Negative Output Operation**

Operation of the unit as a negative output supply may be accomplished by referencing the positive output terminal to the power supply chassis or some other common system ground. The voltage monitor, being referenced to the negative output, will indicate the absolute value of the actual output voltage.

**2.7 Single Supply Operation (Local Mode)**



To operate the DCS power supply in local mode, first install the unit and connect the load following the instructions in Sections 2.1 to 2.6. Check that switch SW1 (mounted internally on the main printed circuit board) is set for local operation and that the J3 mating connector on the rear of the unit is in place with jumpers connected for local operation. (Note: This is the default configuration as shipped from the factory. See the diagram below.) Set both the current and voltage controls fully counterclockwise.

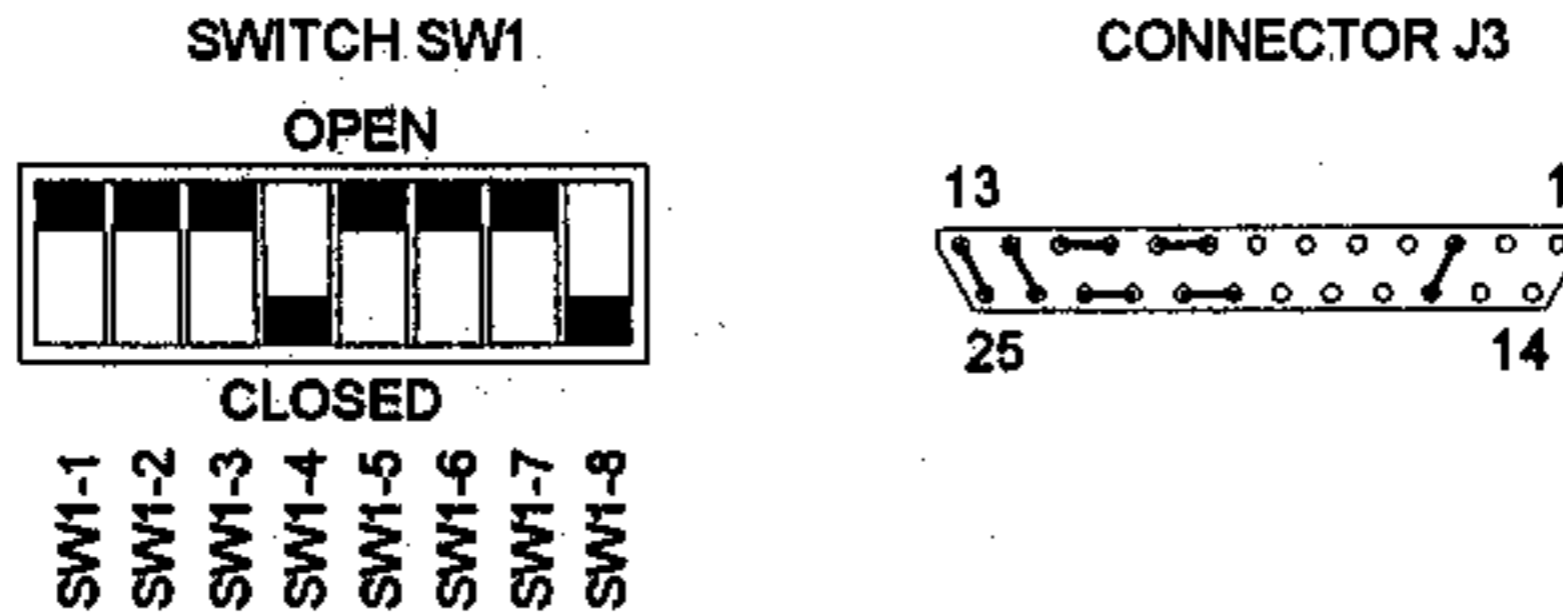

- Switch SW1**
- SW1-1 Off (Open)
  - SW1-2 Off (Open)
  - SW1-3 Off (Open)
  - SW1-4 On (Closed)
  - SW1-5 Off (Open)
  - SW1-6 Off (Open)
  - SW1-7 Off (Open)
  - SW1-8 On (Closed)

Switch SW1 and Connector J3 Configuration for Local Operation (default factory settings)

For current mode operation, turn the current control fully counterclockwise and connect an appropriately sized shorting jumper across the output terminals. Turn the current control clockwise until the desired output current is obtained. Turn the power supply off and remove the shorting jumper.

Note that for a short period (less than 3 seconds) after power on, the power supply output is disabled while the main filter capacitors charge through the inrush limiter.

## 2.8 Multiple Supplies

DCS Series power supplies of the SAME MODEL may be operated with outputs in series or parallel to obtain increased load voltage or current. Split supply operation allows two positive or a positive and negative output to be obtained.

As permanent, fixed modifications have been made to the standard DCS circuitry of this model, please consult the factory for detailed instructions outlining the proper wiring and operation of multiple supplies for your specific application.

## 2.9 Over Voltage Protection (OVP)

The OVP circuit allows for protection of the load in the event of a remote programming error, incorrect voltage control adjustment, or power supply failure. The protection circuit monitors the output and reduces the output voltage and current to zero whenever a preset voltage limit is exceeded. A TTL high signal on J3 PW17 indicates when the OVP circuit has been activated. Resetting the OVP circuit after activation requires removal of the over-voltage condition and powering the unit OFF and back ON or momentarily activating the remote shut down circuit (See Section 2.10 for information on shut down circuit operation). The OVP trip level can be set only using one of three remote programming methods (voltage, resistance or current) through the J3 connector at the rear of the unit. See Section 2.6.

### 2.9.1 Remote Programming of OVP With External Voltage Sources

To remotely program the OVP trip level using a 0-5V or 0-10V DC voltage source use the following procedure:

1. With the unit off and disconnected from its AC source, remove the cover and set switch SW1-4 closed (default factory setting) for 0-5V programming or open for 0-10V programming. Also check that switch SW1-8 is closed (default factory setting).
2. Remove the default jumper connecting pins 16 and 3 of connector J3 and connect the voltage source between pins 3 (positive) and 12 (negative). Set the programming source voltage to maximum.
3. Turn the unit on and adjust the output to the desired trip voltage (See Section 2.6.)
4. Slowly reduce the programming voltage until the red OVP indicator lamp lights and the power supply shuts down.
5. Turn the POWER switch to OFF.
6. Adjust the output voltage programming to minimum.
7. Turn the POWER switch back ON and increase the voltage to check that the power supply shuts off the output at the desired voltage.

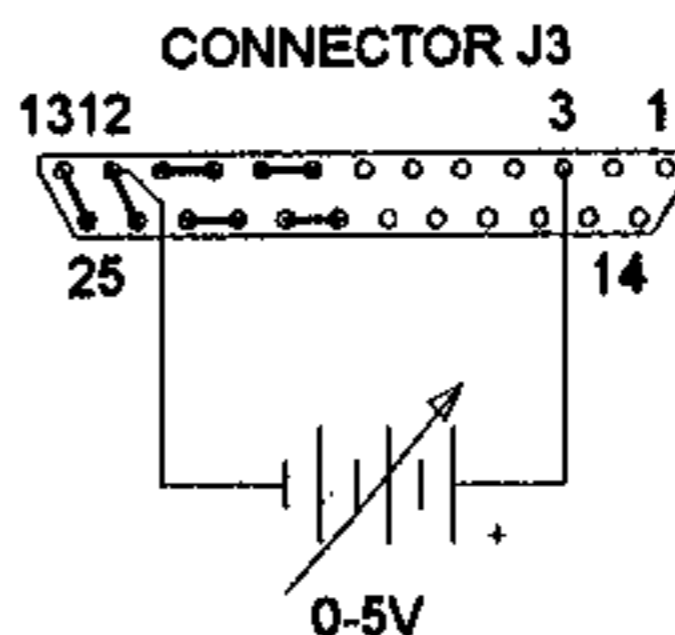
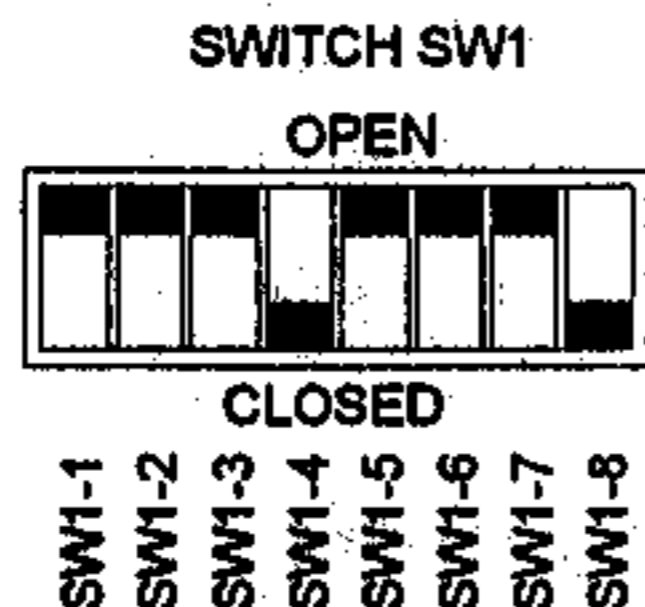

**Switch SW1**

- SW1-1 Off (Open)
- SW1-2 Off (Open)
- SW1-3 Off (Open)
- SW1-4 On (Closed)
- SW1-5 Off (Open)
- SW1-6 Off (Open)
- SW1-7 Off (Open)
- SW1-8 On (Closed)

**Switch SW1 and Connector J3 Configuration for 0-5Vdc OVP Programming**  
 (J3 sense line, voltage control and current control jumpers shown set for local operation.  
 Remote programming of output voltage not shown)

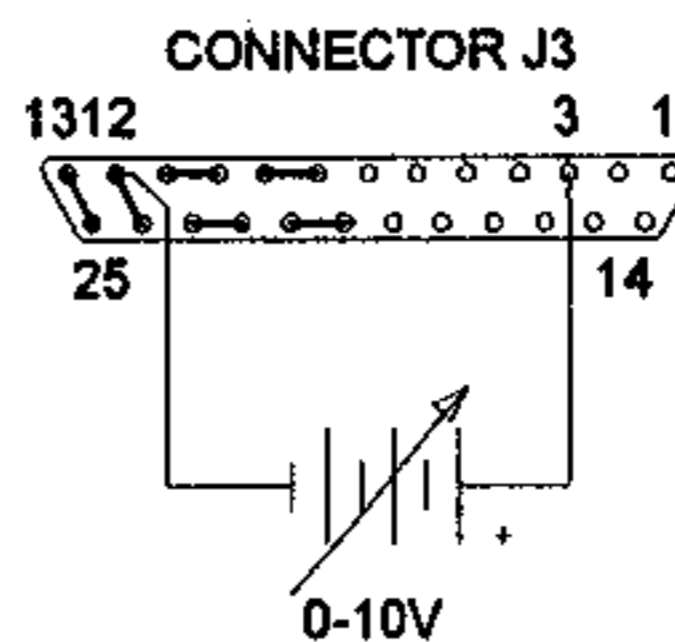
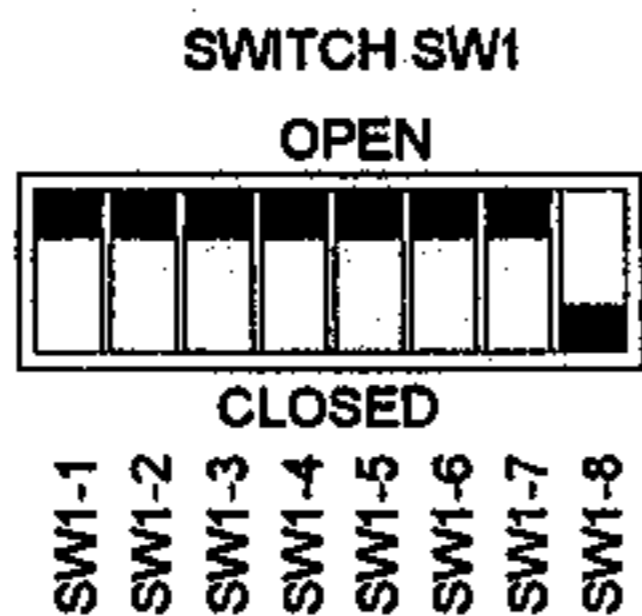

**Switch SW1**

- SW1-1 Off (Open)
- SW1-2 Off (Open)
- SW1-3 Off (Open)
- SW1-4 Off (Open)
- SW1-5 Off (Open)
- SW1-6 Off (Open)
- SW1-7 Off (Open)
- SW1-8 On (Closed)

**Switch SW1 and Connector J3 Configuration for 0-10Vdc OVP Programming**  
 (J3 sense line, voltage control and current control jumpers shown set for local operation.  
 Remote programming of output voltage not shown.)



**2.9.3 Remote Programming of OVP with an External Resistance**

To remotely program the OVP trip level using a 5k ohm external potentiometer use the following procedure.

1. With the unit off and disconnected from its AC source remove the cover, set switch SW1-8 open and check that switch SW1-4 is closed (default factory setting for switch SW1-4).
2. Connect the counterclockwise end of the 5k potentiometer to pins 3 and 16 of connector J3. Connect the tap and the clockwise end of the potentiometer to pin 12. Set the potentiometer fully clockwise.
3. Turn the unit on and adjust the output to the desired trip voltage.
4. Slowly turn the potentiometer counterclockwise until J3 pin 17 goes to a TTL high and the power supply shuts down.
5. Turn the POWER switch to OFF.
6. Adjust the output voltage programming to minimum.
7. Turn the POWER switch back ON and increase the voltage to check that the power supply shuts off the output at the desired voltage.

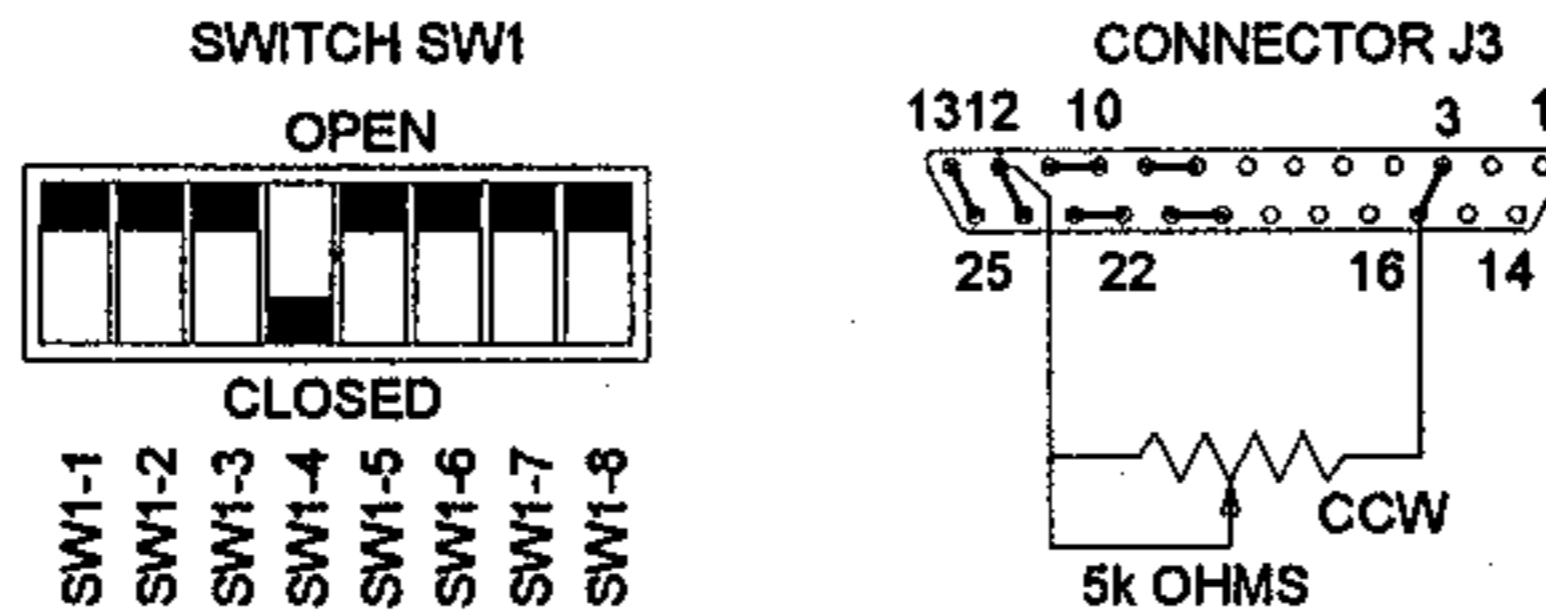

**Switch SW1**

SW1-1	Off (Open)
SW1-2	Off (Open)
SW1-3	Off (Open)
SW1-4	On (Closed)
SW1-5	Off (Open)
SW1-6	Off (Open)
SW1-7	Off (Open)
SW1-8	Off (Open)

**Switch SW1 and Connector J3 Configuration for 0-5k OVP Programming**  
 (J3 sense line, voltage control and current control jumpers shown set for local operation.  
 Remote programming of output voltage not shown.)



### 2.9.4 Remote Programming of OVP with External Current Sources

To remotely program the OVP trip level using a 0-1mA current source use the following procedure.

1. With the unit off and disconnected from its AC source remove the cover and set switches SW1-4 and SW1-8 closed (default factory setting).
2. Remove the default jumper connecting pins 16 and 3 of connector J3 and connect the current source between pins 3 (positive) and 12 (negative). Set the programming source to 1mA.
3. Turn the unit on and adjust the output to the desired trip voltage.
4. Slowly reduce the programming current until J3 pin 17 goes to a TTL high and the power supply shuts down.
5. Turn the POWER switch to OFF.
6. Adjust the output voltage programming to minimum.
7. Turn the POWER switch back ON and increase the voltage to check that the power supply shuts off the output at the desired voltage level.

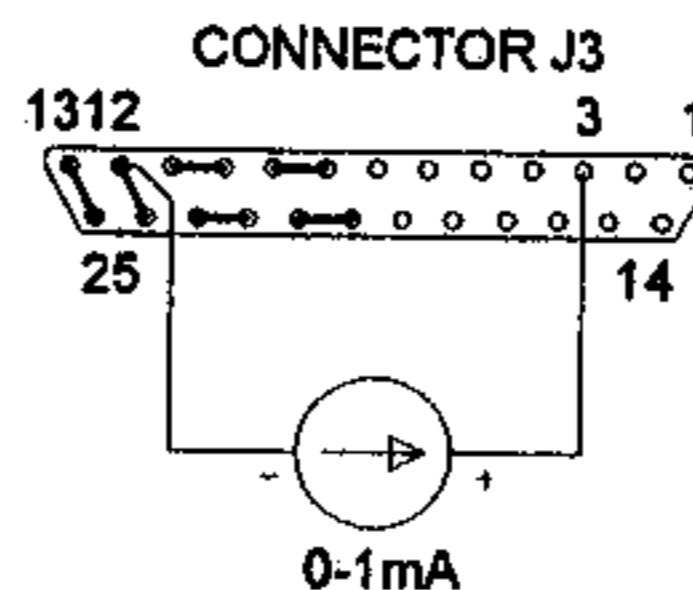
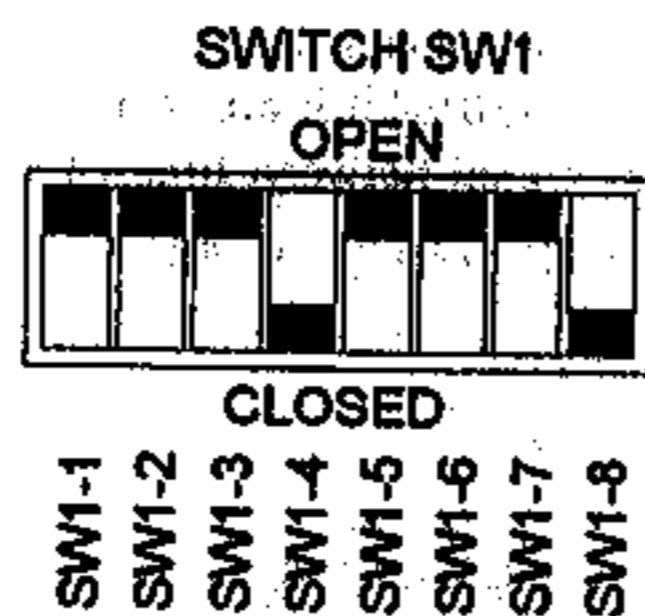

#### Switch SW1

SW1-1	Off (Open)
SW1-2	Off (Open)
SW1-3	Off (Open)
SW1-4	On (Closed)
SW1-5	Off (Open)
SW1-6	Off (Open)
SW1-7	Off (Open)
SW1-8	On (Closed)

**Switch SW1 and Connector J3 Configuration for 0-1mA Current Source OVP Programming**  
 (J3 sense line, voltage control and current control jumpers shown set for local operation.  
 Remote programming of output voltage not shown.)

### 2.9.5 Remote OVP Sensing

The default configuration for the OVP circuit senses the output voltage at the power supply output terminals. For applications using remote sensing where there is a need to accurately monitor the actual load voltage, the following procedure allows the OVP sense point to be shifted from the power supply output to the sense line connection points.

1. Shut the unit off and disconnect it from its power source. Remove the cover from the unit.
2. Using a sharp Exacto knife, cut the component side trace connecting the right hand side of resistor R89 to the via marked OVP-LOC.
3. Install an piece of insulated #22 AWG wire from the via marked C (near the trace cut just made) to the via marked C1 (near capacitor C51).
4. Reinstall the cover and reconnect the unit to its power source.

To return to local OVP sensing, remove the jumper installed in step 3 above and install a jumper across the trace cut made in step 2.

### 2.10 Remote ON/OFF

This feature is useful in test applications requiring remote ON-OFF control of the output. The remote ON-OFF control circuit uses either a TTL compatible or a 12-250Vac (or 12-130Vdc) input to remotely control (disable or enable) the power supply output. For TTL operation, a logic level signal between pins 14 (positive) and 2 (return) of connector J3 determines the output conditions:

TTL LOW = OUTPUT ON  
TTL HIGH = OUTPUT OFF

For AC or DC operation, an input of 12-250Vac (or 12-130Vdc) between pins 1 (positive for DC input) and 2 (return) of connector J3 will disable the output of the supply.

The input lines are optically isolated and can therefore be accessed by circuits with a voltage differential of up to 300Vdc with a maximum of 150 Vdc from safety ground.

#### 2.10.1 Remote ON/OFF by Contact Closure

An external relay may be used to operate the ON/OFF control circuit as follows. Connect one side of a normally open relay to pin 15 of connector J3 (+12V). Connect the other side of the relay to pin 14 (TTL Shutdown). Also connect J3 pin 2 (Shutdown return) to pin 6 (Ground). Using this configuration, the power supply will be OFF when the relay coil is energized and ON when the relay is de-energized.

If a normally closed relay is substituted for the normally open relay in the configuration described above, the power supply will be ON when the relay coil is energized and OFF when the relay is de-energized.

## 2.11 Remote Programming of Output Voltage and Current Limit

The output voltage and current limit of the power supply can be remotely programmed through the rear panel J3 connector using external voltage sources, current sources and resistances. Switch SW1 on the A2 printed circuit board controls the programming as diagrammed below.

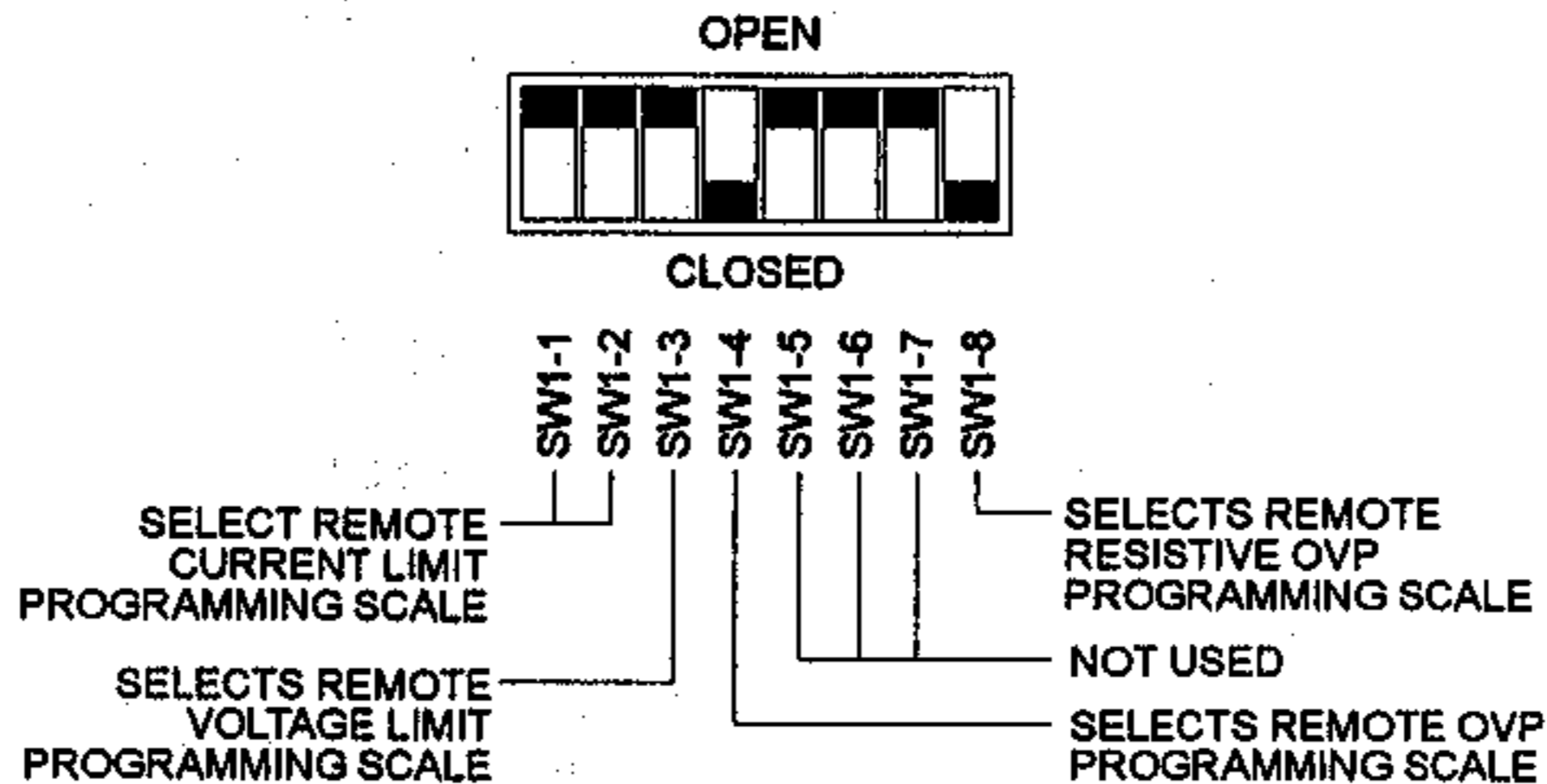

### Switch SW1

- SW1-1 Used to select 5V or 10V programming of remote current limit
- SW1-2 Used to select 100mV programming of remote current limit
- SW1-3 Used to select 5V or 10V programming of remote voltage limit
- SW1-4 Used to select remote OVP programming scale
- SW1-5 Not used
- SW1-6 Not used
- SW1-7 Not used
- SW1-8 Used to select remote resistive OVP programming scale

### Switch SW1 Functions

**Note:** To set switch SW1 shut the unit off, disconnect it from its AC source and remove the cover. Make the appropriate switch settings then reinstall the cover and reconnect the unit to its AC source.

**2.11.1 Programming With External Voltage Sources**

The output voltage can be programmed using either a 0-5Vdc or 0-10Vdc external voltage source. To program the output voltage with a 0-5Vdc source, set switch SW1-3 open (default factory setting) and remove the jumpers connecting pins 8 to 9 and 20 to 21 on connector J3. Connect the external source between pins 9 (positive) and 12 (return). Varying the external voltage from 0-5V will cause the output to vary from 0-100% of rated output.

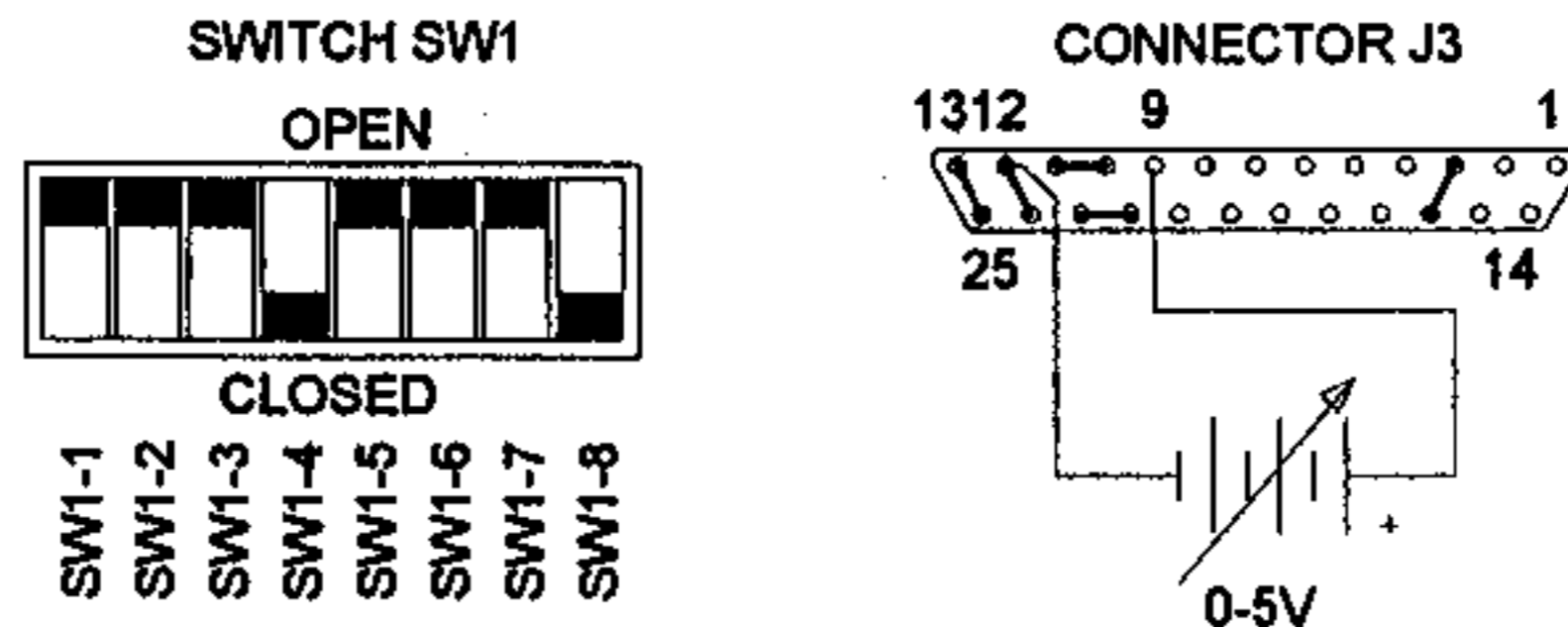

**Switch SW1**

SW1-1	Off (Open)
SW1-2	Off (Open)
SW1-3	Off (Open)
SW1-4	On (Closed)
SW1-5	Off (Open)
SW1-6	Off (Open)
SW1-7	Off (Open)
SW1-8	On (Closed)

**Switch SW1 and Connector J3 Configuration for 0-5V Programming of the Output Voltage**  
(J3 sense line, OVP and current control jumpers shown set for local operation)

For programming with a 0-10Vdc source, close switch SW1-3 and replace the 0-5V source with a 0-10V source.

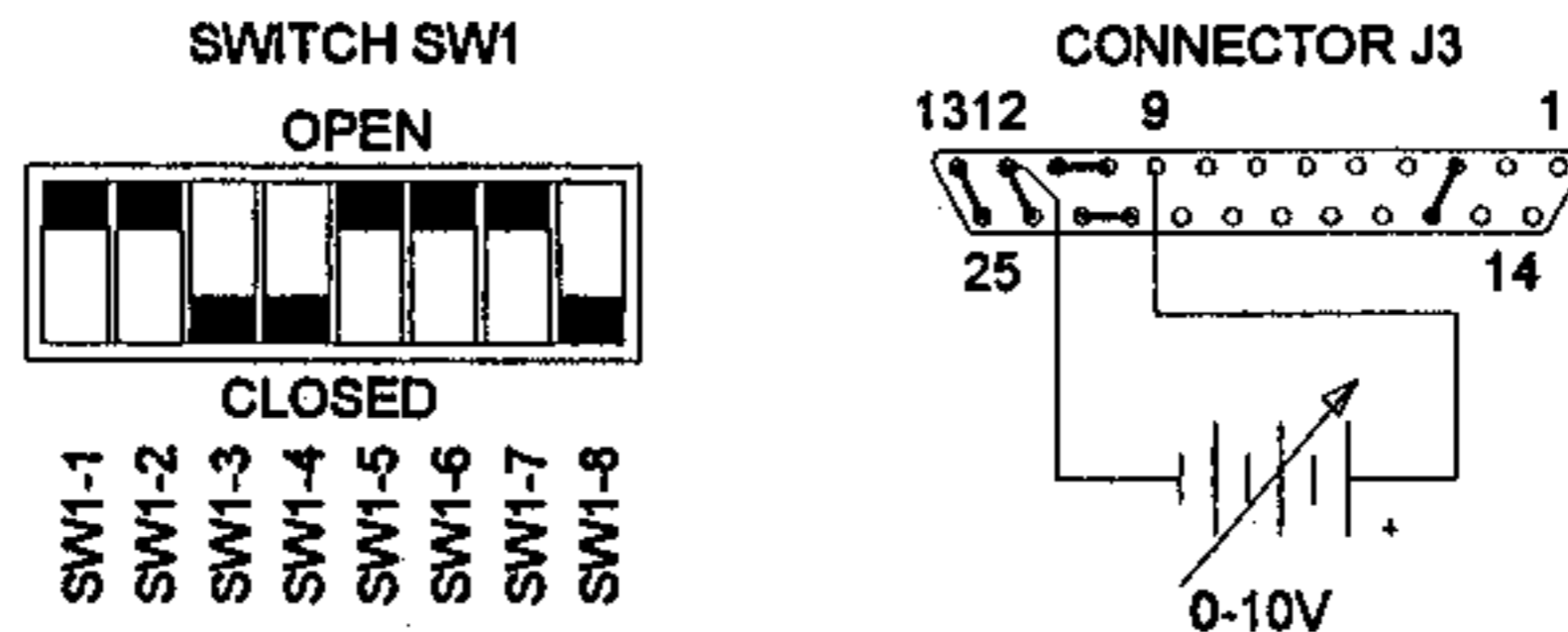

**Switch SW1**

SW1-1	Off (Open)
SW1-2	Off (Open)
SW1-3	On (Closed)
SW1-4	On (Closed)
SW1-5	Off (Open)
SW1-6	Off (Open)
SW1-7	Off (Open)
SW1-8	On (Closed)

**Switch SW1 and Connector J3 Configuration for 0-10V Programming of the Output Voltage**  
(J3 sense line, OVP and current control jumpers shown set for local operation)

The output current limit can be programmed using a 0-5Vdc or 0-10Vdc external voltage source. Selection of the programming voltage is done using switches SW1-1 and SW1-2 as indicated below:

SW1-1	SW1-2	PROGRAMMING VOLTAGE
OPEN	OPEN	0-5Vdc and Local Mode
CLOSED	CLOSED	Not Used
CLOSED	OPEN	0-10Vdc
OPEN	CLOSED	0-100mV

To remotely program the output current limit, set switches SW1-1 and SW1-2 as shown above, remove the jumpers connecting pins 10 to 11 and 22 to 23 of connector J3 and connect the external voltage source between pins 10 (positive) and 12 (return). Varying the voltage source from 0-100% causes the current limit to vary from 0-100% of the rated maximum.

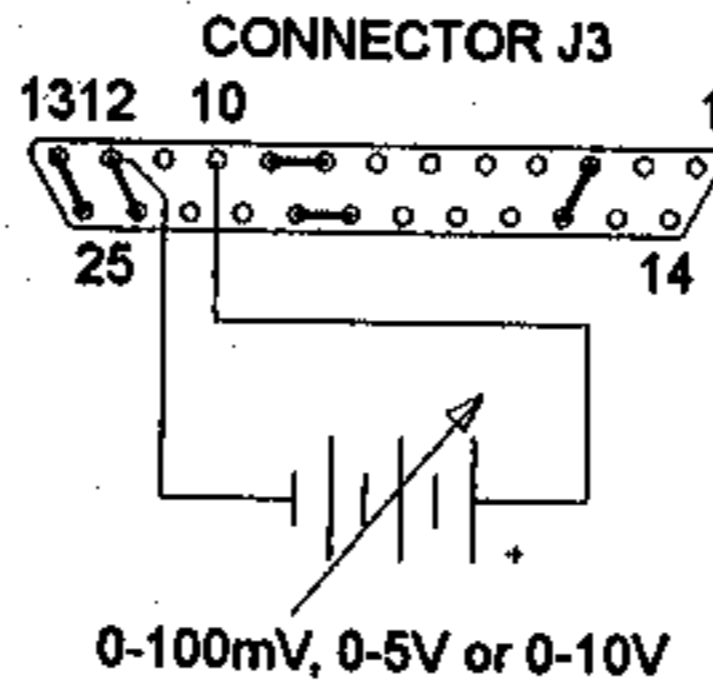

Connector J3 Configuration for Remote Programming of the Output Current Limit (J3 sense line, OVP and voltage control jumpers shown set for local operation)

### 2.11.2 Programming With an External Resistance

The output voltage and current limit can be programmed using a 5k ohm external potentiometer.

To program the output voltage, set switch SW1-3 open (default factory setting) and remove the jumpers connecting pins 8 to 9 and 20 to 21 on connector J3. Connect pins 9 and 21 to the counterclockwise end of the 5k potentiometer and connect the tap and clockwise end of the potentiometer to pin 12. Adjusting the tapped resistance from 0-5k will vary the output voltage from 0-100% of the rated output.

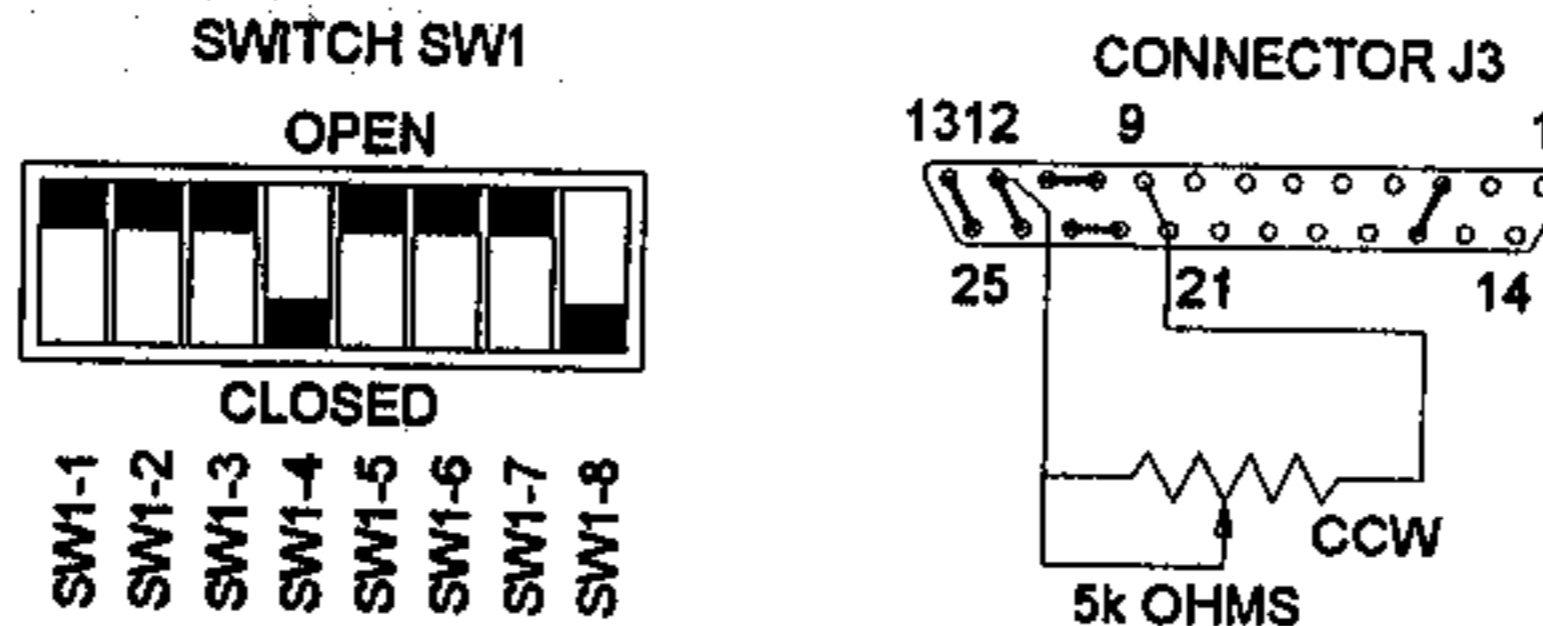

**Switch SW1**

- SW1-1 Off (Open)
- SW1-2 Off (Open)
- SW1-3 Off (Open)
- SW1-4 On (Closed)
- SW1-5 Off (Open)
- SW1-6 Off (Open)
- SW1-7 Off (Open)
- SW1-8 On (Closed)

**Switch SW1 and Connector J3 Configuration for Resistive Programming of the Output Voltage**  
 (J3 sense line, OVP and current control jumpers shown set for local operation)

To program the output current limit, set switches SW1-1 and SW1-2 open (default factory setting) and remove the jumpers connecting pins 10 to 11 and 22 to 23 on connector J3. Connect pins 10 and 22 to the counterclockwise end of the 5k potentiometer and connect the tap and clockwise end of the potentiometer to pin 12. Adjusting the tapped resistance from 0-5k will vary the current limit from 0-100% of the rated output.

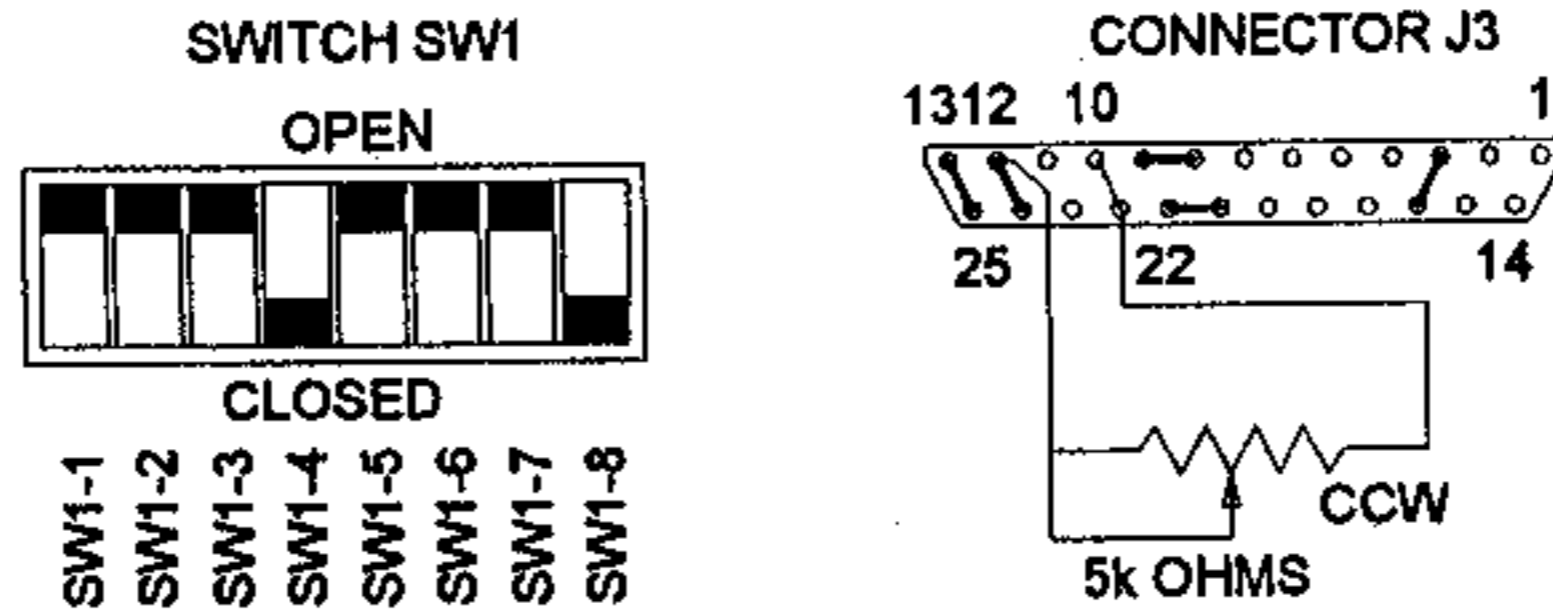

**Switch SW1**

- SW1-1 Off (Open)
- SW1-2 Off (Open)
- SW1-3 Off (Open)
- SW1-4 On (Closed)
- SW1-5 Off (Open)
- SW1-6 Off (Open)
- SW1-7 Off (Open)
- SW1-8 On (Closed)

**Switch SW1 and Connector J3 Configuration for Resistive Programming of the Output Current Limit**  
 (J3 sense line, OVP and voltage control jumpers shown set for local operation)



**2.11.3 Programming With an External Current Source**

The output voltage and current limit can be programmed using an external 0-1mA current source.

To program the output voltage, set the front panel voltage control to maximum, set switch SW1-3 open (default factory setting) and remove the jumper between pins 20 and 21 of connector J3. Connect the external current source between pins 8 (positive) and 12 (return) of connector J3. Varying the current source from 0-1mA will vary the output voltage from 0-100% of the rated output.

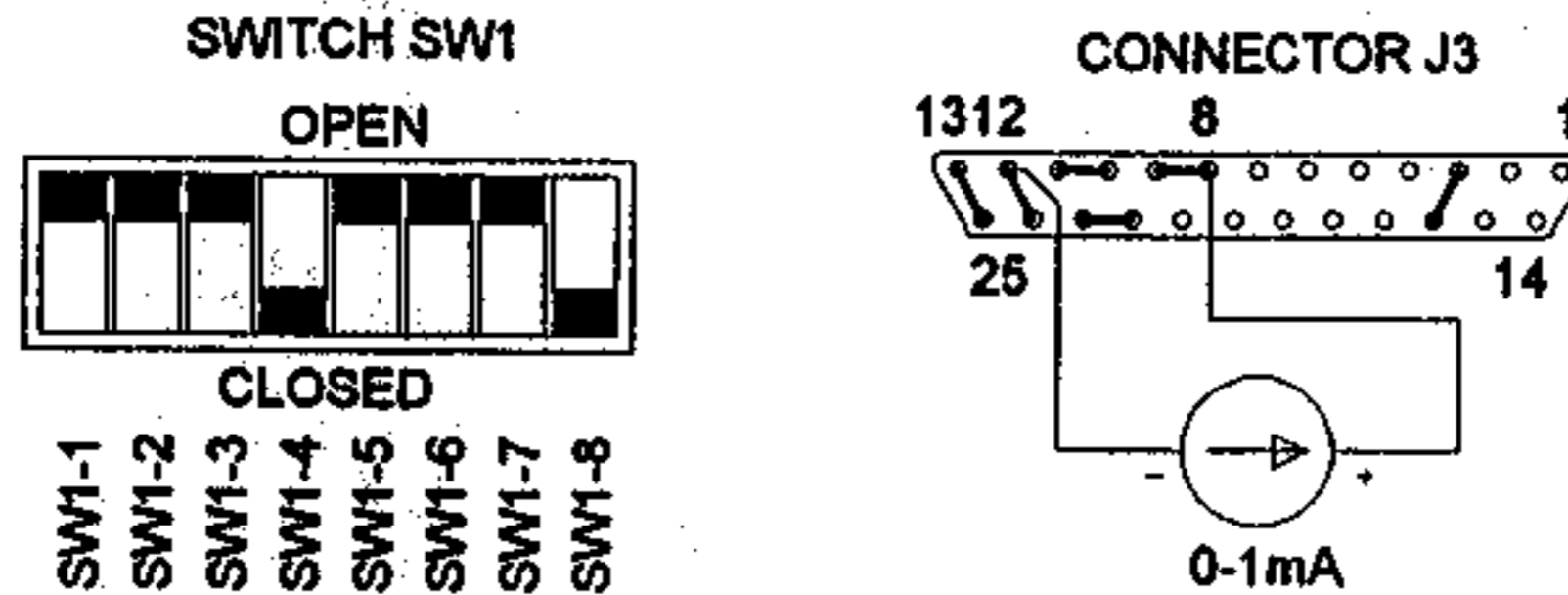

**Switch SW1 and Connector J3 Configuration for 0-1mA Current Programming of the Output Voltage**  
(J3 sense line, OVP and current control jumpers shown set for local operation)

To program the output current limit, set the current control to maximum, set switches SW1-1 and SW1-2 open (factory setting) and remove the jumper between pins 22 and 23 of connector J3. Connect the external current source between pins 11 (positive) and 12 (return). Varying the current source from 0-1mA causes the current limit to vary from 0-100% of rated maximum.

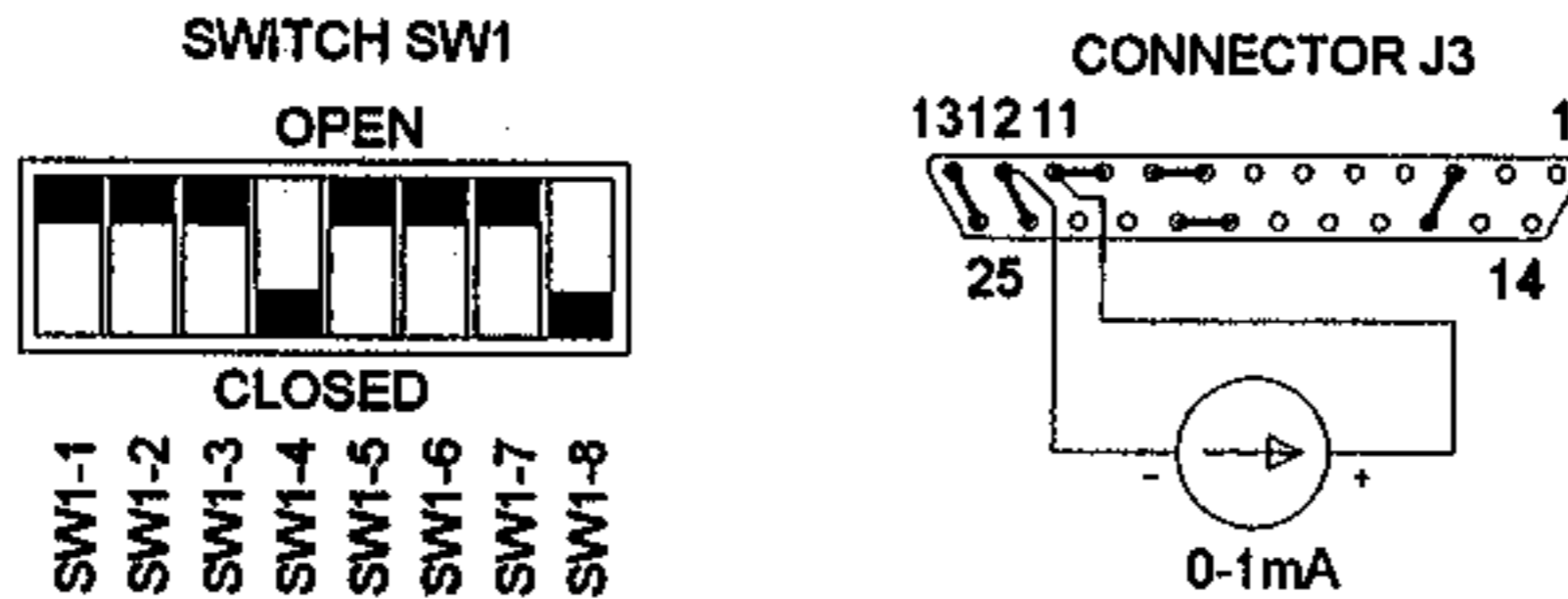

**Switch SW1 and Connector J3 Configuration for 0-1mA Current Programming of the Output Current Limit**  
(J3 sense line, OVP and voltage control jumpers shown set for local operation)

## 2.12 Remote Monitoring and Status Indicators

Readback signals for remote monitoring of the output voltage and current are available at connector J3 on the rear of the unit. A 0-5V (uncalibrated) signal between pins 19 (positive) and 12 (negative) represents 0-100% of the rated output voltage. A 0-5V (calibrated) signal between pins 7 (positive) and 12 (negative) represents 0-100% of the rated output current. The offset and gain of the current readback signal may be adjusted through holes in the cover of the unit (See Section 4.4 Calibration for location of adjusting holes).

Status indicators for thermal shutdown, OVP operation, remote programming and operating mode are also available through the J3 connector. The table below lists the various signals, the J3 connector pins where they are available, the approximate magnitude of the signal (measured with respect to pin 6 of connector J3) and the source impedance through which the signal is fed.

INDICATOR SIGNAL	J3 CONNECTOR PIN	SIGNAL VOLTAGE	SOURCE IMPEDANCE
Thermal Shutdown	18	+10V	750Ω
OVP Circuit Activated	17	+9V	750Ω
Remote Programming	4	+10V	750Ω
Voltage Mode Operation	5	+10V	750Ω
Current Mode Operation	5	-3V	750Ω

## SECTION 3. THEORY OF OPERATION

### 3.1 Power Circuit (A2 Assembly)

This section describes the operation of the A2 assembly switching regulator power circuit. Three subsections cover basic switching regulator theory, a simplified description of the Sorensen full bridge converter, and a more detailed circuit description intended for troubleshooting purposes.

#### 3.1.1 Basic Off-Line Switching Regulator Theory

An off-line switching power supply first converts the AC input line voltage to high voltage DC by diode rectification and then chops the DC at a high frequency. This high frequency waveform is applied to the primary of a power transformer which provides a step-up or step-down in voltage and electrical isolation on its secondary. The secondary waveform is rectified and filtered, giving a smooth DC output voltage. Feedback from the secondary circuit is applied to a pulse width modulator (PWM) control circuit which controls the on-time of the primary circuit switching waveform. This increases or decreases the voltage on the secondary of the power transformer so that output regulation is obtained.

The use of high frequency transformers in switching power supplies has the advantage of requiring less volume, less weight, and dissipating less heat than the lower frequency transformers in conventional linear power supplies.



#### **CAUTION!**

Potentially **LETHAL VOLTAGES** exist on the A2, A5, and A6 circuit boards on the primary side of the isolation barrier. Troubleshoot with care, preferably with power off and recognizing that filter capacitors store potentially **LETHAL** and **DESTRUCTIVE ENERGY** even for some time **AFTER POWER** is **REMOVED**. Always use an isolation transformer connected **ONLY** to the power supply input when making test measurements on the primary side circuits.

#### 3.1.2 Simplified Full Bridge Converter Theory

See Figure 3-1.

The input AC line voltage, both single-phase and three-phase, is rectified by the A6 board and filtered by C32 (A,B,C), and C72 (A,B,C) to a raw DC voltage which is supplied to the power FETs Q13-Q16 on the primary of power transformer T1. Resistor A6-R1 and relay K1 form an input surge current limiter which reduces the inrush current to the filter capacitors C32(A,B,C), and C72(A,B,C) during power-up. The power FETs and the primary winding of T1 form a bridge which is driven at 65 kHz by pulse width modulator (PWM) U6 through FETs Q7-Q12, Q18 and Q19 and drive transformer T2. A current sense transformer T3 in the primary of the power transformer provides a feedback signal to the PWM which is compared to a limited error signal derived from the output current and voltage control circuits. The output of the comparator controls the on time of the PWM output drive waveforms on a cycle by cycle basis thereby controlling the primary current and the output of the power transformer. Diodes CR301 and CR302 rectify the output of power transformer T1 and inductor L3 and capacitors C51, C52 and C53 filter the rectified signal to provide the DC output.

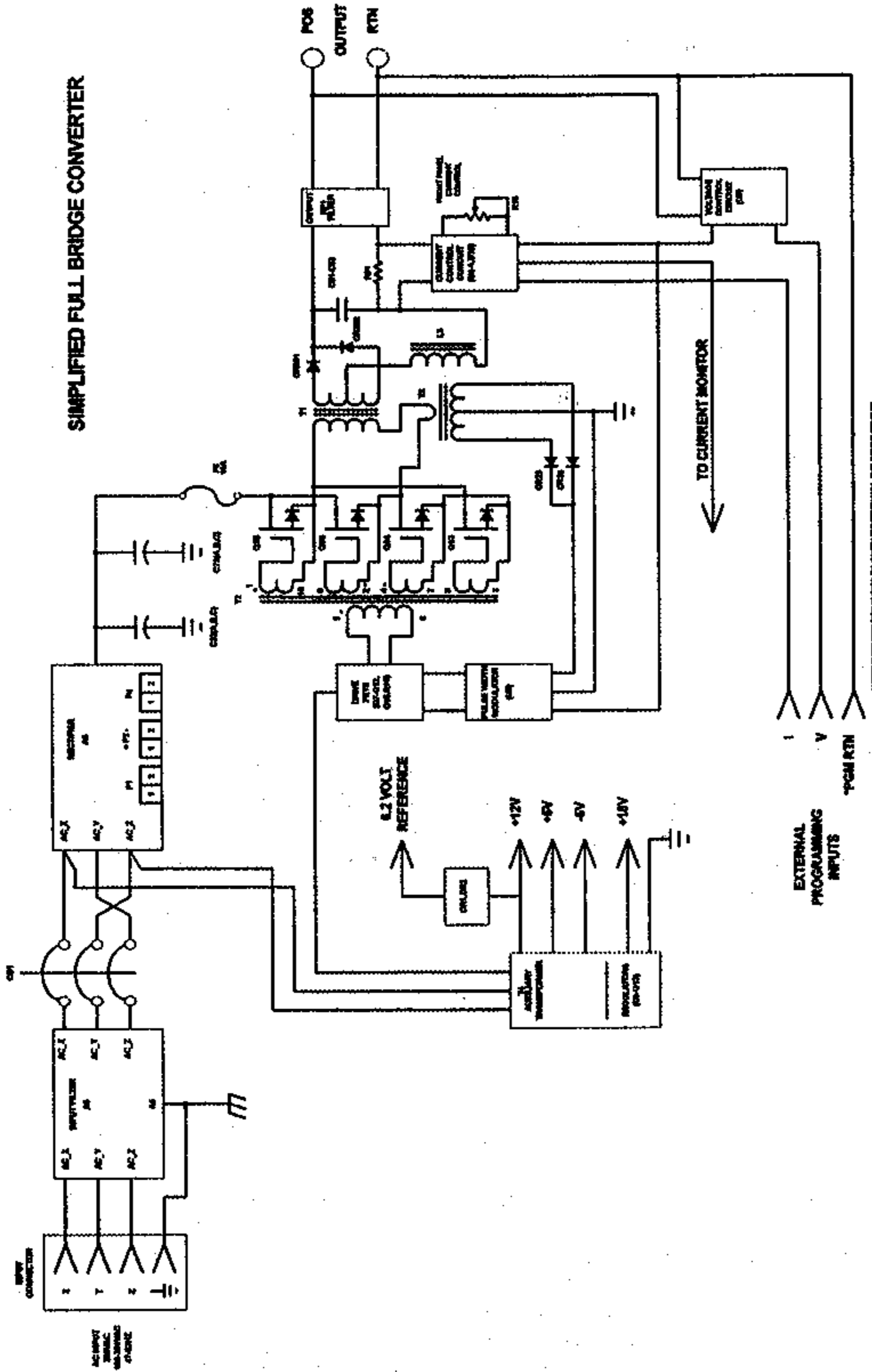

Figure 3-1

A current shunt (R91) in the output return line develops a voltage dependent on the output current. This current information is compared to the setting of the front panel current limit control in the current control circuit (U4-1 and U15). The output voltage is also monitored and compared to a fixed maximum voltage setting in the voltage control circuit (U5). The outputs of the voltage and current control circuits are OR'd and this signal is fed into the PWM error amplifier inverting input providing the negative feedback required to produce a regulated output. The output current information from the current control circuit is fed to the front panel output current monitor banana jacks.

Transformer T4, rectifier CR42 and regulators U9-U13 provide the necessary auxiliary supply voltages for the PWM circuit, the voltage and current control circuits, and the raw DC supply for drive transformer T2. A 6.2 volt reference is also derived from the 12V supply for use in metering circuits by diode CR1 and resistor R2.

Transformers T1, T3 and T4 provide output isolation from the line potentials in the primary circuit, the PWM circuit and the auxiliary supply circuits respectively.

### 3.1.3 Detailed Circuit Description

This section is intended to provide further detail for troubleshooting purposes. Please read the previous section as an overview and then refer to the detailed assembly schematic in Section 6.



#### **CAUTION!**

**Potentially LETHAL VOLTAGES exist on the A2, A5, and A6 circuit board on the primary side of the isolation barrier. Troubleshoot with care, preferably with power off and recognizing that filter capacitors store potentially LETHAL and DESTRUCTIVE ENERGY even for some time AFTER POWER is REMOVED. Always use an isolation transformer connected ONLY to the power supply input when making test measurements on the primary side circuits.**

#### AC Input and RFI Filter Circuit (A5 PCB)

The AC input is connected to the power supply via a four-pole connector in the rear panel. For three phase operation, three (3) phase lines, X, Y, and Z (190-250Vac at 14A), and a safety ground line are required. For single phase operation, two (2) phase lines (200-250Vac at 20A), and a safety ground line are required. Single phase input lines are connected to the X and Y inputs of the connector per customer requirement. Three 0.022mF Y-caps, one from each unit, X, Y, and Z, are connected to the chassis directly at the input for improved conducted EMI. The safety ground connection for both single and three phase operation is essential both to ensure that there is no shock hazard present and to ensure proper operation of the RFI filter and other bypass circuits.

The RFI filter, used to attenuate both common mode and differential mode noise, is an LC filter formed by X (line-to-line) capacitors C1-3 and C7-9, inductor L1, Y (line-to-ground) capacitors C4-6, and resistors R1-3 which serve as discharge resistors for the X capacitors.



### Input Rectifier and Inrush Limiting Circuit (A6 PCB)

The AC input is rectified by the chassis-mounted rectifiers CR2 and CR2A and then filtered by capacitors C32 (A, B, C) and C72 (A, B, C) on the A2 board to provide the raw high voltage DC (approximately 250-350V) for the main switching transistors and the A2 PCB auxiliary supply circuit. Resistor R2 provides a discharge path for capacitor C2 on power down. Capacitor provides noise filtering. The initial power up inrush current to capacitors C32 (A, B, C) and C72 (A, B, C) on the A2 board is limited by resistor R1.

The time delay for K1 contact closure is determined by the time constant formed by capacitor C12, resistor R118 and the gate threshold of FET Q6 located on the A2 board. Diode CR38 discharges C12 when the 12V auxiliary supply collapses and CR39 provides an inductive kickback path for the relay coil. During the inrush period diode CR33 holds the PWM shutdown line high, disabling the power supply output until Q6 turns on. Resistors R114 and R115 are bleeder resistors for the main filter capacitors. The rectified high voltage dc from CR2/CR2A is supplied to the main switching FETs Q13-Q16 on the primary of the power transformer T1 via fuse F3.

### Pulse Width Modulator

Pulse width modulator U6 is a current mode controller which drives the main switching FETs Q13-Q16 through drive FETs Q7-Q12, Q18 and Q19 and drive transformer T2. Capacitor C69 and resistors R111-R113 form a snubber on the primary of transformer T1 limiting switching transients. Transformer T3 is used to monitor T1 primary current and provide a feedback signal for the current sense amplifier of U6. Diodes CR29 and CR30 rectify T3 output while resistors R66 and R95-R97 and capacitors C60-C62 and C64A scale and condition the signal before it is input to the PWM. An internal PWM comparator compares the output of the current sense amplifier with a limited error signal derived from the output voltage and current control circuits. The output of the PWM comparator controls the pulse duration of the drive signals from pins 11 and 14 of the PWM thereby controlling the primary current in T1 and the output power. Resistor R100 and capacitor C63 set the internal oscillator of U6 to approximately 130kHz, resulting in a 65kHz output switching frequency. A 5.1V reference developed at pin 2 of the PWM is divided down by resistors R64 and R67 to provide a reference at the non inverting input of the PWM error amplifier (pin 5). The 5.1V reference voltage is also divided by resistors R65 and R68 to provide a reference at pin 1 of the PWM which limits the swing of the error amplifier output placing an upper limit on the primary current in transformer T1.

### Output Rectifier Circuit and Output Filter

A full wave center tap configuration is used for the output rectifier. The output rectifier is a one piece power tap unit mounted on the rectifier heatsink with the secondary snubber components connected directly to the rectifier input terminals. Capacitors C51-C53, power inductor L3 and common mode inductor L4 form the main output filter. On this model, the secondary filter capacitors C401-C407 are on a separate PCB which is mounted on the output bus bar assembly. Resistor R90 is an output pre-load which allows the unit to operate under no load or light load conditions.

Diodes CR301 and CR302 rectify the output of power transformer T1. Resistors R301-R304 and capacitors C301-C304 form snubbers on the secondary of T1 to limit switching transients while resistor R305 and capacitor C307 is used to provide additional rectifier snubbing.

### Voltage Control Circuit

The output voltage control circuit has been factory set to put out a maximum of 53V as the intended operation of the supply is as an adjustable current source only.

The output voltage is monitored by the voltage control op amp U5 at pin 3 via the positive sense line (pin 13 of connector J3) and the resistor divider formed by R21, R22, R53, and R85. This feedback voltage is compared with a 5V reference voltage, determined by the 1 mA current source through R98, into pin 2 of U5 by U7-2 to provide an error signal for the PWM. If the output voltage needs to be adjustable, then the jumper on J3 between pins 8 and 9 needs to be removed and an external adjustable 0-5 volt reference voltage input into J3 pin 9. Now if the output voltage tries to rise above the selected level, the voltage at pin 3 rises and the output of U5 becomes more positive. This increase is applied to the inverting input of the PWM error amplifier through diode CR18 and resistor R69 causing the amplifier output to decrease. This reduces the PWM output drive waveform pulse width, lowering the output voltage and regulating the output at the desired level. Similarly, if the output voltage tries to fall below the selected level the voltage at pin 3 decreases, U5 output decreases, the output from the PWM error amplifier increases and the drive waveform pulse width increases which raises the output voltage to the desired level. During voltage mode operation the output of the current control circuit at U4-1 pin 1 remains low. Resistor R70 and capacitor C54 provide compensation for the op amp and diode CR21A limits saturation. Capacitor C20, resistor R54 and CMOS gate U7-3 provide a soft start for the power supply during initial startup and recovery from shut down conditions by delaying the voltage rise at pin 2 of U5. Resistor R21 supplies a buffered 0-5V signal (uncalibrated) for remote monitoring of the output voltage which is provided at pin 19 of connector J3. Potentiometer R53 is used to adjust the full scale output of the power supply and potentiometer R52 is used to adjust the offset on op amp U5.

### Current Control Circuit

The output current is monitored by current shunt resistor R91 which develops a voltage across it proportional to the output current. This voltage is amplified and conditioned by the differential op amp U15 and associated components to provide a control ground referenced 0-2V signal at pin 3 of the current control op amp U4-1. This signal is compared to a reference signal gated from the front panel current control to pin 2 of U4-1 by U7-1. As the output current increases the voltage at pin 3 rises until it reaches the reference level set at pin 2 at which time the output of U4-1 goes high and the unit switches from voltage mode to current mode operation. The output current is maintained at the desired level by providing negative feedback to the PWM error amplifier as described in the voltage control circuit description above. Resistor R27 and capacitor C27 provide compensation for U4-1. Op amp U4-2 and related components scale the current feedback signal to provide a calibrated 0-10V output at pin 7 of connector J3 for external monitoring of the output current. An additional voltage divider consisting of R72, 73 is brought to the front panel monitor through J2-11. This is scaled for 4.0V at 38A output current.

### Auxiliary Supply and 6.2V Reference Circuit

Transformer T4, rectifier CR42 and capacitors C9 and C10 provide the raw dc supply voltages from which the +12V and +5V auxiliary supplies are derived by three terminal regulators U10 and U11 respectively. Two additional regulators (U12 and U13) provide the 12V feed to drive FETs Q7-Q12, Q18 and Q19 on the primary of T2, and the 12V feed to PWM U6. Diodes CR40 and CR41 with capacitors C7 and C11 provide the negative input to three terminal regulator U9 which supplies the -5V auxiliary output. Resistor R2 and Zener diode CR1 are used to derive a stable 6.2V reference from the +12V auxiliary supply for use on the front panel meters (via pin 5 of connector J1) and the A2 PCB. Transistor Q5, diode CR32, resistors R60-62 and Zener diode CR20 form a low voltage lock out which disables the power supply output by shutting down the PWM should the auxiliary raw supply fall below the threshold set by CR20.



### Voltage and Current Control Current Sources

Op amps U2-1 and U2-2, transistors Q1 and Q2, and related components are used to provide 1mA current sources for the front panel voltage and current controls. These current sources are also used for remote resistive programming of the output voltage and current limit.

### Over Voltage Protection Circuit

Op amp U3-1, transistor Q4 and related components provide a 1mA current source which is fed through R99 via the external jumper connecting pins 3 and 16 of connector J3, switch SW1-8 and pin 17 of connector J1. This current source provides reference at pin 6 of U3-2, the OVP control op amp which sets the maximum OVP trip point to about 55V. The power supply output voltage is monitored at pin 5 of U3-2 through the resistor divider formed by R80, R89 and R148. When the output voltage increases such that the voltage at pin 5 becomes higher than that at pin 6 the output of U3-2 goes high activating MOSFET Q17 (via drive FET Q2A) which clamps the power supply output off through resistor R93. Diode CR25 latches U3-2 on while diodes CR23 and CR24 gate the high signal to the shutdown pin of the PWM. The OVP may be reset by cycling the power switch off and then back on to release the latch provided by CR25 or by momentarily activating the remote shutdown circuit which causes pin 6 to be pulled high through diode CR10.

During remote voltage programming of the OVP trip level the internal 1mA current source is disconnected by removing the jumper connecting pin 3 and 16 of connector J3 and the reference voltage at pin 6 of U3-2 is provided directly by the external voltage source. Switch SW1-4 is used to select the programming range; 0-5V (with the switch closed) or 0-10V (with the switch open). For current programming the internal 1mA current source is replaced with a 0-1mA external source to provide the required 0-5V reference signal. For resistive programming switch SW1-8 is opened to disconnect the front panel adjusting potentiometer and the internal 1mA current source is connected to the external 0-5k ohm potentiometer to provide the 0-5V reference.

### Remote ON/OFF Circuit

A TTL high signal applied between pins 14 (positive) and 2 (negative) of connector J3 activates opto coupler U1 which turns on transistor switch Q3 by pulling its base low. This applies 12V through diode CR11 to the shutdown pin of the PWM thereby shutting down the power supply output. A 12-250Vac or 12-130Vdc signal applied between pins 1 (positive) and 2 (negative) of connector J3 will also activate U1 and disable the power supply output. Diode CR14 rectifies ac inputs while resistors R37 and R38 limit the current through the opto coupler. Diode CR13 provides protection against reverse polarity TTL signals.

### Remote Programming of the Output Voltage

During remote programming of the output voltage with an external voltage source (0-5V or 0-10V) the local operation jumpers connecting J3 pins 8 to 9 and 20 to 21 are removed and the external source is connected between pins 9 (positive) and 12 (negative) of connector J3. The input signal at J3 pin 9 is buffered via U14-2 to provide noise immunity. When using a 0-5V source the reference at pin 2 of U5 (voltage control op amp) is provided directly by the external source. When using a 0-10V source switch SW1-3 is closed to provide the necessary voltage divider to scale the reference voltage to 0-5V.

For remote programming with an external 5k resistance the jumpers connecting J3 pins 8 to 9 and 20 to 21 are removed, pins 9 and 21 are connected to the counterclockwise end of the external 5k ohm potentiometer and the tap and clockwise end are connected to pin 12. The internal 1mA current source at pin 21 develops a 0-5V potential across the potentiometer, depending on the potentiometer setting, which is fed to pin 2 of U5.

During remote programming of the output voltage with an external 0-1mA current source the jumper connecting J3 pins 20 and 21 is removed, the front panel voltage control is set fully clockwise and the external current source is connected between pins 8 (positive) and 12 (return). Varying the current source from 0-1mA causes 0-5V to develop at the reference pin of the voltage control circuit.

#### Remote Programming of the Output Current Limit

During remote programming of the output current limit with an external voltage source the local operation jumpers connecting J3 pins 10 to 11 and 22 to 23 are removed and the external source (0-100mV, 0-5V or 0-10V) is connected between pins 10 (positive) and 12 (negative). The input signal at J3 pin 10 is buffered via U14-1 to provide noise immunity. When using a 0-5V source the reference at pin 2 of U4-1 (current control op amp) is provided by the external source and divided down to a 0-2V reference by R20 and R146. Use of a 0-10V source requires that switch SW1-1 be closed to add R5 to the voltage divider to limit the control circuit reference voltage to 0-2V. For 0-100mV, programming switch SW1-1 is opened and switch SW1-2 is closed, changing U14-1 from a voltage follower to an amplifier by virtue of feedback resistor R150 and voltage divider resistor R50.

For remote programming with an external 5k resistance the jumpers connecting J3 pins 10 to 11 and 22 to 23 are removed, pins 10 and 22 are connected to the counterclockwise end of the external 5k ohm potentiometer and the tap and clockwise end are connected to pin 12. The internal 1mA current source at pin 22 develops a 0-5V potential across the potentiometer, depending on the potentiometer setting, which is fed to pin 6 of U4-2.

During remote programming of the output voltage with an external 0-1mA current source the jumper connecting J3 pins 22 and 23 is removed, the front panel voltage control is set fully clockwise and the external current source is connected between pins 11 (positive) and 12 (return). Varying the current source from 0-1mA causes 0-5V to develop at the reference pin of the current control circuit.

**This page intentionally left blank.**

## SECTION 4. MAINTENANCE, TROUBLESHOOTING, AND CALIBRATION

### 4.1 General

This section provides periodic maintenance, calibration and troubleshooting information.

### 4.2 Periodic Service

No routine service except for periodic cleaning is required. Whenever a unit is removed from service, it should be cleaned, using denatured or isopropyl alcohol or an equivalent solvent on the metal surfaces and a weak solution of soap and water for the front panel. Low pressure compressed air may be used to blow dust from in and around components on the printed circuit boards.

### 4.3 Troubleshooting

Units requiring repair during their warranty period should be returned to Sorensen for service. Unauthorized repairs performed by anyone other than Sorensen Company during the warranty period may void the warranty. Any questions regarding repair should be directed to the Service Department, Sorensen Company, Division of Elgar Company.



**CAUTION!**

**POTENTIALLY LETHAL VOLTAGES EXIST IN THE POWER CIRCUIT.** Filter capacitors store potentially dangerous energy for some time after power is removed. Repairs should be attempted by experienced technical personnel only. Be sure to isolate the power supply from the input line with an isolation transformer when using grounded test equipment such as an oscilloscope in the power circuit.

#### 4.3.1 Preliminary Checks

If the power supply displays any unusual or erratic operation shut the power supply off immediately and disconnect it from the AC power source. Check all load, programming and monitoring connections and circuits. Check the AC input for correct voltage and frequency. Correct any problems found and retest the system. If no problems are found or the unit fails to operate correctly upon retesting proceed with internal troubleshooting as described below.

**4.3.2 Internal Troubleshooting** 

After reading the caution in Section 4.3 and completing the preliminary checks described in Section 4.3.1, remove the cover and proceed with internal troubleshooting using the information contained in Figure 4-1 as a guide to isolate the problem to a specific area of the circuit. Refer to the schematics in Section 6 and the theory of operation in Section 3 for additional information.

**4.4 Calibration**

Calibration on the A2 assembly is accomplished using multiturn trim pots. The list below provides the circuit designation of the trim pot and the parameter affected by that part. Calibration is performed at the factory during testing, and recalibration should be unnecessary unless major repairs are required. Calibration can be accomplished only with the cover removed.

CIRCUIT DESIGNATION	ASSEMBLY	PARAMETER AFFECTED
R7	A2	Output Current Monitor Calibration
R46	A2	Output Current Monitor Offset
R47	A2	Current Control Circuit Offset
R48	A2	Output Current Range
R52	A2	Voltage Control Circuit Offset
R53	A2	Output Voltage Range
R8	M15 Option Board	Program Range Adjust
R11	M15 Option Board	Program Offset Adjust

**NOTE:** Consult the factory for full calibration requirements.

**TROUBLESHOOTING GUIDE**  
**CAUTION**

READ THE FOLLOWING INSTRUCTIONS AND PERFORM

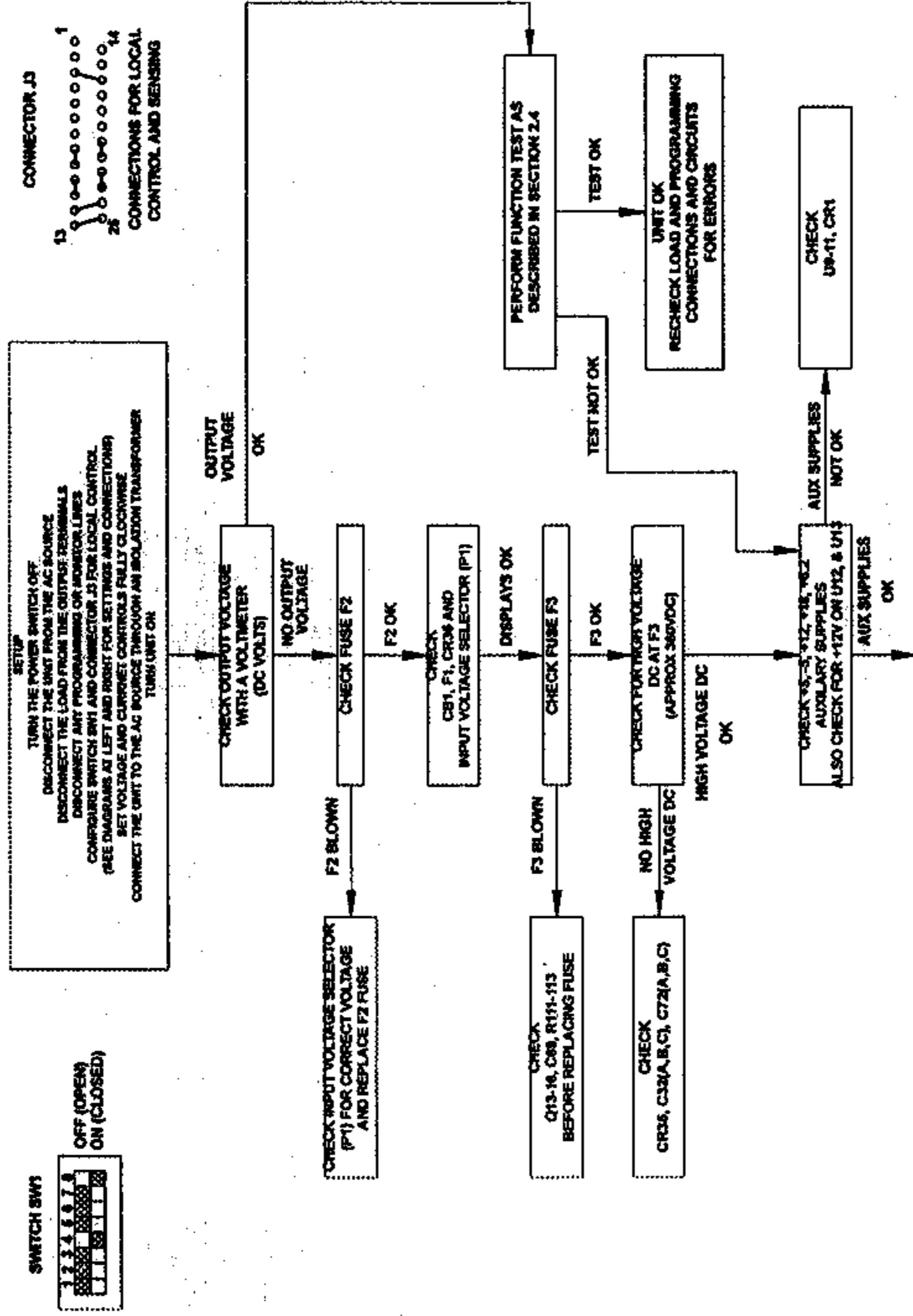

To Figure 4-1B

Figure 4-1A



From Figure 4-1A

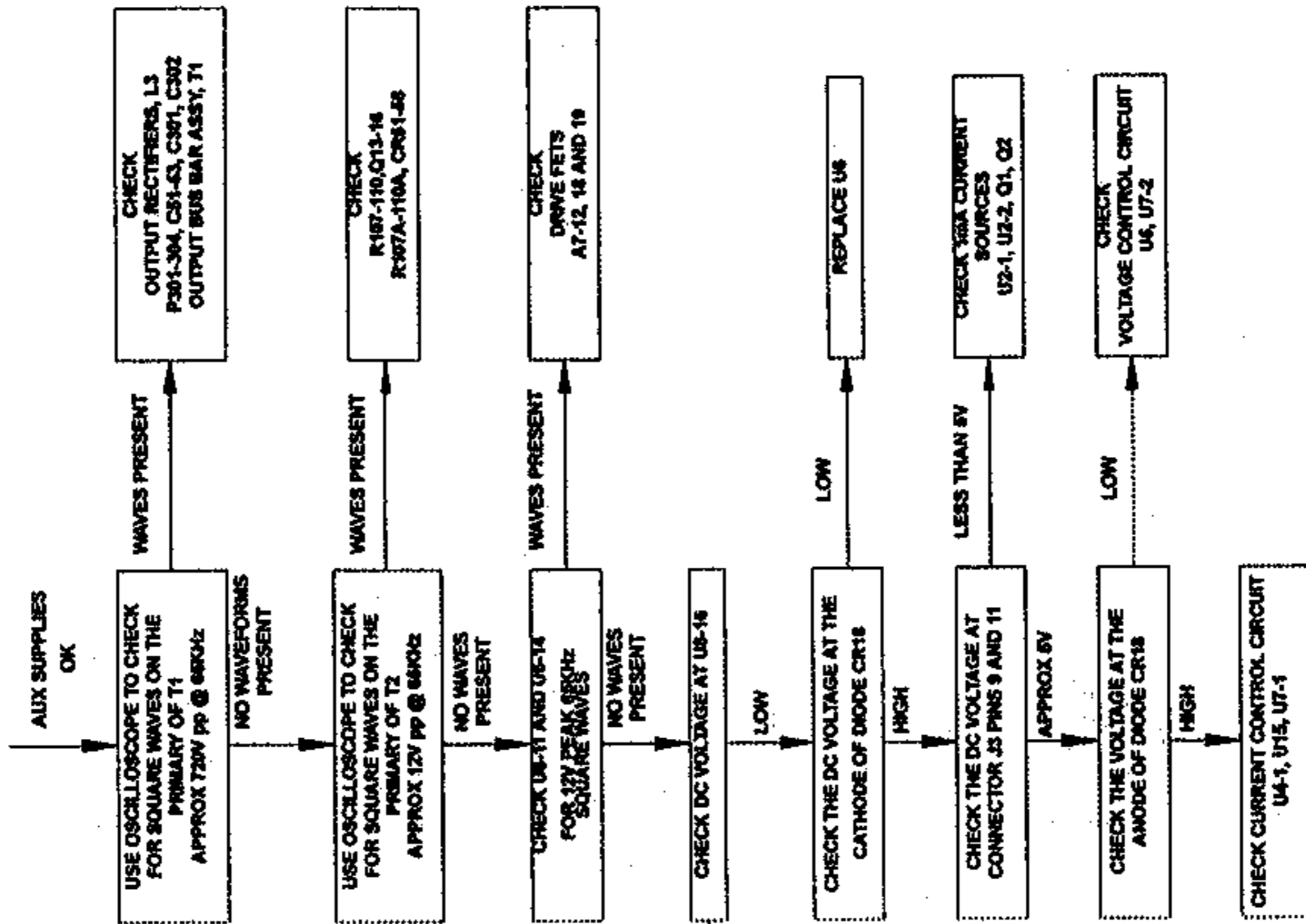

**CAUTION**

MAKE OSCILLOSCOPE CONNECTIONS WITH THE UNIT SHUT OFF ENSURE THAT THE UNIT IS ISOLATED FROM THE AC LINE OF DAMAGE TO UNIT AND/OR TEST EQUIPMENT MAY RESULT

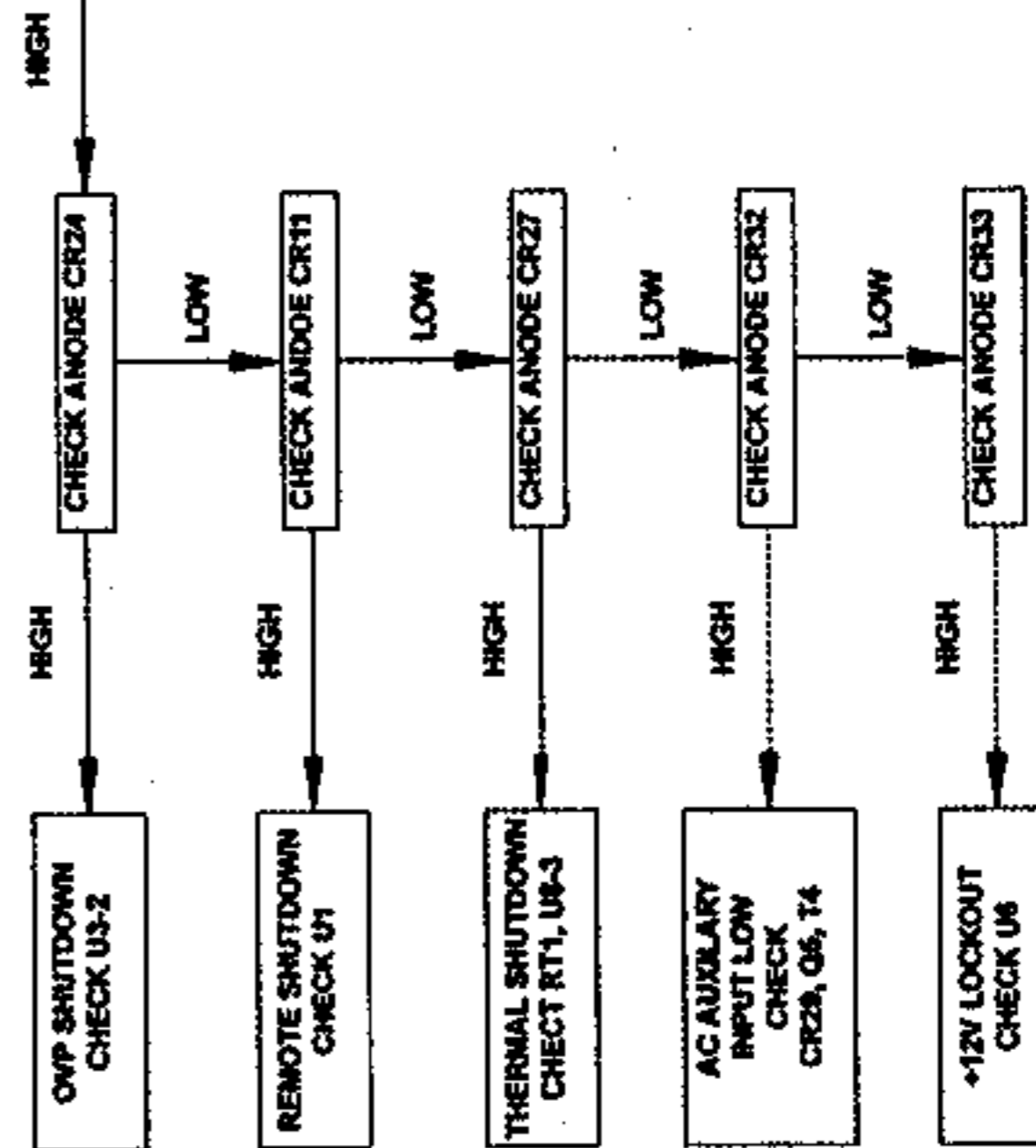

Figure 4-1B