

*DLM-E*  
*3kW & 4kW Series*  
*Power Supplies*

**Operation Manual**

This manual covers models:

DLM5-350E	DLM5-450E
DLM8-350E	DLM8-450E
DLM16-185E	DLM16-250E
DLM32-95E	DLM32-125E
DLM40-75E	DLM40-100E
DLM60-50E	DLM60-66E
DLM80-37E	DLM80-50E
DLM150-20E	DLM150-26E
DLM300-10E	DLM300-13E
DLM600-5E	DLM600-6.6E

SORENSEN

**9250 Brown Deer Road**  
**San Diego, CA 92121-2294**  
**1-800-733-5427**  
**Tel: (858) 450-0085**  
**Fax: (858) 458-0267**  
**Email: [sales@elgar.com](mailto:sales@elgar.com)**  
**[www.elgar.com](http://www.elgar.com)**

©2002 by Sorensen, Division of Elgar Electronics Corporation

This document contains information proprietary to Sorensen, division of Elgar Electronics Corporation. The information contained herein is not to be duplicated or transferred in any manner without prior written permission from Sorensen.



Offered to you with pride by

# The DLM Development Team

A Hector Cealillo

Norm Proctor Don Javel

Sharon Montgomery  
Maxia Michel

Juanita M. Trice

Alicia Garcia

S. Pope

Paul Marshall

Chucell

# SORENSEN

W.D.

Quang H.

Rebecca Hunt

Eric Bryan

John Fogh

Donna Scheinhor

Hortencia Castillo

[Signature]

Leann Jones

Dave Rullo

[Signature]

Yolande C. Turner

Juliana Salas  
Maura E. Kennedy

Randy Warner

Frog Bailey

Amad Sanchez

[Signature]

Tom Baker



## SAFETY NOTICE

---

Before applying power to the system, verify that the power supply is configured properly for the user's particular application.



### WARNING!

**HAZARDOUS VOLTAGES IN EXCESS OF 280 VRMS, 600V PEAK MAY BE PRESENT WHEN COVERS ARE REMOVED. QUALIFIED PERSONNEL MUST USE EXTREME CAUTION WHEN SERVICING THIS EQUIPMENT. CIRCUIT BOARDS, TEST POINTS, AND OUTPUT VOLTAGES MAY BE FLOATING ABOVE (BELOW) CHASSIS GROUND.**

Installation and service must be performed by qualified personnel who are aware of dealing with attendant hazards. This includes such simple tasks as fuse verification.

**Ensure that the AC power line ground is connected properly to the unit input connector or chassis. Similarly, other power ground lines including those to application and maintenance equipment must be grounded properly for both personnel and equipment safety.**

Always ensure that facility AC input power is de-energized prior to connecting or disconnecting the input/output power cables.



During normal operation, the operator does not have access to hazardous voltages within the chassis. However, depending on the user's application configuration, HIGH VOLTAGES HAZARDOUS TO HUMAN SAFETY may be generated normally on the output terminals. Ensure that the output power lines are labeled properly as to the safety hazards and that any inadvertent contact with hazardous voltages is eliminated. To guard against risk of electrical shock during open cover checks, do not touch any portion of the electrical circuits. Even when the power is off, capacitors can retain an electrical charge. Use safety glasses during open cover checks to avoid personal injury by any sudden failure of a component.

Due to filtering, the unit has high leakage current to the chassis. Therefore, it is essential to operate this unit with a safety ground.

**Some circuits are live even with the front panel switch turned off. Service, front panel filter removal (if applicable), fuse verification, and connection of wiring to the chassis must be accomplished at least five minutes after power has been removed via external means; all circuits and/or terminals to be touched must be safety grounded to the chassis.**

After the unit has been operating for some time, the metal near the rear of the unit may be hot enough to cause injury. Let the unit cool before handling.

Qualified service personnel need to be aware that some heat sinks are not at ground, but at high potential.

These operating instructions form an integral part of the equipment and must be available to the operating personnel at all times. All the safety instructions and advice notes are to be followed.

Neither Sorensen, San Diego, California, USA, nor any of the subsidiary sales organizations can accept any responsibility for personal, material or consequential injury, loss or damage that results from improper use of the equipment and accessories.

## SAFETY SYMBOLS



CAUTION  
Risk of Electrical Shock



CAUTION  
Refer to Accompanying Documents



Off (Supply)



Direct Current (DC)



Standby (Supply)



Alternating Current (AC)



On (Supply)



Three-Phase Alternating Current



Protective Conductor Terminal



Earth (Ground) Terminal



Fuse



Chassis Ground

## SORENSEN FIVE-YEAR WARRANTY

---

Sorensen, a division of Elgar Electronics Corporation, warrants its products to be free from defects in material and workmanship. This warranty is effective for five years from the date of shipment of the product to the original purchaser. Liability of Sorensen under this warranty shall exist provided that:

- the Buyer exposes the product to normal use and service and provides normal maintenance on the product;
- Sorensen is promptly notified of defects by the Buyer and that notification occurs within the warranty period;
- the Buyer receives a Return Material Authorization (RMA) number from Sorensen's Repair Department prior to the return of the product to Sorensen for repair, phone 800-458-4258;
- the Buyer returns the defective product in the original, or equivalent, shipping container;
- if, upon examination of such product by Sorensen it is disclosed that, in fact, a defect in materials and/or workmanship does exist, that the defect in the product was not caused by improper conditions, misuse, or negligence; and,
- that Sorensen QA seal and nameplates have not been altered or removed and the equipment has not been repaired or modified by anyone other than Sorensen authorized personnel.

This warranty is exclusive and in lieu of all other warranties, expressed or implied, including, but not limited to, implied warranties of merchantability and fitness of the product to a particular purpose. Sorensen, its agents, or representatives shall in no circumstance be liable for any direct, indirect, special, penal, or consequential loss or damage of any nature resulting from the malfunction of the product. Remedies under this warranty are expressly limited to repair or replacement of the product.

### CONDITIONS OF WARRANTY

- To return a defective product, contact a Sorensen representative or the Sorensen factory for an RMA number. Unauthorized returns will not be accepted and will be returned at the shipper's expense.
- For Sorensen products found to be defective within thirty days of receipt by the original purchaser, Sorensen will absorb all ground freight charges for the repair. Products found defective within the warranty period, but beyond the initial thirty-day period, should be returned prepaid to Sorensen for repair. Sorensen will repair the unit and return it by ground freight pre-paid.
- Normal warranty service is performed at Sorensen during the weekday hours of 7:30 am to 4:30 pm Pacific time. Warranty repair work requested to be accomplished outside of normal working hours will be subject to Sorensen non-warranty service rates.
- Warranty field service is available on an emergency basis. Travel expenses (travel time, per diem expense, and related air fare) are the responsibility of the Buyer. A Buyer purchase order is required by Sorensen prior to scheduling.
- A returned product found, upon inspection by Sorensen, to be in specification is subject to an inspection fee and applicable freight charges.
- Equipment purchased in the United States carries only a United States warranty for which repair must be accomplished at the Sorensen factory.

**Sorensen**

*Committed to Quality...Striving for Excellence*

## ABOUT THIS MANUAL

---

This manual has been written expressly for the Sorensen DLM-E 3kW and 4kW series of power supplies, which have been designed to meet the 1997 Low Voltage and Electromagnetic Compatibility Directive Requirements of the European Community.

Since the goal of the Low Voltage Directive is to ensure the safety of the equipment operator, universal graphic symbols (see Safety Notice above) have been used both on the unit itself and in this manual to warn the operator of potentially hazardous situations.

# CONTENTS

Safety Notice .....	i
Warranty .....	iii
<b>SECTION 1 FEATURES AND SPECIFICATIONS .....</b>	<b>1</b>
1.1 Description.....	1
1.2 Operating Modes .....	1
1.3 Power Supply Features .....	1
1.4 Specifications.....	3
1.4.1 3 kW DLM–E Electrical Specifications.....	3
1.4.2 4 kW DLM–E Electrical Specifications.....	4
1.4.3 Additional Specifications.....	5
1.4.4 Mechanical Specifications .....	6
<b>SECTION 2 INSTALLATION .....</b>	<b>7</b>
2.1 Introduction.....	7
2.2 Safety.....	7
2.2.1 High Energy/High Voltage Warning.....	7
2.2.2 AC Source Grounding .....	8
2.2.3 EMI Provisions.....	8
2.2.4 Operating and Servicing Precautions .....	9
2.2.5 Parts and Modifications .....	9
2.3 Initial Inspection .....	9
2.3.1 Physical Check .....	9
2.4 Controls, Connectors, and Indicators .....	10
2.4.1 Front Panel User Controls and Indicators .....	10
2.4.2 Rear Panel.....	13

2.5	Location, Mounting, and Ventilation .....	14
2.5.1	Unit Dimensions .....	14
2.5.2	Rack Mounting .....	14
2.5.3	Ventilation .....	14
2.6	AC Input Power Connection .....	15
2.6.1	AC Input Power Requirements.....	15
2.6.2	Input Line Impedance .....	15
2.7	Initial Functional Tests .....	16
2.8	Load Connection .....	16
2.8.1	Load Conductor Ratings .....	17
2.8.2	Noise and Impedance Effects .....	17
2.8.3	Making the Connections .....	18
2.8.4	Connecting Single Loads .....	18
2.8.5	Connecting Multiple Loads.....	19
SECTION 3 BASIC OPERATION .....		21
3.1	Introduction .....	21
3.2	Standard Operation.....	21
3.2.1	Operating Modes and Automatic Crossover .....	21
3.2.2	Local Programming Mode Operation .....	23
3.3	Using Remote Sensing .....	24
3.3.1	Connecting Remote Sense Lines .....	24
SECTION 4 ADVANCED OPERATION .....		27
4.1	Introduction .....	27
4.2	Configuring for Remote Programming, Sensing, and Monitoring .....	28
4.2.1	Programming, Monitoring, and Control Functions.....	28
4.2.2	Rear Panel DIP Switch .....	29
4.2.3	Resetting Rear Panel DIP Switch Settings .....	30
4.2.4	Making J3 Connections.....	30
4.3	Remote Programming of Output Voltage and Current Limit .....	31
4.3.1	Programming Output Voltage and Current Limit with the REMOTE/LOCAL Switch .....	32
4.3.2	Programming Output Voltage.....	33
4.3.3	Programming Output Current Limit .....	35
4.3.4	Remote Programming Only the Output Voltage or Current Limit.....	37

4.4	Using Over Voltage Protection (OVP) .....	39
4.4.1	Front Panel OVP Operation.....	39
4.4.2	Resetting the OVP Circuit.....	39
4.4.3	Programming OVP with an External Voltage Source .....	40
4.5	Using the Shutdown Function.....	42
4.5.1	STANDBY Switch .....	42
4.5.2	Programming the Shutdown Function .....	42
4.5.3	Shutdown Application – Contact Closure .....	43
4.6	Remote Monitoring .....	45
4.6.1	Readback Signals.....	45
4.6.2	Status Indicators.....	46
4.7	Using Multiple Supplies .....	46
4.7.1	Configuring Multiple Supplies for Series Operation.....	46
4.7.2	Configuring Multiple Supplies for Split Supply Operation .....	47
4.7.3	Configuring Multiple Supplies for Parallel Operation .....	49
4.8	Front Panel Lockout.....	50
SECTION 5 MAINTENANCE AND TROUBLESHOOTING .....		51
5.1	Periodic Service.....	51
5.2	Troubleshooting.....	51
5.2.1	Preliminary Checks.....	51
5.2.2	Troubleshooting at the Operation Level .....	52
5.3	Calibration.....	53
5.4	Ordering Parts .....	54
5.5	Fuse Ratings.....	54
LIST OF TABLES		
Table 4–1. J3 Connector – Program, Control, and Monitor Description .....		29
Table 4–2. Rear Panel S1 DIP Switch Functions and Settings .....		30
Table 4–3. J12, J13 Connectors–Parallel Port Function and Pinout .....		49
Table 5–1. User Diagnostics .....		52
Table 5–2. Potentiometer Adjustment Procedures.....		53
Table 5–3. Fuse Ratings .....		54

## LIST OF FIGURES

Figure 2–1. EMI Suppression Filter.....	8
Figure 2–2. DLM–E Controls, Connectors, and Indicators (5V–80V models) .....	11
Figure 2–3. DLM–E Controls, Connectors, and Indicators (150V–600V models) .....	12
Figure 2–4. Single Load with Local Sensing (Default).....	18
Figure 2–5. Single Load with Remote Sensing .....	19
Figure 2–6. Multiple Loads with Local Sensing .....	20
Figure 2–7. Multiple Loads with Remote Sensing .....	20
Figure 3–1. Operating Modes .....	22
Figure 3–2. Local Mode Default Configuration .....	23
Figure 3–3. J11 Sense Connector.....	25
Figure 4–1. J3 Connector.....	28
Figure 4–2. Locating Jumpers, Switch, and Connector.....	29
Figure 4–3. Programming Output Voltage, Current Limit and OVP with REM/LOC Switch. 32	
Figure 4–4. Programming Output Voltage with a 0–5 VDC or 0–10 VDC Source .....	33
Figure 4–5. Programming Output Voltage with a 0–5k Ohm Resistance .....	34
Figure 4–6. Programming Output Current Limit with a 0–5 VDC or 0–10 VDC Source.....	35
Figure 4–7. Programming Output Current Limit with a 0–5k Ohm Resistance .....	36
Figure 4–8. Programming Output Voltage Remotely, Local Control of Current Limit/OVP..	37
Figure 4–9. Programming Output Current Remotely, Local Control of Voltage Limit/OVP..	38
Figure 4–10. Remote Programming of OVP with a 0–5 VDC or 0–10 VDC External Voltage Source .....	40
Figure 4–11. Remote Programming of OVP with a 0–5k ohm Resistance.....	41
Figure 4–12. Using Shutdown with a DC Input (Positive Logic) .....	43
Figure 4–13. Using Shutdown with Contact Closure of a Normally OPEN Relay (S1-6 Up) .....	44
Figure 4–14. Using Shutdown with Contact Closure of a Normally OPEN Relay (S1-6 Down) .....	44
Figure 4–15. Using Shutdown with Contact Closure of a Normally CLOSED Relay (S1-6 Up) .....	44
Figure 4–16. Using Shutdown with Contact Closure of Normally CLOSED Relay (S1-6 Down) .....	45
Figure 4–17. Series Operation of Multiple Supplies .....	47
Figure 4–18. Split Supply Operation of Multiple Supplies (Two Positive Voltages).....	48
Figure 4–19. Split Supply Operation of Multiple Supplies (Positive–Negative Supply).....	48
Figure 4–20. Parallel Operation of Multiple Supplies .....	50
Figure 5–1. Potentiometer Locations .....	53

# SECTION 1

## FEATURES AND SPECIFICATIONS

### 1.1 Description

The DLM-E Series 3000 and 4000 watt power supplies are designed to provide highly stable, continuously variable output voltage and current for a broad range of development, system and burn-in applications. Model numbers for this series are designated by the DLM prefix, followed by the output voltage and current ratings. For example, the model number DLM40-100E indicates that the unit is rated at 0-40 VDC and 0-100 amps while a model DLM8-350E is rated at 0-8 VDC and 0-350 amps. The DLM-E Series employs high frequency switching regulator technology to achieve high power density and small package size.

### 1.2 Operating Modes

The DLM-E Series supply has two basic operating modes: Constant Voltage and Constant Current. In constant voltage mode, the output voltage is regulated at the selected value while the output current varies with the load requirements. In constant current mode, the output current is regulated at the selected value while output the voltage varies with the load requirements.

An **automatic crossover** system enables the unit to switch operating modes in response to varying load requirements. If, for example, the unit is operating in voltage mode and the load current attempts to increase above the setting of the current control, the unit will switch automatically from voltage mode to current mode. If the load current is subsequently reduced below the setting of the current control the unit will return to voltage mode automatically.

### 1.3 Power Supply Features

- 3 kW and 4 kW models with voltage ranges from 0-5 VDC to 0-600 VDC and current ranges from 0-5A to 0-450A.
- 3 kW models operate with either single or three-phase AC input power without jumpers.
- High input AC power factor, 0.95 typical, with three-phase 208, 400, or 480 VAC inputs.

- High input AC power factor, 0.98 typical, with single-phase input.
- Front panel controls for Enable/Standby and Local/Remote modes of operation.
- Simultaneous digital display of both DC voltage and current.
- Front panel preview switch allows voltage, current, and OVP to be preset from local or remote control.
- Local lockout feature with front panel indicator is selectable by rear panel switch.
- No internal jumpers or switches to change programming and monitor ranges.
- Current sharing parallel port and simple cable interface allows several units to be connected in parallel to provide increased power and current.
- Voltage and current controls with ten turn potentiometers permit high resolution setting of the output voltage and current from zero to the rated output.
- Automatic mode crossover into current or voltage mode, with mode indication.
- High frequency switching technology allows high power density, providing increased power output in a small package.
- Remote sensing to compensate for losses in power leads.
- Fast response time for programming or load changes.
- Adjustable Over-Voltage Protection (OVP) with preview
- External DC shutdown (positive or negative logic selectable).
- Remote voltage, current, and OVP programming with selectable programming range.
- External indicator signals for remote monitoring of OVP status, local/remote programming status, thermal shutdown, and output voltage and current.
- Installation Category III, Pollution degree 2.  
For Indoor Use Only.
- CE Approvals to EN61010-1 1993  
CE Mark tested to: EN55011:1991 Group 1 Class A  
EN50082-1:1992  
EN61010-1:1993 + A2:1995
- Optional IEEE-488 interface for complete remote programming and readback capability with M9E option.
- M85 slave option allows programming of up to 31 power supplies from one GPIB address.

## 1.4 Specifications

### 1.4.1 3 kW DLM-E Electrical Specifications<sup>1</sup>

Model	5-350	8-350	16-185	32-95	40-75	60-50	80-37	150-20	300-10	600-5
Output Ratings: Output Voltage Output Current Output Power	0-5V 0-350A 1750W	0-8V 0-350A 2800W	0-16V 0-185A 2960W	0-32V 0-95A 3040W	0-40V 0-75A 3000W	0-60V 0-50A 3000W	0-80V 0-37A 2960W	0-150V 0-20A 3000W	0-300V 0-10A 3000W	0-600V 0-5A 3000W
Line Regulation: <sup>2</sup> Voltage (0.05% of Vmax+2mV) Current (0.1% of Imax)	5 mV 350 mA	6 mV 350 mA	10 mV 185 mA	18 mV 95 mA	22 mV 75 mA	32 mV 50 mA	42 mV 37 mA	77 mV 20 mA	152 mV 10 mA	302 mV 5 mA
Load Regulation: <sup>3</sup> Voltage (0.05% of Vmax+2mV) Current (0.1% of Imax)	5 mV 350 mA	6 mV 350 mA	10 mV 185 mA	18 mV 95 mA	22 mV 75 mA	32mV 50 mA	42 mV 37 mA	77 mV 20 mA	152 mV 10 mA	302 mV 5 mA
Meter Accuracy: Voltage (0.5% Vmax+1count) Current (1.0% Imax+1count)	0.04V 4A	0.05V 4A	0.09V 3A	0.3V 0.8A	0.3V 0.7A	0.4V 0.5A	0.5V 0.4A	0.9V 0.3A	3V 0.09A	4V 0.05A
Preview Accuracy Voltage (0.5% Vmax+1 count) Current (1.0% Imax+1 count)	0.04V 6A	0.05V 5A	0.09V 3A	0.3V 1.1A	0.3V 0.9A	0.4V 0.6A	0.5V 0.5A	0.9V 0.3A	3V 0.11A	4V 0.06A
OVP Adjustment Range (0% to 110% Vmax)	0-5.5V	0-8.8V	0-17.6V	1.6-35V	0-44V	0-66V	0-88V	0-165V	0-330V	0-660V
Output Noise and Ripple (V) RMS p-p (20 Hz-20 MHz)	12 mV 100 mV <sup>4</sup>	12 mV 100 mV <sup>4</sup>	10 mV 100 mV <sup>4</sup>	10 mV 100 mV <sup>4</sup>	10 mV 100 mV <sup>4</sup>	15 mV 100 mV	15 mV 120 mV	30 mV 200 mV	60 mV 300 mV	100 mV 500 mV
Stability: <sup>5, 6</sup> Voltage (0.05% of Vmax) Current (0.05% of Imax)	3 mV 175 mA	4 mV 175 mA	8 mV 93 mA	16 mV 48 mA	20 mV 38 mA	30 mV 25 mA	40 mV 19 mA	75 mV 10 mA	150 mV 5 mA	300 mV 2.5 mA
Temperature Coefficient: <sup>7</sup> Voltage (0.02% of Vmax) Current (0.03% of Imax)	1 mV 105 mA	1.6 mV 105 mA	3.2 mV 55 mA	6 mV 30 mA	8 mV 23 mA	12 mV 15 mA	16 mV 12 mA	30 mV 6 mA	60 mV 3 mA	120 mV 1.5 mA
Maximum Remote Sense Line Drop Compensation per line <sup>8</sup>	2V	2V	2V	5V	5V	5V	5V	5V	5V	5V

- Specifications are warranted over a temperature range of 0-50°C with default local sensing.  
From 50-70°C, derate output 2% per °C.  
From 40-70°C, derate output 2% per °C below 190 VAC with single or three-phase inputs.
- For input voltage variation over the AC input voltage range, with constant rated load.
- For 0-100% load variation, with constant nominal line voltage.
- Typical P-P noise and ripple is 50 mV.
- Maximum drift over 8 hours with constant line, load, and temperature, after 15 minute warm-up (30 minute warm-up for 5V, 8V, and 16V models).
- Current accuracy for 5V, 8V, and 16V models is 1% typical.
- Change in output per °C change in ambient temperature, with constant line and load.
- Line drop subtracts from the maximum available output voltage at full rated power.

1.4.2 4 kW DLM-E Electrical Specifications<sup>9</sup>

Model	5-450	8-450	16-250	32-125	40-100	60-66	80-50	150-26	300-13	600-6.6
Output Ratings: Output Voltage Output Current Output Power	0-5V 0-450A 2250W	0-8V 0-450A 3600W	0-16V 0-250A 4000W	0-32V 0-125A 4000W	0-40V 0-100A 4000W	0-60V 0-66A 3960W	0-80V 0-50A 4000W	0-150V 0-26A 3900W	0-300V 0-13A 3900W	0-600V 0-6.6A 3960W
Line Regulation: <sup>10</sup> Voltage (0.05% of Vmax+2mV) Current (0.1% of Imax)	5 mV 450 mA	6 mV 450 mA	10 mV 250 mA	18 mV 125 mA	22 mV 100 mA	32 mV 66 mA	42 mV 50 mA	77 mV 26 mA	152 mV 13 mA	302 mV 7 mA
Load Regulation: <sup>11</sup> Voltage (0.05% of Vmax+2mV) Current (0.1% of Imax)	5 mV 450 mA	6 mV 450 mA	10 mV 250 mA	18 mV 125 mA	22 mV 100 mA	32mV 66 mA	42 mV 50 mA	77 mV 26 mA	152 mV 13 mA	302 mV 7 mA
Meter Accuracy: Voltage (0.5% Vmax+1count) Current (1.0% Imax+1count)	0.04V 5A	0.05V 5A	0.09V 3A	0.3V 1A	0.3V 0.9A	0.4V 0.6A	0.5V 0.5A	0.9V 0.3A	1.6V 0.11A	3.1V 0.06A
Preview Accuracy Voltage (0.5% Vmax+1 count) Current (1.0% Imax+1 count)	0.04V 6A	0.05V 6A	0.09V 4A	0.3V 1.4A	0.3V 1.1A	0.4V 0.8A	0.5V 0.6A	0.9V 0.4A	3V 0.14A	4V 0.08A
OVP Adjustment Range (0% to 110% Vmax)	0-5.5V	0-8.8V	0-17.6V	0-35V	0-44V	0-66V	0-88V	0-165V	0-330V	0-660V
Output Noise and Ripple (V) RMS p-p (20 Hz-20 MHz)	12 mV 100 mV <sup>12</sup>	12 mV 100 mV <sup>12</sup>	10 mV 100 mV <sup>12</sup>	10 mV 100 mV <sup>12</sup>	10 mV 100 mV <sup>12</sup>	15 mV 100 mV	15 mV 120 mV	30 mV 100 mV	60 mV 150 mV	100 mV 300 mV
Stability: <sup>13, 14</sup> Voltage (0.05% of Vmax) Current (0.05% of Imax)	3 mV 225 mA	4 mV 225 mA	8 mV 125 mA	16 mV 63 mA	20 mV 50 mA	30 mV 33 mA	40 mV 25 mA	75 mV 13 mA	150 mV 6.5 mA	300 mV 3.3 mA
Temperature Coefficient: <sup>15</sup> Voltage (0.02% of Vmax) Current (0.03% of Imax)	1 mV 135 mA	1.6 mV 135 mA	3.2 mV 75 mA	6 mV 38 mA	8 mV 30 mA	12 mV 19.8 mA	16 mV 15 mA	30 mV 7.8 mA	60 mV 3.9 mA	120 mV 2.0 mA
Maximum Remote Sense Line Drop Compensation per line <sup>16</sup>	2V	2V	2V	5V	5V	5V	5V	5V	5V	5V

9. Specifications are warranted over a temperature range of 0-50°C with default local sensing.

From 50-70°C, derate output 2% per °C.

From 40-70°C, derate output 2% per °C below 190 VAC with single or three-phase inputs.

10. For input voltage variation over the AC input voltage range, with constant rated load.

11. For 0-100% load variation, with constant nominal line voltage.

12. Typical P-P noise and ripple is 50 mV.

13. Maximum drift over 8 hours with constant line, load, and temperature, after 15 minute warm-up (30 minute warm-up for 5V, 8V, and 16V models).

14. Current accuracy for 5V, 8V, and 16V models is 1% typical.

15. Change in output per °C change in ambient temperature, with constant line and load.

16. Line drop subtracts from the maximum available output voltage at full rated power.

### 1.4.3 Additional Specifications

#### AC Input:

Output Power	Nominal Input Voltage	Input Option	Input Range (47–63 Hz)	Input Current Maximum <sup>17</sup>	Input Power Factor <sup>18</sup>
3 kW <sup>19</sup>	230 VAC Single-Phase	Std	180–264 VAC L-L	21A RMS	0.98
3 kW <sup>19</sup>	208 VAC Three-Phase	Std	180–264 VAC L-L	12A RMS	0.95
4 kW	208 VAC Three-Phase	Std	180–264 VAC L-L	15A RMS	0.95
4 kW	380/400/415 VAC Three-Phase	M1	345–455 VAC L-L	8.5A RMS	0.95
4 kW	480 VAC Three-Phase	M2	432–528 VAC L-L	6.5A RMS	0.95

17. Maximum input current measured at low AC line and maximum output power.

18. Power factor measured at nominal line, maximum output power.

19. The 3 kW DLM-E is designed to operate without derating to the output power level with either a single-phase or three-phase AC input voltage without any internal jumper changes.

**Efficiency:** 5 and 8 VDC models – 82% typical, 16–600 VDC models – 87% typical

**Altitude:** 2000M (6562 Ft.)

**Operating Temperature Range:** 0 to 50°C

**Storage Temperature Range:** –40 to +85°C

**Humidity Range:** 0 to 80% Non-condensing

**Time Delay from power on until output is stable:** 10 seconds maximum

**Voltage Mode Transient Response Time:** 1 ms recovery to 1% band for 30% step load change from 70% to 100% or 100% to 70%

**Remote Start/Stop and Interlock:** TTL compatible input, Contact Closure, 5–24 VDC.

**Switching Frequency:** Nominal 32 kHz (64 kHz output ripple)

**Float Voltage:** Negative output terminal may be biased to 150 VDC relative to chassis

**Remote Analog Programming (Full Scale Input):** Scales are selectable through rear panel.

Parameter	Resistance	Voltage
Voltage	5 kΩ	5V, 10V
Current	5 kΩ	5V, 10V
OVP	5 kΩ	5V, 10V

**Analog Programming Accuracy:** 1% of rated output for voltage programming, 5% of rated output for resistance programming, 2% of rated output voltage for OVP.

### 1.4.4 Mechanical Specifications

#### Unit Dimensions

Height	Width	Depth	Weight
87.6 mm (3.5 in)	482.6 mm (19 in)	508 mm (20 in)	18.2 kg (40 lbs.)

#### Output Connector (Models DLM5–XXX through DLM80–XX)

**Connector type:** Nickel–plated copper bus bars

**Approximate dimensions:** 1" wide x 0.25" thick

**Distance between positive and negative bus bar main mount in holes:** 2.5"

**Load wiring mounting holes:** Two 0.312" diameter holes for securing high current output cables. Four 0.201" diameter holes for securing lower current cables and sense leads.

**Remote Sensing:** Two pin screw–clamp removable mating connector housing is supplied with each unit for remote sensing. Accommodates sense lead wire 16–22 AWG.

#### Output Connector (Models DLM150–XX through DLM600–XX)

**Connector type:** Four–position terminal block (two positive and two negative connections) #6–32 plated Phillips head SEMS screws accommodate up to #12 AWG.

**Approximate dimensions:** Terminal center spacing of 0.437"

**Safety:** Three-sided plastic cover provided with wire exit cutouts.

**Remote Sensing:** Two pin screw–clamp removable mating connector housing is supplied with each unit for remote sensing. Accommodates sense lead wire 16–22 AWG.

#### Input Connector

**AC Input:** 3–position fuse block with screw clamp connectors.

**Ground:** 10–32 safety ground stud on chassis located below fuse block.

**Note 1:** *Screw clamp connectors accommodate up to AWG #6.*

**Note 2:** *Power cables not supplied.*

**Note 3:** *A clamp–on EMI filter is supplied with each power supply to allow compliance with the Electromagnetic Compatibility Directive requirements of the European Community. See Section 2 for proper installation.*

***SPECIFICATIONS SUBJECT TO CHANGE WITHOUT NOTICE***

# SECTION 2

## INSTALLATION

### 2.1 Introduction

This section provides recommendations and procedures for inspecting, testing, and installing the DLM–E Series power supply.

1. Read and follow safety recommendations (Section 2.2)
2. Perform an initial physical inspection of the supply (Section 2.3)
3. Become familiar with Controls, Indicators and Rear Panel layout (Section 2.4)
4. Install the supply, ensuring adequate ventilation (Section 2.5)
5. Connect the AC input power (Section 2.6)
6. Perform initial function tests for voltage mode operation, current mode operation, and front panel controls (Section 2.7)
7. Connect the load (Section 2.8)

Instructions for Local Programming Mode operation (Constant Voltage and Constant Current) are given in Section 3 Basic Operation. Remote Programming operation, monitoring, and programmable functions are described in Section 4 Advanced Operation.

### 2.2 Safety

Please review the following points for both personal and equipment safety while using the DLM–E Series power supplies.

#### 2.2.1 High Energy/High Voltage Warning

Exercise caution when using and servicing power supplies. High energy levels can be stored at the output voltage terminals on all power supplies in normal operation. In addition, potentially lethal voltages exist in the power circuit and the output connector of power supplies that are

rated at 40V and over. Filter capacitors store potentially dangerous energy for some time after power is removed.

Use extreme caution when biasing the output relative to the chassis due to potentially high voltage levels at the output terminals. The output of the DLM-E Series supplies may be biased up to a maximum voltage relative to the chassis as specified in Section 1 under *Additional Specifications*.

### 2.2.2 AC Source Grounding

Ensure the power supply is connected to an appropriately rated AC outlet with the recommended AC input wiring as set out in *Section 2.6 AC Input Power Connection*. There is a potential shock hazard if the power supply chassis and cover are not connected to a power return via the safety ground on the chassis. The third wire in a single phase AC input connector and the fourth wire in a three phase AC input connector must be connected to an electrical ground at the power outlet. Any disconnection of this ground will cause a potential shock hazard to operating personnel.

This power supply is equipped with an AC line filter to reduce electromagnetic interference and must be connected to a properly grounded receptacle, or a shock hazard will exist.

Operating the supply at line voltages or frequencies in excess of those specified in Section 1 may cause leakage currents in excess of 0.5 mA peak from the AC line to the chassis ground.

### 2.2.3 EMI Provisions

A clamp-on EMI suppression filter core is included with each unit to allow compliance with the Electromagnetic Compatibility Directive requirement of the European Community. This filter is to be installed so that all of the AC input wires and ground wire that connect to the unit at the AC input fuse block and chassis are clamped inside the filter before operating. See Figure 2-1.

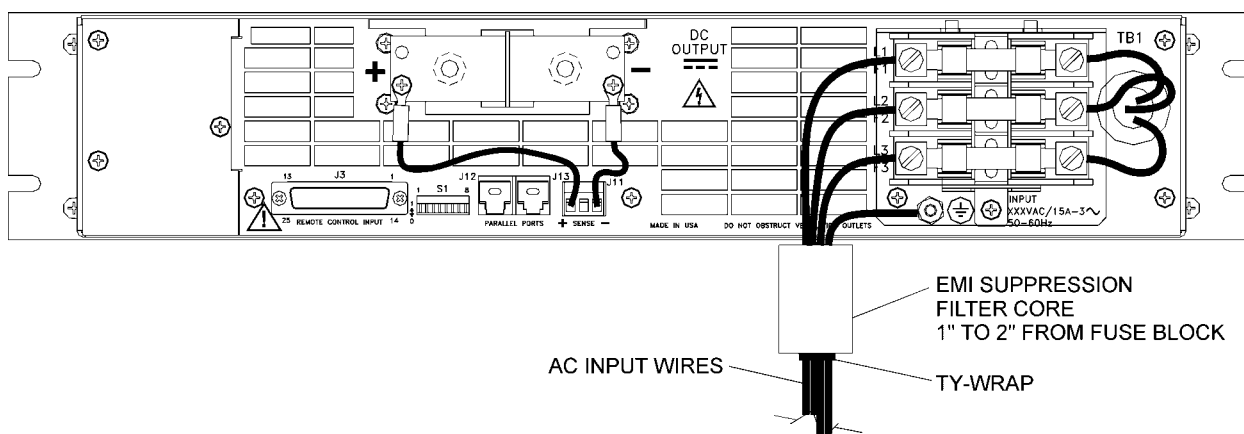

**Figure 2-1. EMI Suppression Filter**

## 2.2.4 Operating and Servicing Precautions

Exceeding a model's maximum rated input voltage may cause permanent damage to the unit. The power supply must not be operated where flammable gases or fumes exist.

Always disconnect power, remove external voltage sources, and allow time for internal circuits to discharge before making internal adjustments or replacing components. When performing internal adjustments or servicing the unit, ensure another person with first aid and resuscitation certification is present. Repairs must be made by experienced technical personnel only.

Be sure to isolate the power supply from the input line with an isolation transformer when using grounded test equipment, such as an oscilloscope, in the power circuit as these are referenced to the AC input line.



### **WARNING!**

**Removal of the front panel filter and cover allows access to moving parts and *potentially hazardous voltages*. Ensure that the power is turned off prior to removal of the filter for maintenance or cleaning.**

## 2.2.5 Parts and Modifications

Do not use substitute parts or make any unauthorized modifications to the power supply to ensure that its safety features are not degraded. Contact Sorensen customer service engineers for service and repair help.

## 2.3 Initial Inspection

Upon first receiving your DLM-E Series power supply, perform a quick physical check, paying particular attention to front panel controls and indicators as well as rear panel connectors and terminals. The front and rear panel diagrams are located in *Section 2.4*.

### 2.3.1 Physical Check

After unpacking, perform an initial inspection to ensure the unit and parts shipped with it have not been damaged in transit. The package should contain the power supply, a manual, a remote sense connector, a 25-pin sub-D mating connector for J3, and an EMI filter core.

1. Inspect for dents to the cover and chassis; for scratches and cracks on the front and rear panels; and for any broken controls, connectors, or displays.
2. Turn front panel controls from stop to stop. Rotation should be smooth.
3. Test the action of the POWER switch. Switching action should be positive.
4. If internal damage is suspected, remove the cover and check for printed circuit board and/or component damage. Reinstall cover.

If damage has occurred, save all packing materials and notify the carrier immediately. Refer to the terms of the warranty. Direct any repair problems to the manufacturer.

**Note:** Section 2.7 Initial Functional Tests *contains electrical and operational tests you can perform to ensure the unit is in proper working order after shipment. Run these tests after applying AC input power but before connecting the load to the power supply.*

## 2.4 Controls, Connectors, and Indicators

Refer to Figure 2–2 or Figure 2-3 (depending on the model) and the descriptions below.

### 2.4.1 Front Panel User Controls and Indicators

1. **CURRENT** knob: 10 turn adjustment sets the output current.
2. **VOLTAGE** knob: 10 turn adjustment sets the output voltage.
3. **OVP SET** potentiometer: 20 turn trim pot recessed behind front panel sets the over voltage trip limit.
4. **POWER** switch: Two–position switch enables or disables the supply.
5. **ENABLE/STANDBY** switch: Two–position switch allows the unit to be placed in an active (enabled) or inactive (standby) mode. The front panel displays are still active in the STANDBY mode.
6. **LOCAL/REMOTE** switch: Two–position switch selects if the front panel VOLTAGE, CURRENT and OVP controls (local) or the analog programming inputs from the rear panel J3 connector (remote) will determine the output settings for the supply.
7. **PREVIEW** switches: Two momentary push button switches. While in the STANDBY mode, the V&I button will display the output voltage and current settings prior to power being applied to the load. The OVP button will display the over voltage shutdown set point. Local or remote signal preview settings are selectable with the LOCAL/REMOTE mode switch position.
8. **VOLTAGE DISPLAY**: 3½ digit green LED display normally indicates DC output voltage of supply. Indicates preset output voltage setting when the V&I PREVIEW button is pushed and indicates the OVP setting when the OVP PREVIEW button is pushed.
9. **VOLTAGE MODE** indicator: Green LED lights when in the constant–voltage mode of operation. When in the constant voltage mode, the output voltage will regulate to the set value and the current value will vary with the load.
10. **CURRENT MODE** indicator: Green LED lights when in the constant–current mode of operation. When in the constant current mode, the output current will regulate to the set value and the output voltage will vary with the load.
11. **CURRENT DISPLAY**: 3½ digit green LED display normally indicates DC output current of supply. Push the V&I PREVIEW button to display preset output current setting.
12. **ON** (Output On) indicator: Yellow LED lights when power switch is on and AC is applied.
13. **S/D** (Shutdown) indicator: Red LED lights when the unit has been shutdown remotely.
14. **REM** (Remote) indicator: Green LED lights when unit is in remote programming mode.
15. **OVP** (Over Voltage Protection) indicator: Red LED lights when an over voltage shutdown has occurred.

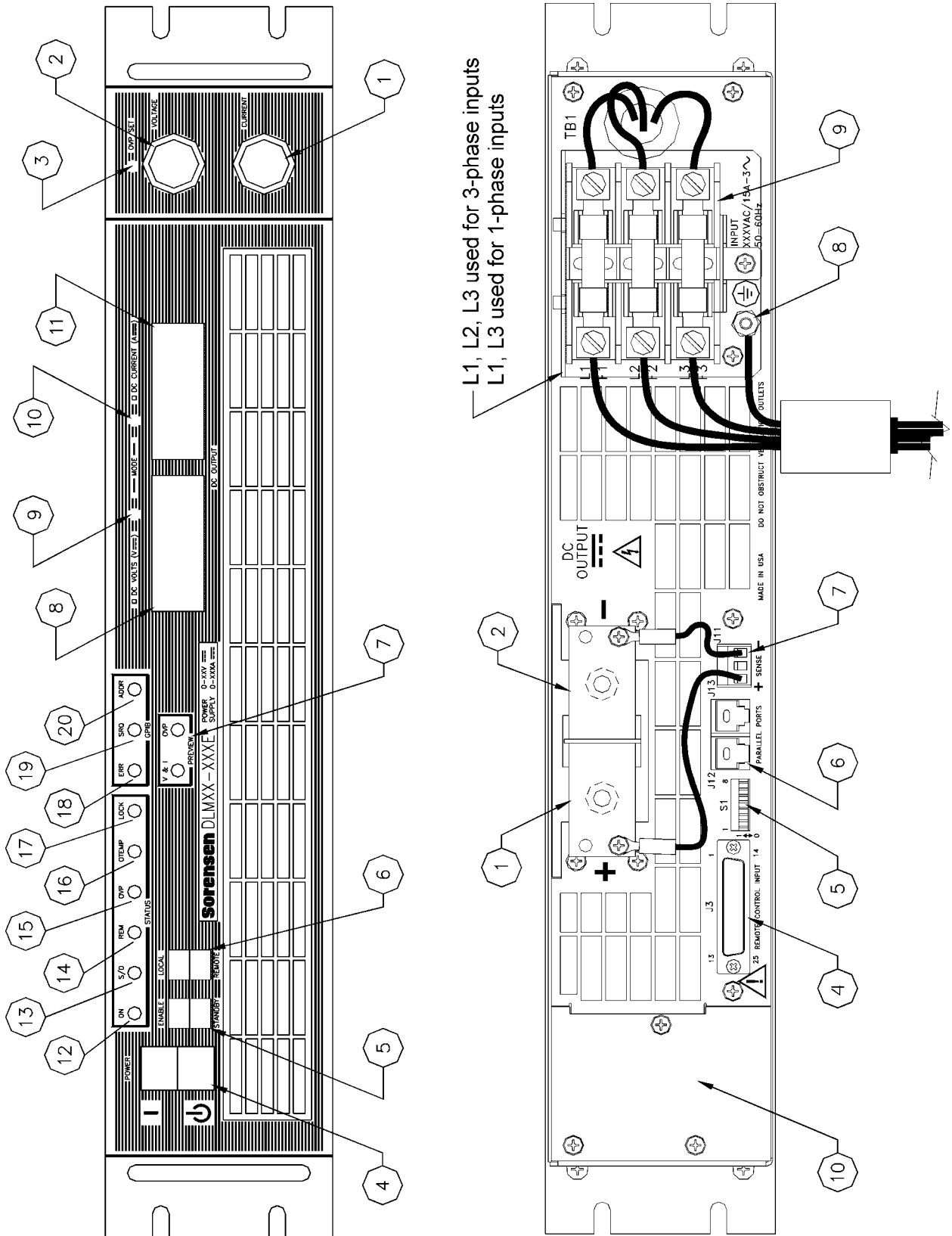

Figure 2-2. DLM-E Controls, Connectors, and Indicators (5V-80V models)

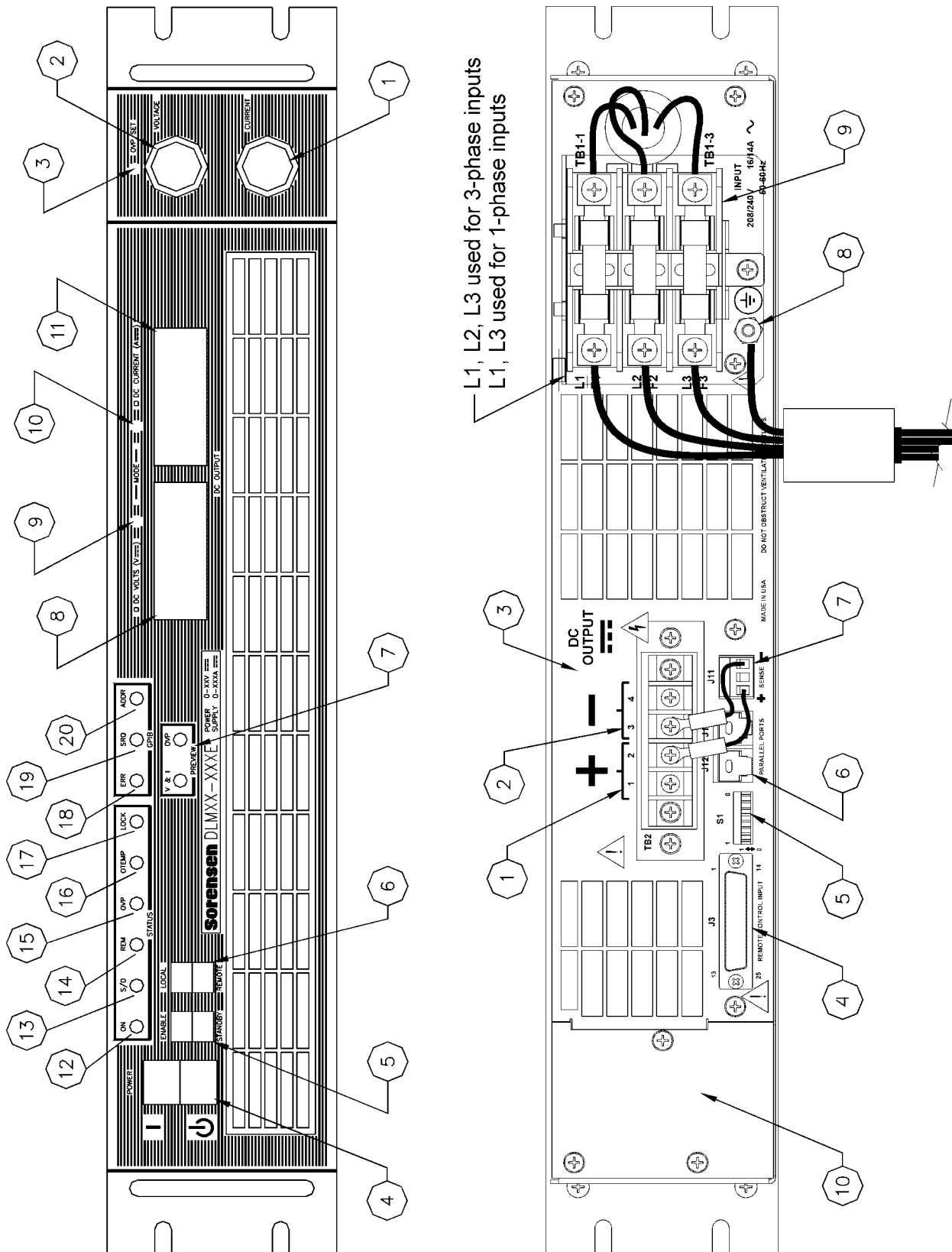

Figure 2-3. DLM-E Controls, Connectors, and Indicators (150V-600V models)

16. **OTEMP** (Over Temperature) indicator: Red LED lights when an over temperature shutdown has occurred.
17. **LOCK** (Lockout) indicator: Green LED lights when in Lockout mode. Activated by connection through rear panel DIP switch. Can only be activated when the front panel LOCAL/REMOTE switch is in the **REMOTE** position. Once the Lock function has been activated, it disables LOCAL control for all output control functions except the AC power switch, which remains under front panel control.

The following indicators will be illuminated only when the optional GPIB controller is installed:

18. **ERR** (Error) indicator: Red LED lights to signal a GPIB programming error has occurred.
19. **SRQ** (Service Request) indicator: Green LED lights to signal GPIB service request by the supply.
20. **ADDR** (Address) indicator: Green LED lights when the unit is addressed by a remote controller.

#### 2.4.2 Rear Panel

Refer to Figure 2–2 or Figure 2-3 (depending on the model) and the descriptions below.

1. Positive Output (+). Bus bar for 5V through 80V models.  
TB2–1 and 2 for 150V through 600V models.
2. Negative Output (–). Bus bar for 5V through 80V models.  
TB2–3 and 4 for 150V through 600V models.
3. Output connector location for 150V through 600V models.
4. Programming and Monitor Connector, **J3**. I/O connector for input programming and analog output monitoring signals as well as status indication and remote shutdown signals. See Table 4–1 for individual pin descriptions.
5. DIP Switch **S1**. Eight–position right angle slide DIP switch. Controls full scale settings for Voltage, Current and OVP programming range, Voltage and Current Output Monitor range, Remote On–Off logic selection, Master/Slave operation and Lockout operating mode selections. See Table 4–2 for Rear Panel DIP switch functions and settings.
6. Parallel Port connectors, **J12** and **J13**. Used in conjunction with S1 setting to control multiple units in parallel mode with current sharing. See Table 4–2 for Rear Panel DIP switch functions and settings and Table 4–3 for parallel port connector function and pinout.
7. Sense connector, **J11**. Remote sense lead connection for local and remote load voltage sensing on all models. Connections shown are for local sensing on all models.
8. AC Input chassis safety ground stud.
9. AC Input Connector/fuse block with removable safety cover.
10. Area for optional GPIB assembly.

## 2.5 Location, Mounting, and Ventilation

The DLM–E system supply is designed for use in rack mounted applications. Ensure that sufficient space is allowed for cooling air to reach the ventilation inlets on the front of the unit, and for fan exhaust air to exit from the rear of the unit.

### 2.5.1 Unit Dimensions

Dimension	Height	Width	Depth	Weight
Standard	3.5 in	19 in	20 in	40 lbs
Metric	87.6 mm	482.6 mm	508 mm	18.2 kg

### 2.5.2 Rack Mounting

The supply is designed to fit in a standard 19" equipment rack. Use adjustable support angles such as Hammond RASA22WH2, or a support bar such as Hammond RASB19WH2. Bolt holes in the chassis sides are provided for rack mount slides such as the ZERO #C300S18 slides.

Be sure to provide adequate support for the rear of the unit while not obstructing the exhaust outlets at the rear of the unit.



**CAUTION!**  
Rack mounting bolts must not extend more than 3/16" into the side of the power supply.

### 2.5.3 Ventilation

The DLM–E system supply is fan–cooled, so it requires unobstructed space on the front ventilation inlets and space at the rear for the ventilation exhaust. The following temperature ranges apply for the best results when operating or storing the unit.

Operating Ambient Temperature <sup>1</sup>	Storage Temperature Range
0 to 50° C with no derating.	–40 to +85° C

- From 50 to 70° C, derate 2% per °C.  
From 40 to 70°C, derate 2% per °C below 190 VAC with single or three–phase inputs.

## 2.6 AC Input Power Connection

Before you can use the DLM-E system supply, you must determine your AC input power requirements and connect an appropriate cable or line cord to the input connector. The power supply is shipped with an input connector cover which you need to remove to make the input power connections.



### WARNING!

**A device to disconnect the DLM-E supply from the energy supply source is required. This switch or circuit breaker must be close to the DLM-E supply, within easy reach of the operator, and clearly labeled as the disconnection device for the DLM-E supply.**

### 2.6.1 AC Input Power Requirements

The specifications for input voltage, current, and frequency are listed below.

Output Power	Nominal Input Voltage	Input Option	Input Range (47–63 Hz)	Input Current Maximum <sup>2</sup>	AC Input Terminals
3 kW <sup>3</sup>	230 VAC Single-Phase	Std	180–264 VAC L-L	20A RMS	L1–L3 <sup>4</sup> (F1–F3)
3 kW <sup>3</sup>	208 VAC Three-Phase	Std	180–264 VAC L-L	12A RMS	L1–L2–L3 (F1–F2–F3)
4 kW	208 VAC Three-Phase	Std	180–264 VAC L-L	15A RMS	L1–L2–L3 (F1–F2–F3)
4 kW	380/400/415 VAC Three-Phase	M1	345–455 VAC L-L	8.5A RMS	L1–L2–L3 (F1–F2–F3)
4 kW	480 VAC Three-Phase	M2	432–528 VAC L-L	6.5A RMS	L1–L2–L3 (F1–F2–F3)

2. Maximum input current measured at low AC line and maximum output power.
3. The 3 kW DLM-E is designed to operate without derating to the output power level with either a single-phase or three-phase AC input voltage without any internal jumper changes.
4. Single-phase AC inputs use L1 and L3 only. Improper connections will result in no output.

### 2.6.2 Input Line Impedance

The maximum input line impedance for operation at full rated output is 0.1 ohm. Higher source impedance can be tolerated by raising the input line voltage or by reducing the power.

## 2.7 Initial Functional Tests

Before connecting the unit to an AC outlet, make sure that the POWER switch is in the Off position, (down) and that the voltage and current control knobs are turned fully counter-clockwise. The two smaller switches directly to the right of the POWER switch should be depressed up to put the unit in the ENABLE and LOCAL position. Check that the J3 mating connector on the rear of the unit has no jumpers installed on it and that the rear panel DIP switch, S1, settings are all in the UP (1) position. (This is the default configuration as shipped from the factory). Connect the unit to the proper AC power source and turn the POWER switch on. After a 1–2 second power-on delay, the front panel meters should light up with both displays reading zero. The S/D (shutdown) indicator will blink momentarily and then the ON and VOLT MODE indicators should be illuminated.

To check **voltage mode operation**, proceed as follows:

- Connect a DVM, rated better than 0.5% accuracy, to the rear output terminals, observing correct polarity.
- Rotate the CURRENT control  $\frac{1}{2}$  turn clockwise. Slowly rotate the VOLTAGE control clockwise and observe both the internal and external meters. The control range should be from zero to the maximum rated output. Compare the test meter reading with the front panel voltmeter reading. Check that the green VOLTAGE MODE indicator is ON.
- Set the POWER switch to OFF. Note that the internal fans will continue to run for about 10 seconds.

To check **current mode operation**, proceed as follows:

- Rotate the VOLTAGE and CURRENT controls fully counterclockwise.
- Rotate the VOLTAGE control  $\frac{1}{2}$  turn clockwise.
- Connect a high current DC ammeter or current shunt across the rear output terminals, observing correct polarity. Select cables of sufficient current carrying capacity and an ammeter range compatible with the unit's rated current output. The ammeter/shunt should have an accuracy of better than 0.5%.
- Set the POWER switch to ON.
- Rotate the CURRENT control slowly clockwise. The control range should be from zero to the maximum rated output. Compare the test meter reading with the reading on the front panel ammeter. Check that the green CURRENT MODE indicator is ON.
- Set the POWER switch to OFF. Note that the internal fans will continue to run for about 10 seconds.

## 2.8 Load Connection

Reliable performance of the DLM–E power supply can be obtained if certain basic precautions are taken when connecting it in a system. To obtain a stable, low noise output, careful attention should be paid to factors such as conductor ratings, system grounding techniques and the way in which the load and remote sensing connections are made.

### 2.8.1 Load Conductor Ratings

As a minimum, load wiring must have a current capacity greater than the output current rating of the power supply. This ensures that the wiring will not be damaged even if the load is shorted. The table below shows the maximum current rating, based on 450 amps per square centimeter, for various gauges of wire rated for 105 degrees C operation.

Operation at the maximum current rating results in approximately a 30-degree temperature rise for a wire operating in free air. Where load wiring must operate in areas with elevated ambient temperatures or bundled with other wiring, larger gauges or higher temperature-rated wiring should be used.

To overcome impedance and coupling effects, which can degrade the power supply performance, the use of leads of the largest gauge and shortest length possible is recommended.

AWG	Maximum Current
16	7
14	11
12	18
10	23
8	39
6	67
4	106
2	170

AWG	Maximum Current
1	209
1/0	270
2/0	330
3/0	350
4/0	408
250 MCM	425
300 MCM	480

### 2.8.2 Noise and Impedance Effects

To minimize noise pickup or radiation from load circuits, load wires and remote sense wires should be twisted-pair with minimum lead length. Shielding of the sense leads may be necessary in high noise environments. Even if noise is not a concern, the load and remote sense wires should be twisted-pairs to reduce coupling between them, which could impact the stability of the power supply. If connectors are utilized for the power and sense leads, be careful not to introduce coupling between the leads. Ensure that the connector terminals for the sense leads are in adjacent locations, and minimize the physical loop area of the untwisted portions. Ideally, the sense leads should be separated from the power leads and should have their own connector.

Twisting the load wires provides an additional benefit in reducing the parasitic inductance of the cable. This improves the dynamic response characteristics at the load by maintaining a low source impedance at high frequencies. Also, with long load wires, the resultant inductance and resistance could produce high frequency voltage spikes at the load due to current variations in the load itself. The impedance introduced between the output of the power supply and the load could make the ripple/noise at the load worse than the specifications of the power supply (which are valid when measured at the rear panel bus bars). Additional filtering with bypass capacitors at the load terminals may be required to bypass the high frequency load currents.

### 2.8.3 Making the Connections

Load connections to the power supply are made at the positive and negative output terminals (or bus bars) at the rear of the power supply. See Figure 2–2. The power supply provides three load wiring mounting holes on each bus bar terminal, as specified in the following table. The small holes can be used for local sense lines.

Load Wiring Mounting Holes	Diameter	Hardware Size
One (1) per terminal	0.312"	1/4" (5/16" for 8V and 16V models)
One (1) per terminal	#6–32 Screw	0.32" OD (for 150V–600V models)
Two (2) per terminal	0.201" on 0.5" centers	#10 or smaller



**CAUTION!**  
**When making connections to the bus bars, provide support when tightening hardware to prevent bending bus bars. Ensure that the mounting hardware at each terminal and wiring assembly is placed to avoid touching the other terminal and shorting the power supply output. Heavy connecting cables must have some form of strain relief to avoid loosening the connections or bending the bus bars.**



**CAUTION!**  
**If unit is not installed in a rack, care should be taken to protect personnel from contact with output bus bars.**

### 2.8.4 Connecting Single Loads

Figure 2–4 and Figure 2–5 show recommended load and sensing connections for a single load. Local sense lines shown are default J11 connections. Refer to Section 3.3.1 Connecting Remote Sense Lines for more information about the sense line shield.

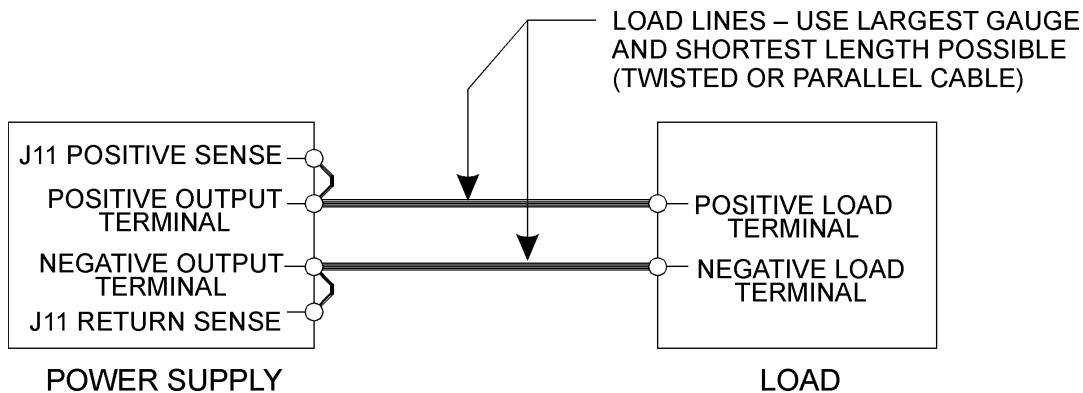

**Figure 2–4. Single Load with Local Sensing (Default)**  
 (Local sense lines shown are default J11 to busbar connections)

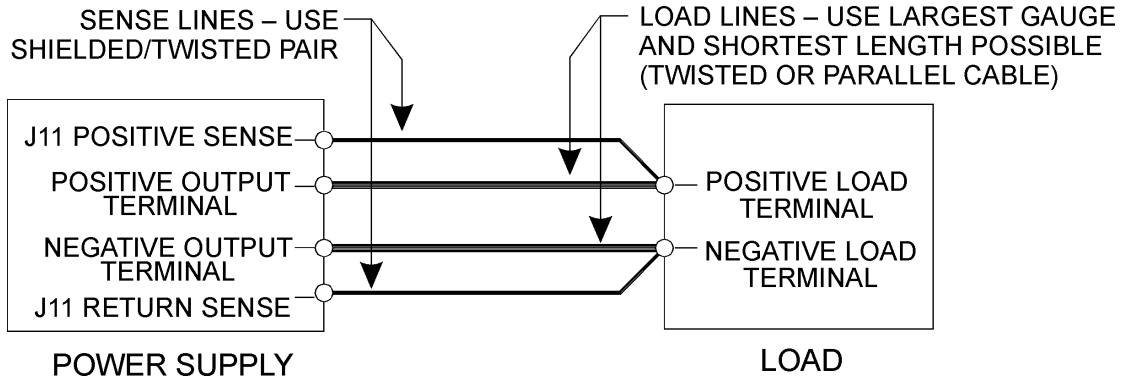

**Figure 2–5. Single Load with Remote Sensing**  
(Local sense lines shown are default J11 to busbar connections)

### 2.8.5 Connecting Multiple Loads

Proper connection of distributed loads is an important aspect of power supply applications. Two common methods of connection are the parallel power distribution method and the radial distribution method.

Proper connection of distributed loads is an important aspect of power supply application. A common mistake is to connect leads from the power supply to one load, from that load to the next load, and so on for each load in the system. In this **parallel power distribution** method, the voltage at each load depends on the current drawn by the other loads and DC ground loops are developed. Except for low current applications, this method should not be used.

The preferred way to distribute power is by the **radial distribution** method in which power is connected to each load individually from a single pair of terminals designated as the positive and negative distribution terminals. The pair of terminals may be the power supply output terminals, the terminals of one of the loads or a distinct set of terminals specially established for distribution. Connecting the sense leads to these terminals will compensate for losses and minimize the effect of one load upon another.

Figure 2–6 and Figure 2–7 show recommended load and sensing connections for multiple loads. Local sense lines shown are default J11 connections. Refer to Section 3.3.1 Connecting Remote Sense Lines for more information about grounding the sense line shield.

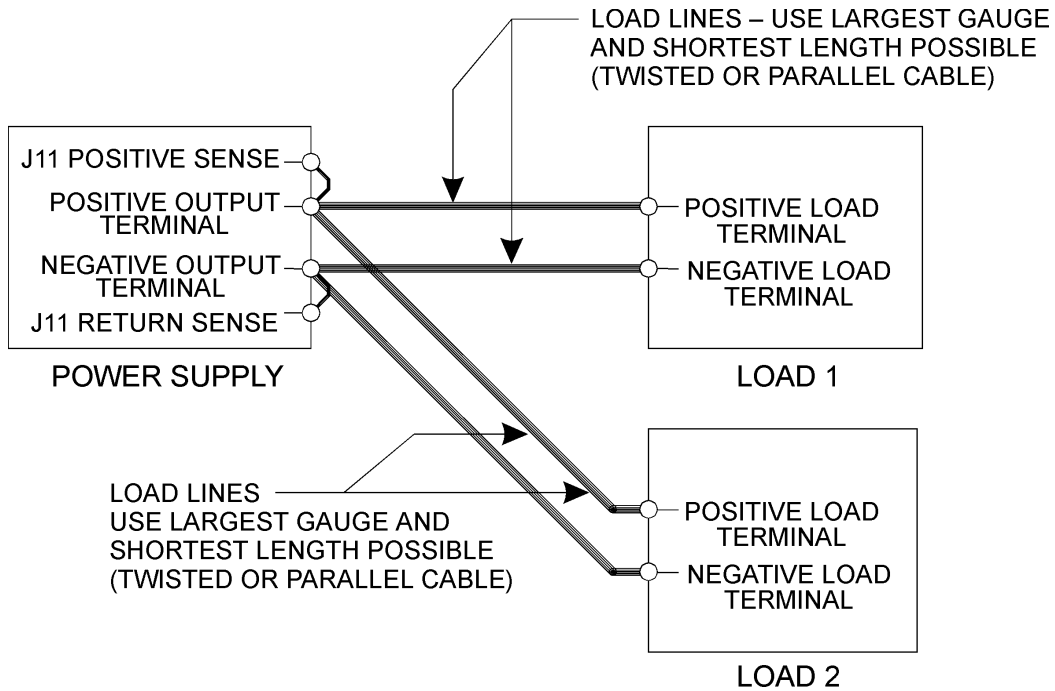

**Figure 2-6. Multiple Loads with Local Sensing**  
 (Local sense lines shown are default J11 to busbar connections)

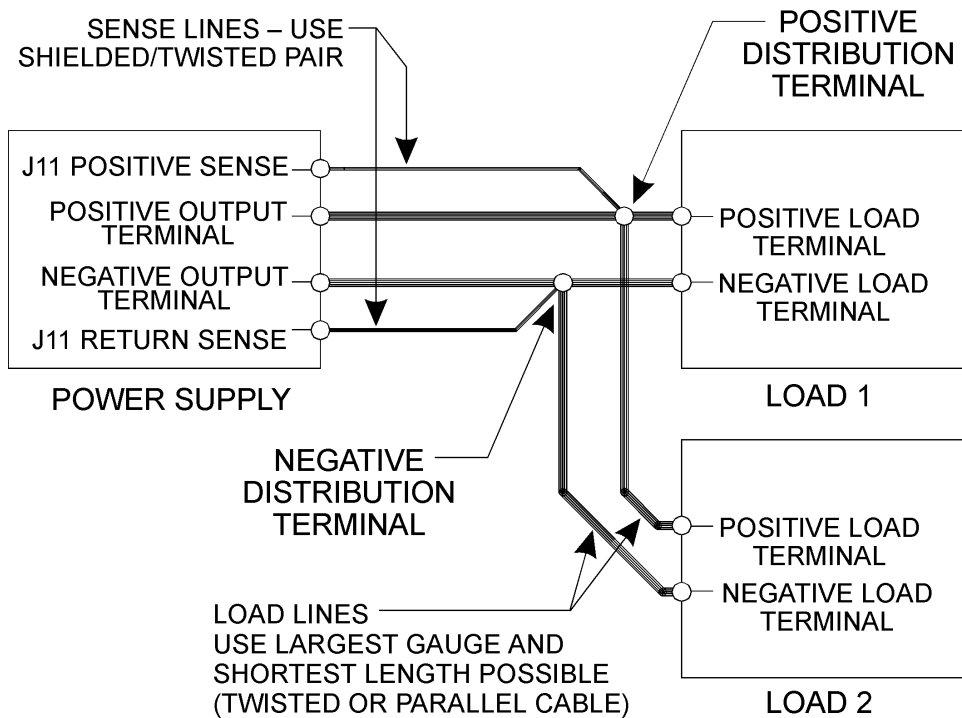

**Figure 2-7. Multiple Loads with Remote Sensing**  
 (Local sense lines shown are default J11 to busbar connections)

## SECTION 3

# BASIC OPERATION

### 3.1 Introduction

Once the power supply installation is complete and both the AC input power and the load have been connected (see Section 2 Installation), the DLM–E Series power supply is in its default configuration and is ready to operate in local programming mode.

This section covers Constant Voltage and Constant Current Mode operation as controlled by local programming (Section 3.2). Remote sensing for voltage mode operation is described and illustrated in Section 3.3.

Remote Programming operation, monitoring, and programmable functions are described in Section 4 Advanced Operation.

### 3.2 Standard Operation

The DLM–E Series power supply has two basic **operating modes**: Constant Voltage Mode and Constant Current Mode, and two **control modes**: Local Programming Mode (default setting) and Remote Programming Mode. Both operating modes are available regardless of which control mode is used.

This section deals with power supply operation using the Local Programming in both Constant Voltage and Constant Current Modes. Remote Programming Mode as well as monitoring and programmable functions information is found in Section 4 Advanced Operation. Also see Section 3.3 for remote sense operations.

#### 3.2.1 Operating Modes and Automatic Crossover

Whether controlled by local or remote programming, the power supply has two basic operating modes: Constant Voltage Mode and Constant Current Mode. The mode in which the power supply operates at any given time depends on the combination of:

- the output voltage setting  $V_{SET}$  and
- the output current limit setting  $I_{SET}$  and
- the resistance of the attached load  $R_L$ .

Figure 3–1 provides a graphical representation of the relationships between these variables.

### Constant Voltage Mode Operation

The power supply will operate in constant voltage mode whenever the load current  $I_L$  **is less than** the current limit setting  $I_{SET}$ , or:  $I_L < I_{SET}$  (Note:  $I_L = V_{SET} / R_L$ )

In constant voltage mode, the power supply maintains the output voltage at the selected value ( $V_{SET}$ ) while the load current  $I_L$  varies with the load requirements.

### Constant Current Mode Operation

The power supply will operate in constant current mode whenever the load resistance is low enough that the load current  $I_L$  **is greater than** the current limit setting  $I_{SET}$ , or:  $I_L > I_{SET}$

In constant current mode, the power supply maintains the output current at the selected value ( $I_{SET}$ ) while the load voltage varies with the load requirements.

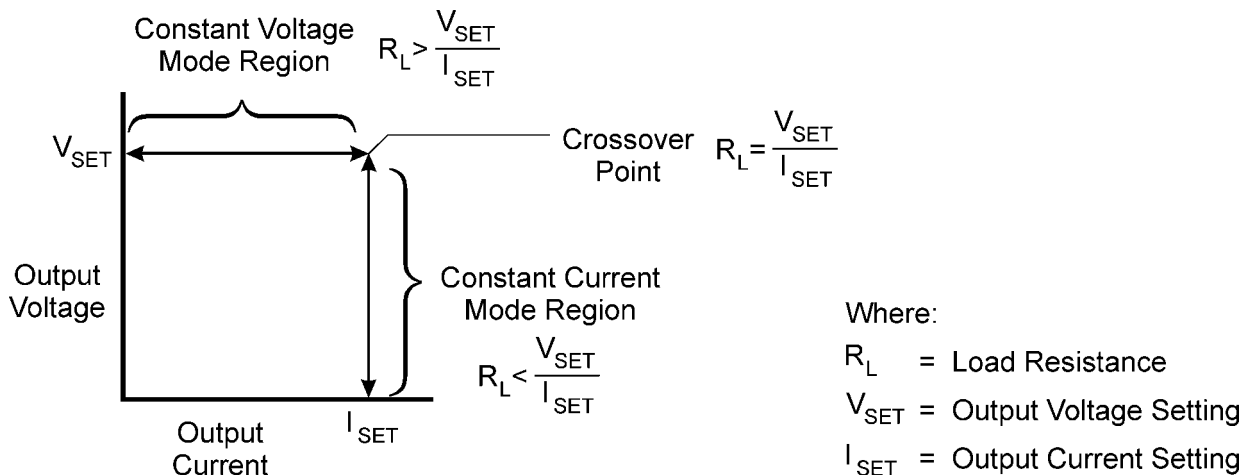

**Figure 3–1. Operating Modes**

### Automatic Mode Crossover

This feature allows the power supply to automatically switch operating modes in response to changing load requirements. If, for instance, the power supply was operating in Constant Voltage Mode ( $I_L < I_{SET}$ ), and the load changed so that the load current ( $I_L$ ) became **greater than** the current limit setting ( $I_{SET}$ ), the power supply would automatically switch into Constant Current Mode. If the additional load was subsequently removed so that the load current was again **less than** the current limit setting, the supply would automatically return to Constant Voltage Mode.

### 3.2.2 Local Programming Mode Operation

Units are shipped from the factory configured for local programming mode operation. In local programming mode:

- Output voltage and current limit settings are adjusted with the front panel controls.
- The sense point of the supply is at the output terminals.
- The front panel OVP potentiometer determines the OVP set point.  
See Section 4.4 Using Over Voltage Protection (OVP) for the adjustment procedure.

#### **Local Mode Default Configuration**

Figure 3–2 shows the default factory settings for switch S1. These controls are used to select among the various options for programming, sensing, and monitoring. See *Section 4.2 Configuring for Remote Programming, Sensing, and Monitoring*.

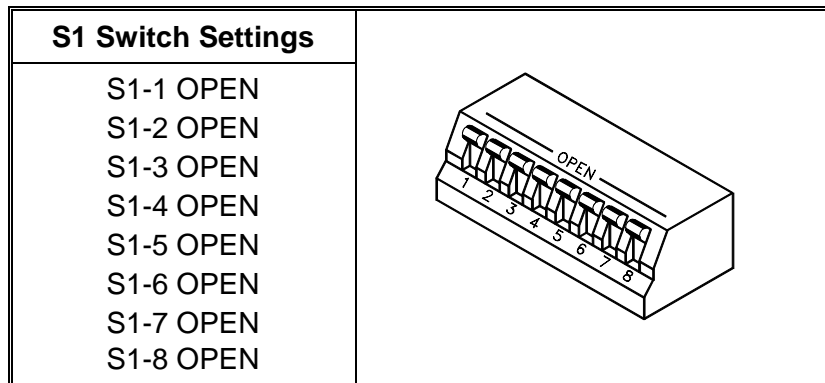

**Figure 3–2. Local Mode Default Configuration**

#### **Setting Output Voltage and Current Limit**

After installing the power supply and connecting the load as described in Section 2 Installation, set the required output voltage and current limit according to the following front panel procedure:

1. Turn both the voltage and current controls fully counter-clockwise.
2. Press the **ENABLE/STANDBY** switch to the **STANDBY** position to disable the power supply output.
3. Press the **LOCAL/REMOTE** switch to the **LOCAL** position for front panel operation.
4. Turn the **POWER** switch **ON**.
5. Press and hold the **V&I PREVIEW** button to display the voltage and current control settings on the voltmeter and ammeter displays.

6. Adjust the voltage control to the required voltage (this will be the maximum compliance voltage for applications using current mode operation).
7. Adjust the current control to the required current limit setting.
8. Release the **V&I PREVIEW** button.
9. Press the **ENABLE/STANDBY** switch to the **ENABLE** position to apply power to the load.
10. The output Voltmeter and Ammeter will now display the actual values being supplied to the load.

### 3.3 Using Remote Sensing

Remote sensing is used during voltage mode operation to shift the power supply's regulation point from its output terminals (default sense point) to the load or distribution terminals by using a separate pair of wires to monitor the load voltage. Remote sensing allows the power supply to compensate for voltage losses in the load lines which would otherwise degrade the regulation of the supply. The sense line connection points are located on the rear panel J11 connector. *Section 4.2 Configuring for Remote Programming, Sensing, and Monitoring* has more information about making J3 connector changes.

**CAUTION!**

**Do not use remote sensing with multiple supplies connected in series or in parallel.**

#### 3.3.1 Connecting Remote Sense Lines

The DLM-E Series units are shipped with the rear panel J11 Sense connector jumpered for local sensing of the output voltage. With local sensing, the output voltage is regulated at the output. This method does not compensate for voltage losses in the load lines, so it is recommended only for low current applications or applications for which load regulation is not essential.

To connect remote sense lines, refer to Figure 3-3 and to the following procedure:

1. Ensure the power supply is turned OFF. Allow several minutes to elapse to dissipate stored energy before altering J11 connector pin connections.
2. Remove the local sense jumpers connecting J11 pin 1 (positive sense) and pin 3 (negative sense or return sense) to the local bus bar or connector.
3. Connect the positive sense lead from the load to J11 pin 1 and the negative lead to J11 pin 3. Use shielded-twisted pair wiring of 22 AWG or larger for sense lines.
4. Ground the sense line shield, at one point only, to the power supply's return output connection at the load, or, to the power supply's return output at its output terminal, or to the power supply's chassis.

5. The optimal point for the shield ground must be determined by experiment, but the most common connection point is at the power supply's return output connection at the load.
6. Turn the power supply ON.

**Notes:**

1. If the power supply is operated with remote sense lines connected and with either of the positive or negative load lines **not** connected, the power supply shutdown circuit will be activated, causing the output voltage and current to fall to zero.
2. If the power supply is operated **without** remote sense lines **or** local sense jumpers in place, the supply will continue to work, but supply regulation will be degraded and/or erratic.

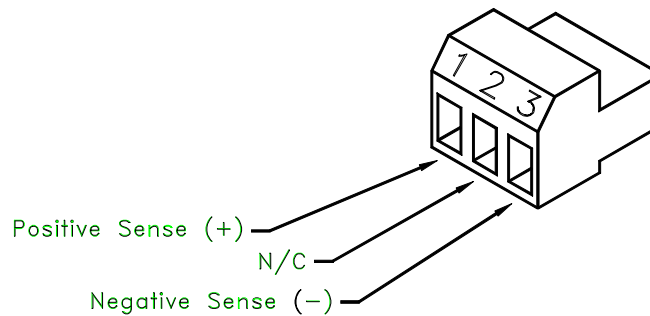

**Figure 3–3. J11 Sense Connector**

**Rear Panel J11 Sense Connector Terminals and Functions**

Terminal	Name	Function
J11-1	Positive Sense (+SNS)	Remote positive sense connection. Default connection to (+) bus bar or output connector.
J11-2	N/C	No connection.
J11-3	Return Sense (–SNS)	Remote negative sense connection. Default connection to (–) bus bar or output connector.

This page intentionally left blank.

## SECTION 4

# ADVANCED OPERATION

### 4.1 Introduction

The DLM-E Series power supplies offer the following standard features:

- Remote Programming of Output Voltage and Current Limit with 0–5V, 0–10V or 0–5k ohms (Section 4.3)
- Overvoltage Protection (OVP) with front panel control or 0–5, 0–10V or 0–5k ohms programming (Section 4.4)
- Programmable Shutdown with DC, or TTL compatible signals and contact closure (Section 4.5)
- Remote Monitoring of Status Indicators for thermal shutdown, OVP status, remote/local programming mode, and voltage/current mode operation (Section 4.6)
- Calibrated Readback Signals for output voltage and output current with selectable 0–5V or 0–10V scales (Section 4.6)
- Multiple Supply Configurations such as series, parallel, and split supply (Section 4.7)
- Remote Voltage Sensing (Section 3.3)
- Output Voltage Biasing (Section 4.7)

Accessing these features may require that you use one or more of the following procedures:

- Using the front panel REMOTE/LOCAL programming switch.
- Reconfiguring the rear panel J3 connector.
- Making connections to the J3 connector.
- Resetting rear panel DIP switch S1.

*Section 4.2 Configuring for Remote Programming, Sensing, and Monitoring* provides a reference to the function and location of these controls, and procedures for making any required changes.

## 4.2 Configuring for Remote Programming, Sensing, and Monitoring

This section lists front panel switch, J11 connector, and rear panel DIP switch functions for the DLM-E Series supplies. Subsequently, it provides a location diagram (Section 4.2.2), in addition to procedures for resetting the jumpers and switches (Section 4.2.3), and for reconfiguring or making connections to the J3 connector (Section 4.2.4).

You will find remote programming procedures and diagrams covered in more detail in Section 4.3, remote sensing in Section 3.3, and remote monitoring of readback signals and status indicators in Section 4.6.

### 4.2.1 Programming, Monitoring, and Control Functions

#### **Front Panel REMOTE/LOCAL Switch**

You can use the REMOTE/LOCAL Programming switch for remote programming. When set to REMOTE programming, control of OUTPUT VOLTAGE, CURRENT LIMIT and OVP is passed to external voltage or current sources which are connected to the J3 connector. Resetting the switch to LOCAL position returns the supply to local (front panel) control. See Section 4.3 for more information about using this switch.

#### **External J3 Connector** (see Figure 4-1)

The factory default configuration for the J3 connector is with no jumpers or other connections. The external J3 connector provides user access to the following functions:

- Remote programming of output voltage or current limit, and for OVP
- Remote monitoring of the following readback signals and status indicators

Readback Signals	Status Indicators
Voltage Monitor Current Monitor	Overtemperature shutdown OVP status Remote/Local programming mode Volt/Curr operating mode

- Remote programming of the shutdown function using DC or TTL compatible signals



**WARNING!**

Use extreme caution when biasing the output relative to the chassis due to potentially high voltage levels at the output and J3 terminals.

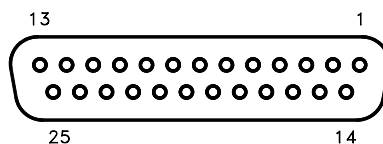

**Figure 4-1. J3 Connector**

Pin No.	Function	Pin No.	Function
1	Remote Output Enable 1 = Enable, 0 = Disable	14	Remote Shutdown Input (+). Positive or negative true logic selection with S1
2	Remote Shutdown Return (-)	15	+5 VDC Aux. Output
3	Remote OVP Programming Input	16	1 mA current source for OVP Programming
4	Remote Programming Indicator 1 = Remote, 0 = Local	17	OVP Status Indicator 1 = OVP Shutdown, 0 = Normal
5	Operating Mode Indicator 1 = Volt mode, 0 = Current mode	18	Overtemp Shutdown Indicator 1 = OTP Shutdown, 0 = Normal
6	Status Indicator Return (-)	19	DC Voltage Monitor Output
7	Current Monitor Output	20	Remote/Local Voltage Control Select
8	N/C	21	1 mA current source for Voltage Programming
9	Voltage Programming Input	22	1 mA current source for Current Programming
10	Current Programming Input	23	Remote/Local Current Control Select
11	N/C	24	N/C
12	Programming/Monitor Return (-)	25	N/C
13	N/C		

**Table 4–1. J3 Connector – Program, Control, and Monitor Description**  
(D-subminiature 25-Pin Female)

#### 4.2.2 Rear Panel DIP Switch

Switch S1 is located on the main printed circuit board and is able to be changed through the rear panel of the power supply. The J3 connector is located on the unit's rear panel. See Section 4.2.3 Resetting Rear Panel DIP Switch Settings and Section 4.2.4 Making J3 Connections.

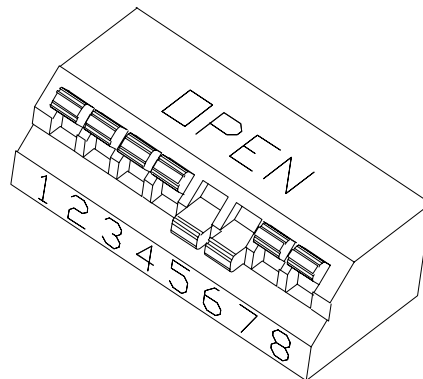

**Figure 4–2. Locating Jumpers, Switch, and Connector**

Switch Position	Function	Open Position (Up) *	Closed Position (Down)
S1-1	Voltage Programming Input Range	0–5 VDC	0–10 VDC
S1-2	Current Programming Input Range	0–5 VDC	0–10 VDC
S1-3	OVP Programming Input Range	0–5 VDC	0–10 VDC
S1-4	Voltage Monitor Output Range	0–5 VDC	0–10 VDC
S1-5	Current Monitor Output Range	0–5 VDC	0–10 VDC
S1-6	Remote Shutdown Activation	Active High Signal	Active Low Signal
S1-7	Master/Slave Parallel Output Enable	Single or Master	Slave
S1-8	Front Panel Lockout	Normal	Lockout Mode

\* Factory default position

**Table 4–2. Rear Panel S1 DIP Switch Functions and Settings**

#### 4.2.3 Resetting Rear Panel DIP Switch Settings

Some applications require the default factory settings of the rear panel 8–position DIP switch, S1. If the switch requires resetting, read Section 2.2, and follow the procedures in this section.

**Always turn off the front panel power switch before moving any DIP switch settings.**

#### 4.2.4 Making J3 Connections

The default factory configuration of the J3 connector has no jumpers. Other applications will require placing pin–to–pin connections or making connections to external devices such as voltage sources, or resistances. Read Section 2.2 Safety, and follow the procedures in this section whenever the rear panel connector, J3, is to be reconfigured. **Always turn off the front panel power switch before soldering to the J3 connector, and only solder with the mating connector removed from the supply.**

##### **Making the Connection**

To make pin–to–pin connections:

1. Unsolder any unnecessary pin–to–pin jumpers as required by the application.
2. Solder new connections using any appropriate single bus wire such as AWG 20 to 24.

To connect external source leads, resistance leads, or monitoring lines:

3. Unsolder any unnecessary jumpers as required by the application.
4. Solder leads to the specified pin using the recommended wiring and/or grounding point for the application. Pin, wiring, and grounding specifications for particular applications can be found in *Section 4. Advanced Operation* except for remote sensing specifications which are in *Section 3.3 Using Remote Sensing*.

**NOTE**

**When the front panel LOCAL/REMOTE Switch is moved to REMOTE operation, voltage, current, and OVP programming functions must be remotely programmed. For clarity, only the connections for the function being described are shown in the following figures.**

### 4.3 Remote Programming of Output Voltage and Current Limit

Remote programming allows control of the power supply's output voltage and/or current limit to shift from local operation at the front panel voltage and current controls to external analog input sources. As a programming source is varied, the power supply's output varies proportionally over its output range.

The analog programming signals are connected to the rear panel J3 connector. To provide the lowest noise performance, **shielded-twisted pair wiring is recommended for making connections from external circuits to the J3 connector**. Use the shortest leads possible. Ground the shield to pin 12 on the J3 connector or to the chassis via one of the J3 connector screws.



**CAUTION!**

**The remote programming input is internally referenced to the supply's negative output. Do not connect remote programming input lines (J3 pins 9 & 10) to the supply's positive output.**

#### Remote Programming Options

The following table summarizes access options for programming output voltage and current limit with the input scales supported for the DLM-E Series supply. Refer to Section 4.3.1 for a procedure and a connection diagram for programming output voltage and current limit using the REMOTE/LOCAL switch. Subsequent sections provide short procedures and diagram the J3 connector configurations and connections required for remote programming of output voltage and/or current limit without using the REMOTE/LOCAL switch.

<b>Remote Programming Options</b>	<b>Control of ...</b>	<b>Programming Scales *</b>
Programming with the REMOTE/LOCAL Switch	Output Voltage Current Limit Over Voltage Setting	0-5V, 0-10V, 0-5K
Programming without the REMOTE/LOCAL Switch (Jumper J3 Connector)	Output Voltage and/or Current Limit	0-5V, 0-10V, 0-5K Local control

\* These scales may be used in any combination

### 4.3.1 Programming Output Voltage and Current Limit with the REMOTE/LOCAL Switch

The front panel REMOTE/LOCAL Programming switch will allow you to switch back and forth between remote and local operation when programming output voltage and current limit with external voltage and/or current sources.

For programming output voltage and current limit using the REMOTE/LOCAL switch:

1. Connect a programming source between pins 9 (voltage programming input/positive) and 12 (return).
2. Connect a programming source between pins 10 (current limit programming input/positive) and 12 (return).
3. Connect a programming source between pins 3 (OVP programming input/positive) and 12 (return).
4. Connect a TTL high signal to Pin 1 (remote output enable). An external source must be referenced to Pin 6 (common). Pin 15 (+5V) may be used as a source.
5. Set the front panel REMOTE/LOCAL switch to REM.

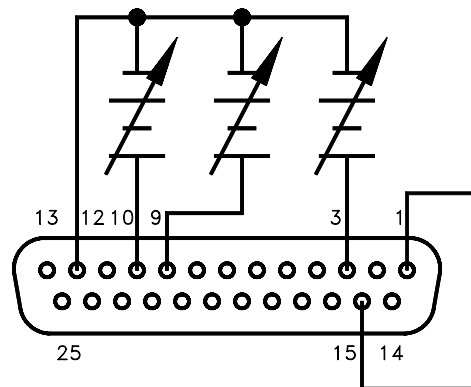
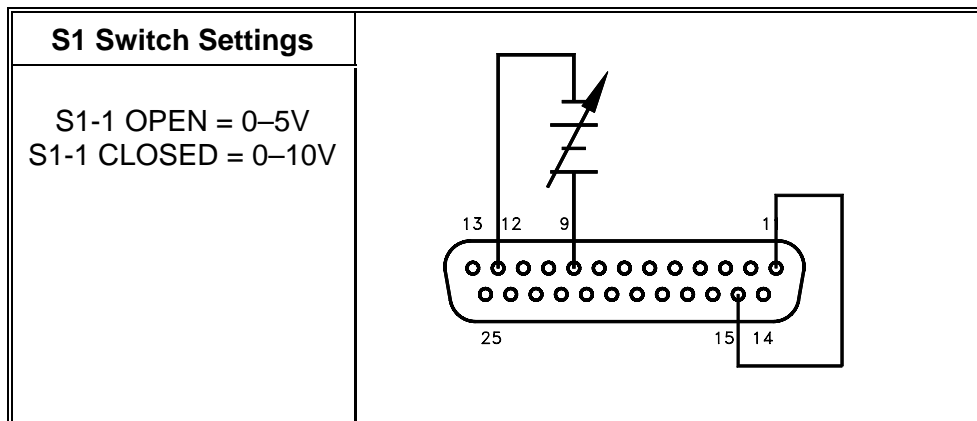

**Figure 4–3. Programming Output Voltage, Current Limit and OVP with REM/LOC Switch**

### 4.3.2 Programming Output Voltage

#### **Programming Output Voltage with a 0–5 VDC or 0–10 VDC Source**

1. Set S1-1, the rear panel DIP Switch, UP, in the open position for 0–5 VDC programming range.
2. Set S1-1, the rear panel DIP Switch, DOWN, in the closed position for 0–10 VDC programming range.
3. Connect the external programming source between pins 9 (voltage programming input/positive) and 12 (return). Varying the programming voltage from 0 to maximum will cause the output to vary from 0 to 100% of the model rating. Adjust the programming signal to zero.
4. Turn the power supply ON.
5. Set the front panel LOCAL/REMOTE switch to the REMOTE position and adjust the external programming source voltage. By pressing the V&I PREVIEW button and observing the front panel voltmeter reading, the external control can be adjusted to the desired setting.



**Figure 4–4. Programming Output Voltage with a 0–5 VDC or 0–10 VDC Source**

### **Programming Output Voltage with Resistance**

1. Set S1-1, the rear panel DIP Switch, UP, in the open position for 0–5k ohm programming range.
2. Connect pins 9 (voltage programming input/positive) and 21 (1mA current source for voltage control) to the counter-clockwise end of the potentiometer and connect the tap and clockwise end of the potentiometer to pin 12 (return). Adjusting the resistance from 0 to maximum will vary the output voltage from 0 to 100% of the model rating. Adjust the programming signal to zero.
3. Turn the power supply ON.
4. Set the front panel LOCAL/REMOTE switch to the REMOTE position and adjust the external programming resistance. By pressing the V&I PREVIEW button and observing the front panel voltmeter reading, the external control can be adjusted to the desired setting.

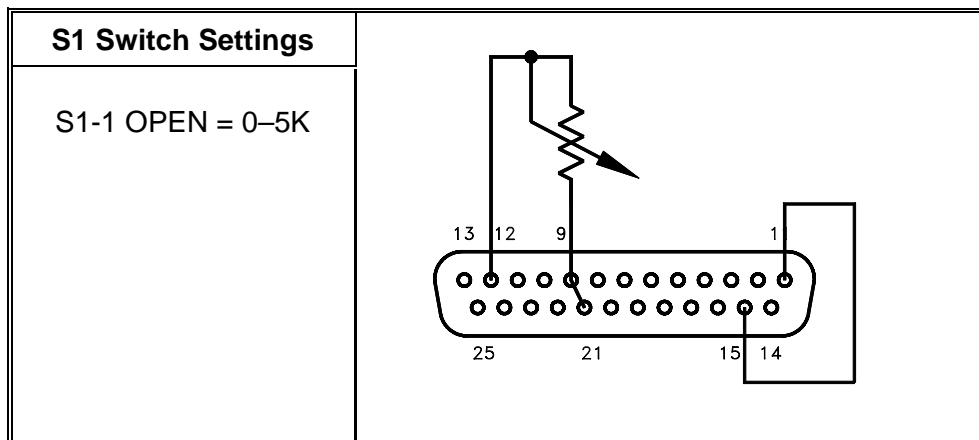
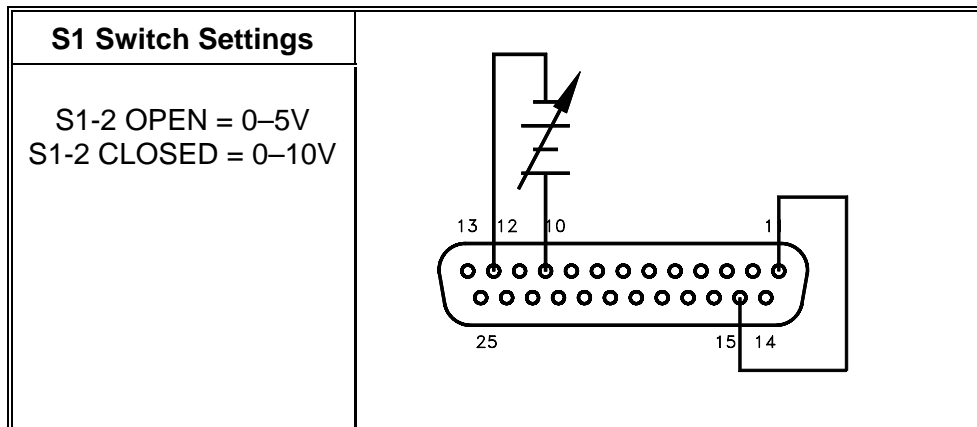

**Figure 4–5. Programming Output Voltage with a 0–5k Ohm Resistance**

### 4.3.3 Programming Output Current Limit

#### **Programming Output Current Limit with a 0–5 VDC or 0–10 VDC Source**

1. Set S1-2, the rear panel DIP Switch, UP, in the open position for 0–5 VDC programming range.
2. Set S1-2, the rear panel DIP Switch, Down, in the closed position for 0–10 VDC programming range.
3. Connect the external programming source between pins 10 (current programming input/positive) and 12 (return). Varying the programming voltage from 0 to maximum will cause the output to vary from 0 to 100% of the model rating. Adjust the programming signal to zero.
4. Turn the power supply ON.
5. Set the front panel LOCAL/REMOTE switch to the REMOTE position and adjust the external programming voltage source. By pressing the V&I PREVIEW button and observing the front panel ammeter reading, the external control can be adjusted to the desired setting.



**Figure 4–6. Programming Output Current Limit with a 0–5 VDC or 0–10 VDC Source**

### **Programming Output Current Limit with a 0–5k Ohm Resistance**

1. Set S1-2, the rear panel DIP Switch, UP, in the open position for 0–5k ohm programming range.
2. Connect pins 10 (current programming input/positive) and 22 (1mA current source for current control) to the counter-clockwise end of the potentiometer and connect the tap and clockwise end of the potentiometer to pin 12 (return). Adjusting the resistance from zero to maximum will vary the output voltage from 0 to 100% of the model rating. Adjust the programming signal to zero.
3. Turn the power supply ON.
4. Set the front panel LOCAL/REMOTE switch to the REMOTE position and adjust the external programming resistance. By pressing the V&I PREVIEW button and observing the front panel ammeter reading, the external control can be adjusted to the desired setting.

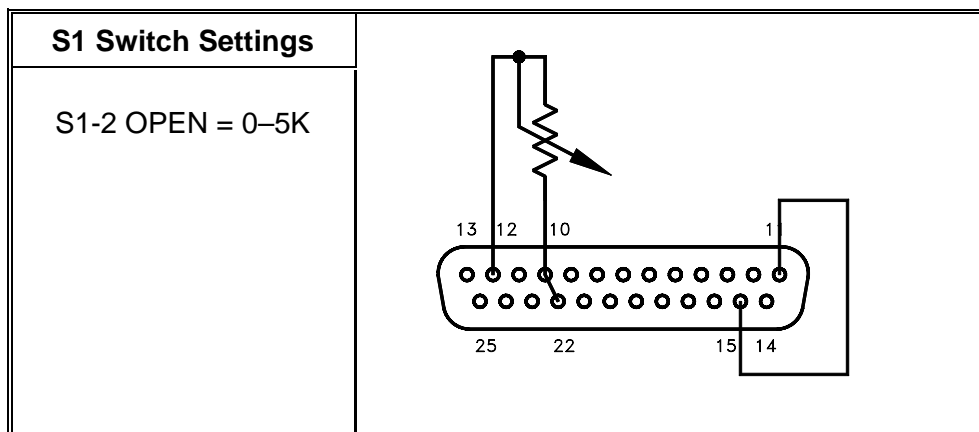

**Figure 4–7. Programming Output Current Limit with a 0–5k Ohm Resistance**

#### 4.3.4 Remote Programming Only the Output Voltage or Current Limit

The front panel REMOTE/LOCAL switch allows you to switch back and forth between remote and local programming signals for all three programming inputs of Voltage, Current, and OVP. When operation is desired for programming only the output voltage and/or current limit without the other, or to leave the OVP control on the front panel, follow the procedures below:

##### **Remote Programming of the Output Voltage Only**

For remote programming of output voltage only:

1. Turn off power to the supply.
2. Connect a programming source to remote programming connector **J3** between pins **9** (voltage programming input/positive) and **12** (return).
3. Connect a jumper between remote programming connector pins **J3-20** and **J3-21** for external control of output voltage.
4. Adjust the external programming signal to zero.
5. Switch the **ENABLE/STANDBY** switch to **STANDBY**.
6. Turn the power supply **ON**.
7. Set the front panel **LOCAL/REMOTE** switch to the **LOCAL** position and adjust the external programming signal. By pressing the **V&I PREVIEW** button and observing the front panel voltmeter reading, the external control can be adjusted to the desired setting.
8. Adjust the current and **OVP** controls to the desired settings with the front panel controls
9. Switch the **ENABLE/STANDBY** switch to **ENABLE**.
10. The output voltage is now remotely programmed with local control of the current limit and **OVP** settings.

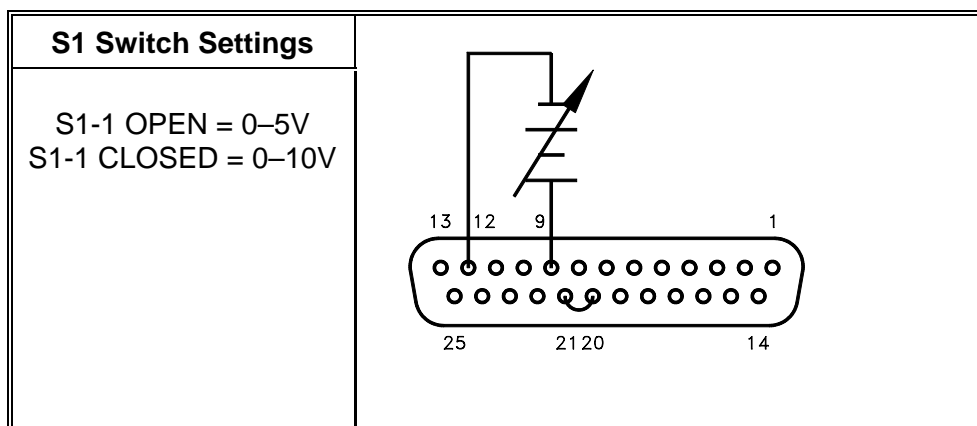

**Figure 4–8. Programming Output Voltage Remotely, Local Control of Current Limit/OVP**

**Remote Programming of the Current Limit Only****CAUTION!**

**Always remove J3 mating connector from supply before soldering.**

For remote programming of current limit only:

1. Turn off power to the supply.
2. Connect a programming source between pins 10 (current limit programming input/positive) and 12 (return).
3. Connect a jumper between remote programming connector pins J3-22 and J3-23 for external control of the current limit.
4. Adjust the external programming signal to zero.
5. Switch the ENABLE/STANDBY switch to STANDBY.
6. Turn the power supply ON.
7. Set the front panel LOCAL/REMOTE switch to the LOCAL position and adjust the external programming signal. By pressing the V&I PREVIEW button and observing the front panel ammeter reading, the external control can be adjusted to the desired setting.
8. Adjust the voltage and OVP controls to the desired settings with the front panel controls.
9. Switch the ENABLE/STANDBY switch to ENABLE.
10. The current limit setting is now remotely programmed with local control of the output voltage and OVP settings.

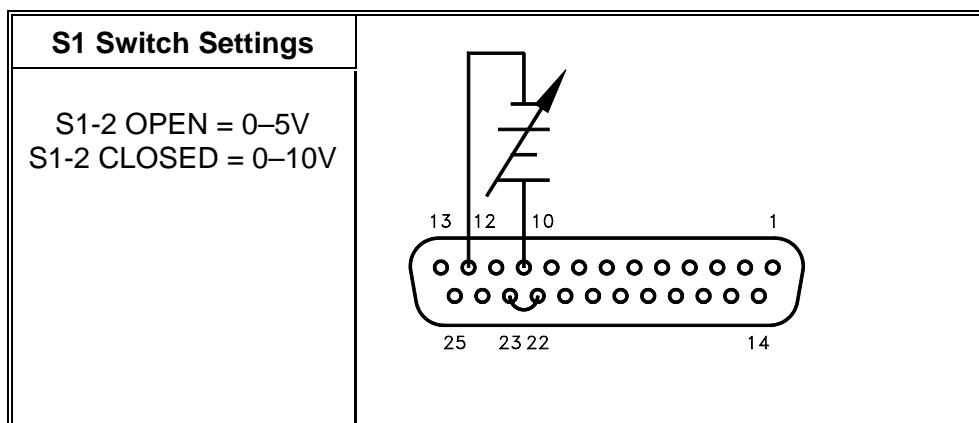

**Figure 4–9. Programming Output Current Remotely, Local Control of Voltage Limit/OVP**

## 4.4 Using Over Voltage Protection (OVP)

The OVP circuit allows for protection of the load in the event of a remote programming error, an incorrect voltage control adjustment, or a power supply failure. The protection circuit monitors the output voltage and will reduce the output current and voltage to zero whenever a preset voltage limit is exceeded. The preset voltage limit, also called the set point or trip level, can be set either in local programming mode from the front panel or by remote programming through the J3 connector on the rear panel.

The red OVP LED on the front panel will light up when the OVP circuit has been activated.

### 4.4.1 Front Panel OVP Operation

In local programming mode, the OVP set point can be checked at any time by pressing the OVP PREVIEW switch: The OVP set point is the value displayed on the digital voltmeter.

To set the trip level from the front panel:

1. Adjust the power supply output to zero volts.
2. Press the OVP PREVIEW switch to observe the OVP set point on the voltmeter display.
3. Turn the OVP SET potentiometer until the desired set point is reached. Release the OVP CHECK switch.
4. Increase the power supply output voltage to check that the power supply shuts off the output at the selected set point.

### 4.4.2 Resetting the OVP Circuit

To reset the OVP circuit after it has been activated:

1. Reduce the power supply's output voltage setting to below the OVP set point.
2. Press the ENABLE/STANDBY switch to the STANDBY position.
3. Return the ENABLE/STANDBY switch to the ENABLE position and resume normal operation.

or

1. Reduce the power supply's output voltage setting to below the OVP set point.
2. Turn the power supply OFF using the POWER switch, then turn it back ON again.

### 4.4.3 Programming OVP with an External Voltage Source



**CAUTION!**

Always remove J3 mating connector from supply before soldering.

#### Programming OVP with a 0–5 VDC or 0–10 VDC Source

1. Set S1-3, the rear panel DIP Switch, UP, in the open position for 0–5 VDC programming range.
2. Set S1-3, the rear panel DIP Switch, DOWN, in the closed position for 0–10 VDC programming range.
3. Connect the external programming source between pins 3 (OVP programming input/positive) and 12 (return). Varying the programming voltage from zero to maximum will cause the OVP setting to vary from approximately 0 to 110% of the model rating.
4. Turn the power supply ON and adjust the external voltage programming to zero.
5. Set the front panel LOCAL/REMOTE switch to the REMOTE position and adjust the external OVP programming source voltage. By pressing the OVP PREVIEW button and looking at the front panel voltmeter setting, the external control can be adjusted to the desired value.
6. Slowly increase the external output voltage programming signal until the red OVP LED lights and the power supply shuts down.

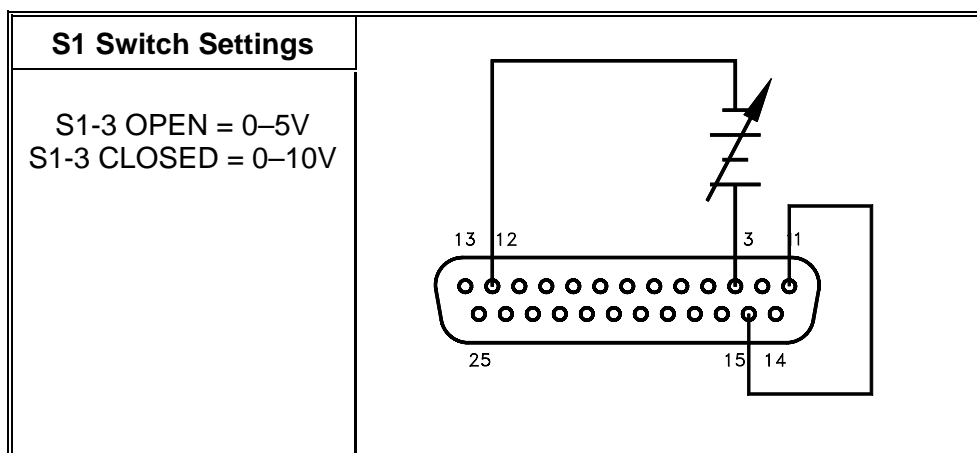

**Figure 4–10. Remote Programming of OVP with a 0–5 VDC or 0–10 VDC External Voltage Source**

### **Programming OVP with a 0–5k Ohm Resistance**

1. Set S1-3, the rear panel DIP Switch, UP, in the open position for 0–5 k ohm programming range.
2. Connect the external programming source between pins 3 (OVP programming input/positive) and 12 (return). Varying the programming voltage from zero to maximum will cause the OVP setting to vary from approximately 0 to 110% of the model rating.
3. Connect pins 3 (OVP programming input/positive) and 16 (1mA current source for OVP control) of J3 to the counter-clockwise end of the potentiometer and connect the tap and clockwise end of the potentiometer to pin 12 (return). Adjusting the resistance from zero to maximum will vary the output voltage from approximately 0 to 110% of the model rating.
4. Turn the power supply ON and adjust the external voltage programming input to zero.
5. Set the front panel LOCAL/REMOTE switch to the REMOTE position and adjust the external OVP programming source voltage. By pressing the OVP PREVIEW button and looking at the front panel voltmeter setting, the external control can be adjusted to the desired value.
6. Slowly increase the external output voltage programming signal until the red OVP LED lights and the power supply shuts down.

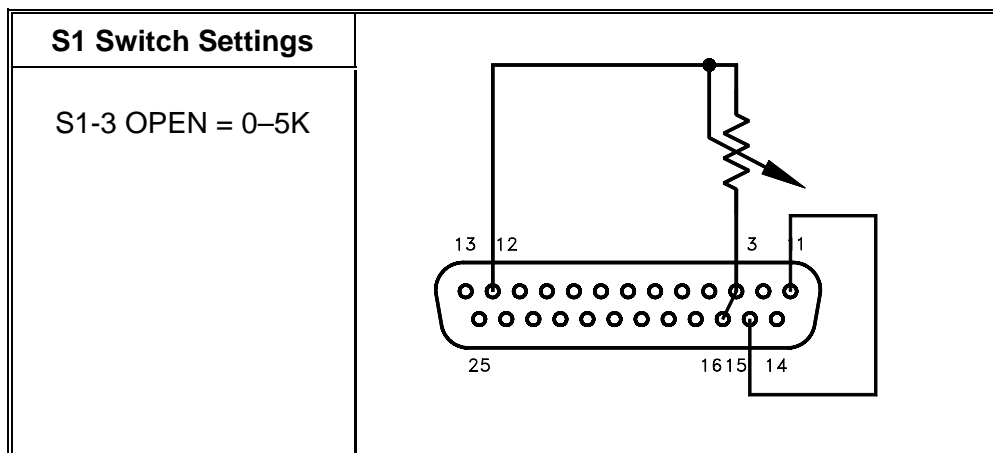

**Figure 4–11. Remote Programming of OVP with a 0–5k ohm Resistance**

## 4.5 Using the Shutdown Function

The Shutdown function is used to disable or enable the supply's output voltage and current. It can be used to allow adjustments to be made to either the load or the power supply without shutting off the entire supply. This function may be activated from the front panel at any time by using the STANDBY switch. It can also be activated via remote programming, using positive or negative logic, with a TTL compatible input or higher DC signal.

### 4.5.1 STANDBY Switch

The STANDBY switch is a two-position rocker switch located on the power supply's front panel. See the front panel diagram in Section 2. When in the STANDBY position, the shutdown circuit is activated, and the output voltage and current are programmed to zero. Pushing the switch to the ENABLE position allows normal power supply operation to resume.

### 4.5.2 Programming the Shutdown Function

The Shutdown circuit uses a 5–24 VDC input to disable or enable the power supply output. Connections for the input signals are made on connector J3. Rear panel DIP switch S1-6, determines whether positive or negative logic for the signal is used. The input lines for the Shutdown circuit are optically isolated and can therefore be used by input sources with a voltage differential of up to +/- 150 VDC.

#### **External Wiring**

Use 20 to 24 AWG wiring when making connections to the J3 connector. Keep wiring as short as possible.

#### **TTL Shutdown**

To activate the Shutdown function using a DC input:

1. Turn off the power supply.
2. Connect the signal source to J3 pin 14 (Remote Shutdown Input/positive) and J3 pin 2 (Return for Shutdown Input) on the J3 connector on the rear panel. See Figure 4–12.
3. Set internal switch SW1-6 to select the desired circuit logic as defined in the following table.

Switch S1-6 Setting	Signal Level	Output Condition
UP/Open = Positive Logic	High	OFF
	Low	ON
DOWN/Closed = Negative Logic	High	ON
	Low	OFF

The red S/D (Shutdown) LED on the front panel lights up when the Shutdown circuit is activated.

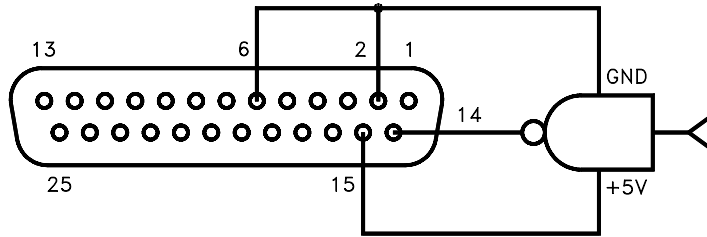

**Figure 4–12. Using Shutdown with a DC Input (Positive Logic)**

4.5.3 Shutdown Application – Contact Closure

An external relay, whether normally open or normally closed, may be used to activate the Shutdown circuit. Either positive or negative logic may be used.

To activate the Shutdown function using an external relay:

1. Turn off the power supply.
2. Connect one side of the external relay to pin 15 (+5 VDC Auxiliary Output) on connector J3. Connect the other side of the relay to J3-pin 14 (Remote Shutdown Input). Also connect pin 2 (Shutdown Return) to pin 6 (Status Indicator Return). See Figure 4–13 through Figure 4–16.
3. Set rear panel DIP switch S1 to select the desired circuit logic as defined in the following table.

Relay	Switch S1-6 Setting	Relay Coil State	Output
Normally Open Relay	UP–Open (Positive Logic)	Energized	OFF
		De-energized	ON
	DOWN–Closed (Negative Logic)	Energized	ON
		De-energized	OFF
Normally Closed Relay	UP–Open (Positive Logic)	Energized	ON
		De-energized	OFF
	DOWN–Closed (Negative Logic)	Energized	OFF
		De-energized	ON

The red S/D (Shutdown) LED on the front panel lights up when the Shutdown circuit is activated.

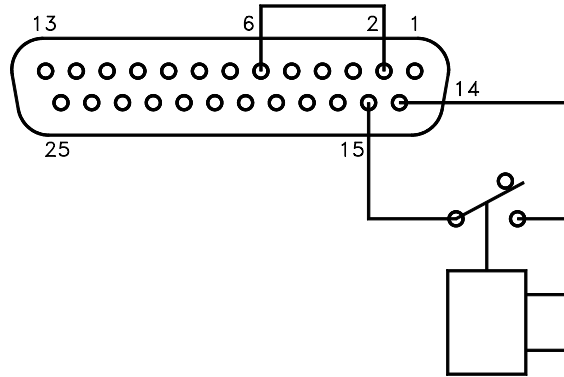

**Figure 4–13. Using Shutdown with Contact Closure of a Normally OPEN Relay (S1-6 Up)**

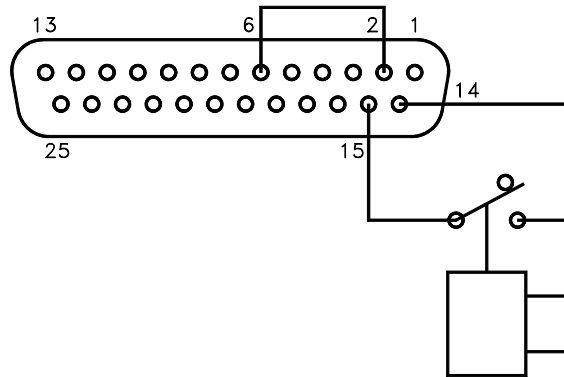

**Figure 4–14. Using Shutdown with Contact Closure of a Normally OPEN Relay (S1-6 Down)**

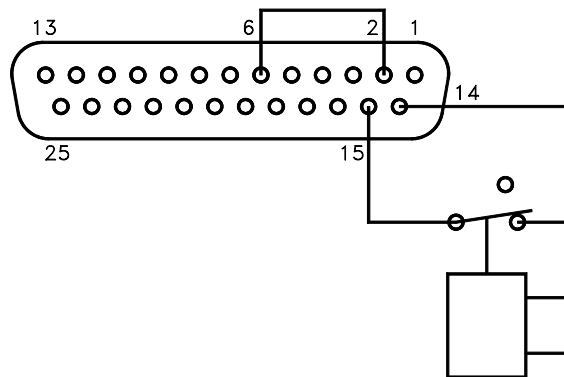

**Figure 4–15. Using Shutdown with Contact Closure of a Normally CLOSED Relay (S1-6 Up)**

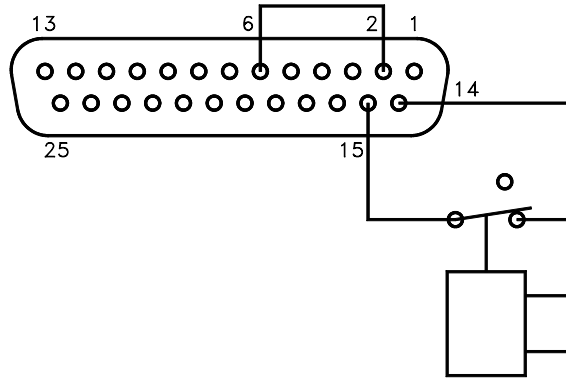

**Figure 4–16. Using Shutdown with Contact Closure of Normally CLOSED Relay (S1-6 Down)**

## 4.6 Remote Monitoring

### 4.6.1 Readback Signals

Calibrated readback signals for remote monitoring of the output voltage and current are available via connections at the J3 connector on the rear panel. Rear panel DIP switch S1 settings allow you to select either a 0–5 VDC or a 0–10 VDC range for the output. See *Section 4.2 Configuring for Remote Programming, Sensing, and Monitoring* for more information about making these connections.

The following table shows the required pin connections and switch settings for remote monitoring of readback signals with 0–5 VDC or 0–10 VDC outputs. Use shielded–twisted pair wiring (20 to 24 AWG) and ground the shield to J3 connector pin 6 or to the chassis via one of the J3 connector screws. The readback signal represents 0 to 100% of the model–rated output.

Readback Signal	J3 Connections		Switch S1 Settings		Output Signal: Range
	Signal (+)	Return (-)	Switch #	Setting	
Voltage Monitor	Pin 19	Pin 12	S1–4	UP	0–5 VDC
				DOWN	0–10 VDC
Current Monitor	Pin 7	Pin 12	S1–5	UP	0–5 VDC
				DOWN	0–10 VDC



**CAUTION!**  
Always remove J3 mating connector from supply before soldering.

## 4.6.2 Status Indicators

Status indicators for thermal shutdown, OVP circuit, programming mode, and operating mode are available via connections on the J3 connector on the rear panel.

The following table shows the indicator signals, the J3 connector pin at which they are available, an approximation of the signal magnitude, and the source impedance through which the signal is fed. Use 20 to 24 AWG wiring.

Indicator Signal / Alternate State	J3 Connections		Signal Voltage	Source Impedance
	Signal (+)	Return (-)		
Overtemperature Shutdown / Normal Operation	Pin 18	Pin 6	+5V	1k ohms
	Pin 18	Pin 6	0V	1k ohms
OVP Circuit Activated / OVP Circuit Not Activated	Pin 17	Pin 6	+5V	1k ohms
	Pin 17	Pin 6	0V	1k ohms
Remote Programming Mode / Local Programming Mode	Pin 4	Pin 6	+5V	1k ohms
	Pin 4	Pin 6	0V	1k ohms
Voltage Mode Operation / Current Mode Operation	Pin 5	Pin 6	+5V	1k ohms
	Pin 5	Pin 6	0V	1k ohms

## 4.7 Using Multiple Supplies

DLM-E Series power supplies of the SAME MODEL may be operated with outputs in series or in parallel to obtain increased load voltage or increased current. Split supply operation allows two positive or a positive and a negative output to be obtained. The power supply output may be biased up to a maximum of 150 VDC with respect to the chassis.



### WARNING!

**Use extreme caution when biasing the output relative to the chassis due to potentially high voltage levels at the output and J3 terminals.**

Do not attempt to bias program/monitor signal lines on the J3 connector relative to the power supplies positive output. The signal returns on the J3 program/monitor connector are at the same potential as the power supply return bus bar in a standard unit. Using the Isolated Programming Interface option allows control from a programming source biased relative to the supply's output. Contact factory for additional details.

### 4.7.1 Configuring Multiple Supplies for Series Operation

Series operation will obtain a higher voltage from a single output using two or more supplies. Connect the negative (-) output terminal of one supply to the positive (+) output terminal of the next supply. See Figure 4-17. The total voltage available is the sum of the maximum voltages of each supply (add voltmeter readings). The maximum allowable current for a series string of power supplies is the model rated output current of a single supply in the string.

**Note:** *The maximum allowable sum of the output voltages is 300 VDC. This is limited by the voltage rating of certain internal components. See Section 1 for maximum voltage rating.*

**CAUTION!**

Remote sensing must not be used during series operation.

**CAUTION!**

The remote programming input is internally referenced to the supply's negative output. Do not connect any remote programming input lines on the J3 connector to the supply's positive output.

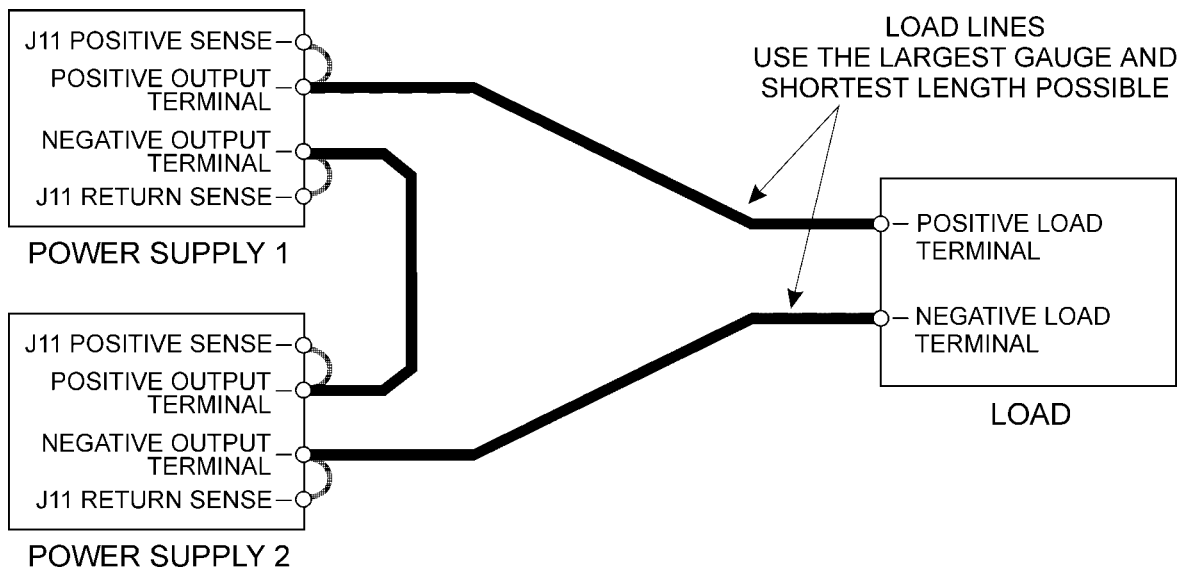

**Figure 4–17. Series Operation of Multiple Supplies**  
(Local sense lines shown are default J11 to busbar connections)

#### 4.7.2 Configuring Multiple Supplies for Split Supply Operation

Split supply operation uses two power supplies to obtain two positive voltages with a common ground, or to obtain a positive–negative supply.

To obtain **two positive voltages**, connect the negative output terminals of both supplies together. The positive output terminals will provide the required voltages with respect to the common connection. See Figure 4–18.

To obtain a **positive–negative supply**, connect the negative output terminal of one supply to the positive output terminal of the second supply. The positive output terminal of the first supply then provides a positive voltage relative to the common connection while the negative output terminal of the second supply provides a negative voltage. The current limits can be set independently. The maximum current available in split supply operation is equal to the model-rated output of the supplies used. See Figure 4–19.



**CAUTION!**  
**To prevent possible damage to the supply, do not connect the remote program return line of the negative supply to the common connection.**

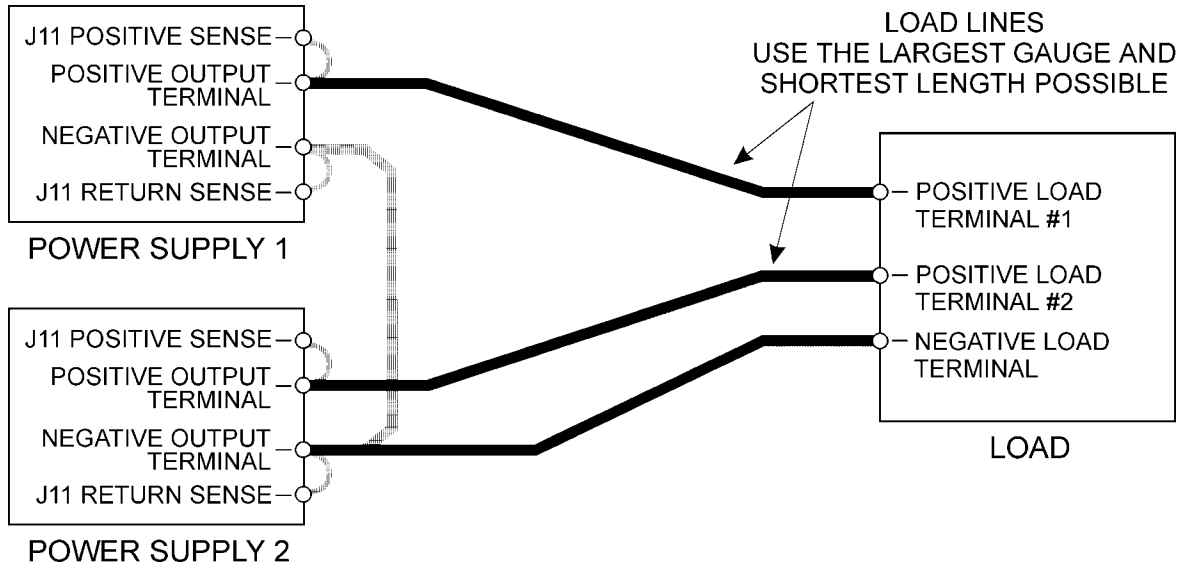

**Figure 4–18. Split Supply Operation of Multiple Supplies (Two Positive Voltages)**  
 (Local sense lines shown are from J11 to busbars)

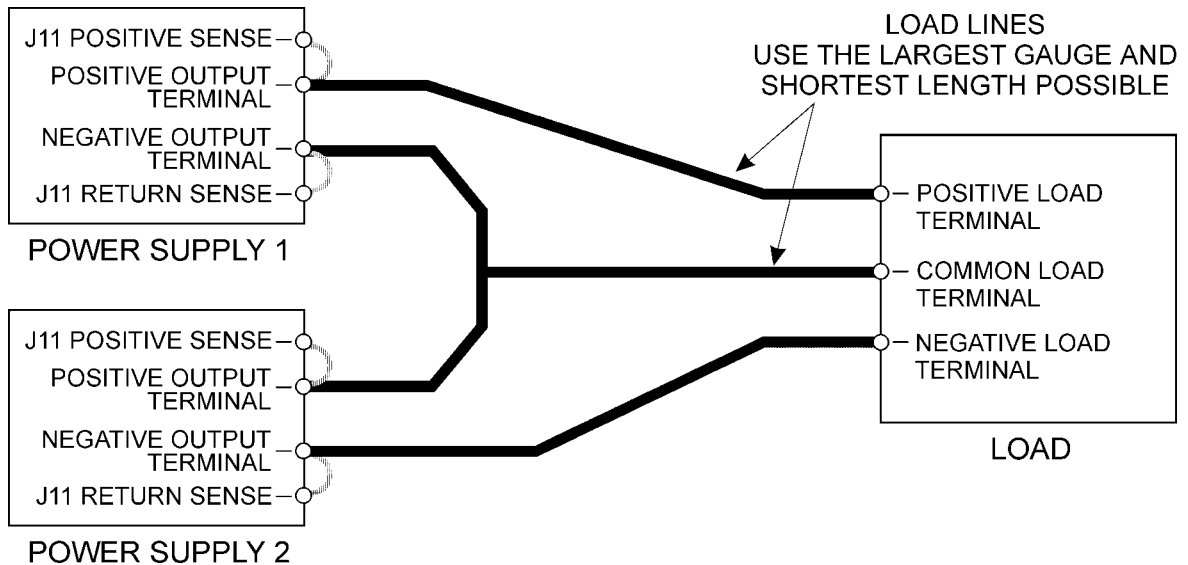

**Figure 4–19. Split Supply Operation of Multiple Supplies (Positive–Negative Supply)**  
 (Local sense lines shown are from J11 to busbars)

### 4.7.3 Configuring Multiple Supplies for Parallel Operation

Parallel operation is used to obtain a higher current output supply using up to five units. The DLM-E supplies are designed to be easily paralleled with current sharing between units with the use of a simple cable between supplies. See Figure 4-20.

#### Notes:

1. Set the rear panel switch S1-7 down on the Slave unit(s) only. This allows for full control of the output voltage, current, and OVP trip level through one Master supply.
2. To control the slaves, plug the Master/Slave cable into J12 of the Master supply and into J13 of the first Slave supply.
3. Plug an identical cable into J12 on this slave and connect to J13 on any subsequent Slave supplies as required until all supplies in the Master/Slave set have a cable plugged into either J12 or J13 or both.
4. Ensure that all of the outputs of the positive terminals (+) and negative terminals (-) are also connected in parallel. Refer to Section 2.8 for a discussion on the proper method for connecting to the load.
5. The total current available is the sum of the maximum currents of each supply. Each supply will read back the portion of current that it is supplying to the load and these must be added together to get the total load current.



#### CAUTION!

To prevent internal damage, ensure that the Master/Slave Parallel Output Enable switch S1-7 is Up on the Master supply and Down on all Slaves. There can be only one Master supply!

Pin Number	Function	Voltage Level
1	Parallel OVP Control	0-5 V
2	Parallel Current Command	0-7V
3	Parallel Command Return (-)	0V
4	Parallel Voltage Control	0-5V
5	Parallel Output Command	5V
6	Programming/Monitor Return (-)	0V

**Table 4-3. J12, J13 Connectors-Parallel Port Function and Pinout**

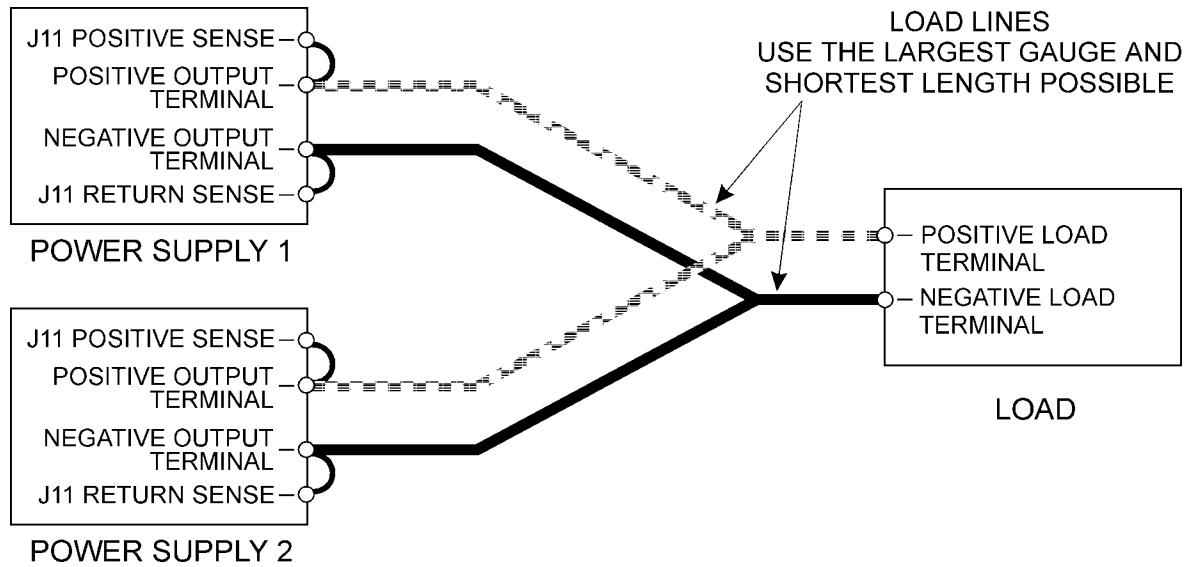

**Figure 4–20. Parallel Operation of Multiple Supplies**  
(Local sense lines shown are from J11 to busbars)

## 4.8 Front Panel Lockout

The front panel lockout mode enables a user to disable the front panel controls when the unit is being programmed exclusively through the J3 remote input connector. To activate the front panel lockouts, push the front panel LOCAL/REMOTE switch to the REMOTE position with the S1 rear panel Dip switch S1–8 in the down or closed position. Once the lock function has been activated, it disables local control for all output control functions, except the AC power switch, which remains under front panel control and lights the front panel LOCK LED.

# SECTION 5

## MAINTENANCE AND TROUBLESHOOTING

### 5.1 Periodic Service

This section provides periodic maintenance, calibration and troubleshooting information.

Except for periodic cleaning and calibration, no routine service is required. Whenever a unit is removed from service, it should be cleaned, using denatured or isopropyl alcohol or an equivalent solvent on the metal surfaces, and a weak solution of soap and water for the front panel. Low pressure compressed air may be used to blow dust from in and around components on the printed circuit boards.

### 5.2 Troubleshooting

Units requiring repair during their warranty period should be returned to Sorensen for service. Unauthorized repairs performed by anyone other than Sorensen Company during the warranty period may void the warranty. Any question regarding repair should be directed to the Service Department, Sorensen Company, Division of Elgar Electronics Corporation, 1-800-458-4258.



#### **CAUTION!**

**Potentially lethal voltage exists in the power circuit and the output of high voltage models. Filter capacitors store potentially dangerous energy for some time after power is removed. Only experienced technical personnel should make repairs. Be sure to isolate the power supply from the input line with an isolation transformer when using grounded test equipment such as an oscilloscope in the power circuit.**

#### 5.2.1 Preliminary Checks

If the power supply displays any unusual or erratic shut the power supply off immediately and disconnect it from the AC power source. Check all loads, programming and monitoring connections and circuits. Check the AC input for correct voltage and frequency. Correct any problems found and retest the system. If no problems are found or the unit fails to operate correctly upon re-testing proceed with internal troubleshooting as described below.

## 5.2.2 Troubleshooting at the Operation Level

Use the checks in Table 5–1 to ensure the DLM–E Series power supply is configured and connected for default operation at the front panel. If you need any further troubleshooting, call customer service.

Symptom	Check	Further Checks and Corrections
No output and the display is blank	Is input voltage within specified range?	Connect to appropriate voltage source. See <b>Section 2.6</b> .
	Power switch ON?	Turn on power.
	Internal circuit?	See your service technician.
No output but the display lights	OVP LED lit?	See <b>Section 2.4.1</b> .
	Front panel S/D LED lit?	See <b>Section 2.4.1</b> .
	OTEMP LED lit?	See <b>Section 2.4.1</b> .
	Current limit set to zero?	See <b>Section 3.2.2</b> .
	Voltage control set to zero?	See <b>Section 3.2.2</b> .
	REM LED lit?	See <b>Section 4.3</b> .
	Is front panel ON LED lit?	Connect unit to AC supply in specified range. See <b>Section 2.4.1</b> .
Internal circuit.	See your service technician.	
Output not adjustable	Is unit in current limit mode? (Green Current Mode LED lit.)	Turn current knob clockwise to increase current limit. Reduce load if current is at maximum. See <b>Section 3.2.1</b> .
	Is unit in REMOTE mode? (Green REM LED lit.)	See <b>Section 4.3</b> .
	Is unit in LOCK mode? (Green LOCK LED lit.)	See <b>Section 4.8</b> .
	Is unit at maximum voltage or current limit?	Reduce load for lower voltage or current requirement.
Output voltage fluctuating or regulation poor	Is unit at current limit?	Increase current limit setting or reduce load. See <b>Section 3.2.1</b> .
	Is input voltage within specified range?	Connect to appropriate AC voltage source. See <b>Section 2.6</b> .
	Are sense lines connected?	See <b>Section 2.8</b> and <b>Section 3.3</b> .
	Is unit under remote analog control?	Ensure program source is stable.
	Internal circuit.	See your service technician.
Output oscillating	Internal circuit.	See your service technician.

**Table 5–1. User Diagnostics**

### 5.3 Calibration

Calibration of the output voltage, current, or OVP is accomplished using multiturn trim pots. Table 5–2 gives the location, function, and effect of each potentiometer.

Calibration is performed at the factory during testing. Recalibration should be performed annually and following major repairs. With the cover in place, calibration should be done through access holes in the cover or front panel. See Figure 5–1.

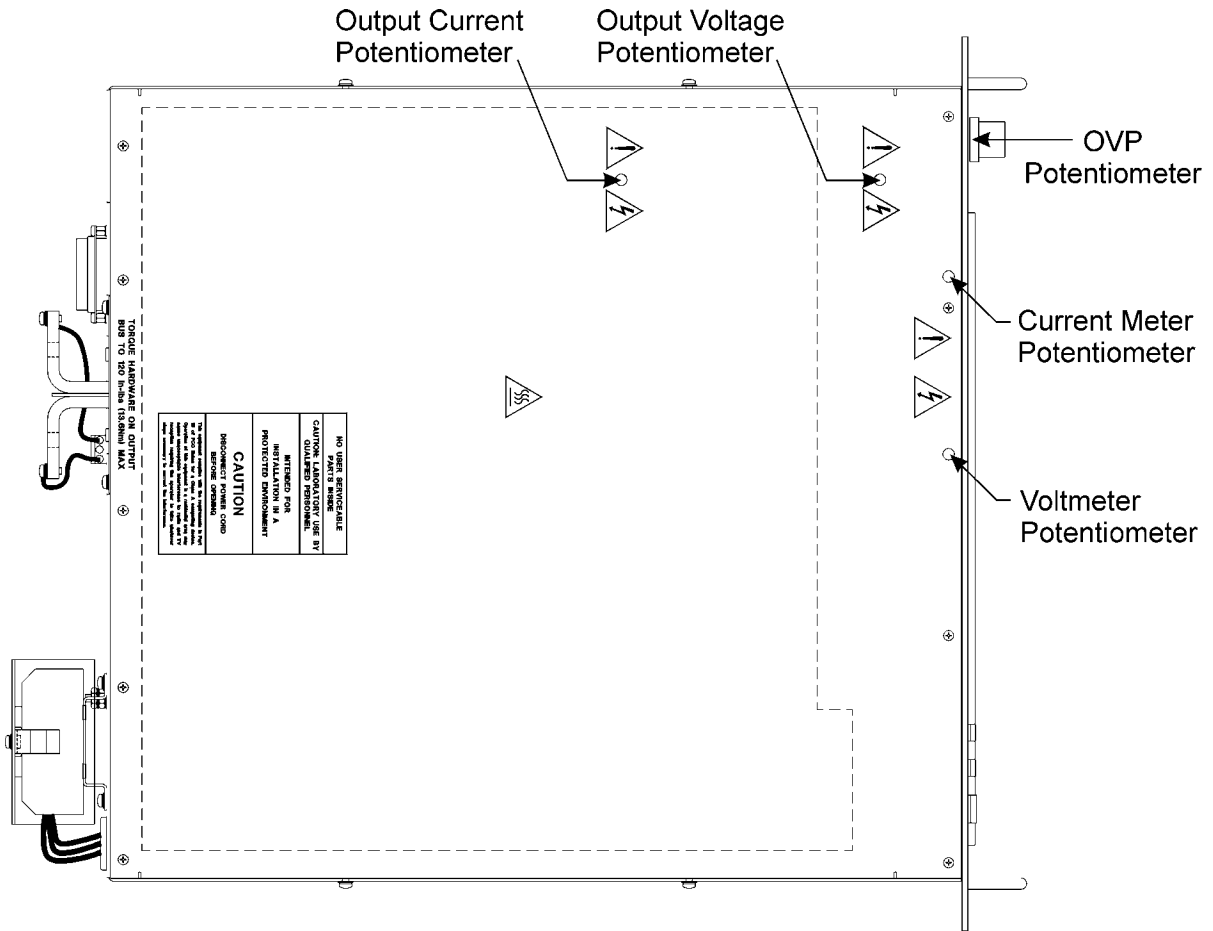

**Figure 5–1. Potentiometer Locations**

Location	Function	Adjustment Procedure
Top Cover	Output Voltage	Clockwise rotation increases output voltage setting
Top Cover	Output Current	Clockwise rotation increases output current setting
Top Cover	Front Panel Voltmeter	Clockwise rotation increases voltage meter reading
Top Cover	Front Panel Current Meter	Clockwise rotation increases current meter reading
Front Panel	OVP	Clockwise rotation increases OVP shutdown setting

**Table 5–2. Potentiometer Adjustment Procedures**

## 5.4 Ordering Parts

Do not substitute parts without first checking with Sorensen's Service Department. Parts may be ordered from the factory with the information below. Order parts from:

SORENSEN  
 Sales & Technical Support  
 9250 Brown Deer Road  
 San Diego, CA 92121-2294  
 1-800-525-2024  
 Tel: (858) 450-0085  
 Fax: (858) 458-0267  
 E-mail: sales@sorensen.com  
 www.sorensen.com

**Note:** *When ordering parts please include the model number and serial number of the unit with your order.*

## 5.5 Fuse Ratings

Table 5–3 provides a listing of Fuse Ratings.

Reference Designator	Fuse Type	Rating	Size	Option
F1, 2, 3 (Rear Panel)	Fast Acting, AC	F, 25A, 600V	13/32" x 1½	Std
F1, 2, 3 (Rear Panel)	Fast Acting, AC	F, 10A, 600V	13/32" x 1½	M1
F1, 2, 3 (Rear Panel)	Fast Acting, AC	F, 8A, 600V	13/32" x 1½	M2
F1 (Inside Chassis)	Fast Acting, DC	F, 15A, 600V	13/32" x 1½	—
F5, 6	Slow Blow, AC	2A, 250V	5 x 20 mm Leaded	—
F7	Fast Acting, DC	0.5A, 125V	PCB	—

**Table 5–3. Fuse Ratings**